

Service Dept  
Copy

**TAC/SCAN™**



**SEGA®**

Owner's Manual  
Manual Part No. 420-0795

SERVICE DEPT  
COPY



## Owner's Manual

Manufactured By

**SEGA**<sup>®</sup>

TLX 910-335-1621

**TAC/SCAN OWNER'S MANUAL**

**Copyright © 1982 by SEGA/Gremlin, All Rights Reserved**

## TABLE OF CONTENTS

Introduction . . . . .	1
Game Concept . . . . .	2
Scoring . . . . .	4
Game Set-Up and Inspection . . . . .	5
Specifications and Important Notes . . . . .	6
Option Selection . . . . .	8
Self-Test . . . . .	11
G-80 Bus Details . . . . .	15
Troubleshooting Procedures . . . . .	16
Circuit Description . . . . .	20
Monitor Block Diagram . . . . .	25
Adjustments and Specifications . . . . .	36
Parts Catalog . . . . .	40
Schematics . . . . .	114

## INTRODUCTION

TAC/SCAN is a microprocessor based coin-operated electronic game, that makes extensive use of digital integrated circuitry and television monitor concepts. This manual is designed for the use of the maintenance technicians who possess a general working knowledge of solid-state circuitry and video monitor theory. Any individual NOT knowledgeable in these areas SHOULD NOT attempt repair of the electronic portions of the game.

In addition to this manual and training in electronics, troubleshooting and repair will be facilitated by: access to general electronic type handtools, a multimeter, a 50 to 100 Mhz oscilloscope and a logic probe would be helpful.

Technical assistance is available by calling (800) 854-1938, or (800) 722-8576 inside CA. Questions or comments concerning TAC/SCAN or any of our games are welcome and should be directed to:

Customer Service Manager  
SEGA/Gremlin  
16250 Technology Drive  
San Diego, California 92127

## GAME CONCEPT

TAC/SCAN is a one or two player alternate action game, displayed via SEGA's Color X-Y video system. Commanding unprecedented firepower, the player maneuvers seven fighter ships in a squadron formation. All seven ships fire at once when the FIRE button is pressed, producing a spectacular missile salvo.

The object of the game is to accumulate points by destroying incoming enemy ships while dodging fireballs launched by these enemies. TAC/SCAN presents the space battle from two entirely different perspective views in the course of the game, with visually exciting transition sequences interconnecting the two views.

The player begins the game with a seven ship formation, and a supply of reserve ships which are shown above the player score on the screen. The number of reserve ships at the beginning of the game are switch selectable. An ADD SHIP button placed next to the FIRE button transfers one of the reserve ships in the squadron formation. Where the reserve ships are placed is shown by a half-intensity fighter in the formation. This "add ship" position continuously cycles between the empty squadron positions, and the advanced player will time the ADD SHIP function to place squadron fighters at preferred positions.

A player fighter is blown up by contact with either an enemy ship or an enemy fireball. Whenever all seven ship positions become empty the game is over, EVEN IF THERE ARE REMAINING RESERVE FIGHTERS shown above the player score. Thus the player must continuously judge when to add reserve fighters by using the ADD SHIP button. Add them too early, and they might be depleted too fast; use them too late and you risk ending the game with reserve fighters left over.

There is an additional way to add ships to the squadron. During the course of the action, player fighter ships enter the playfield and intermix with the enemy ships. The player can capture these fighters directly into the seven ship formation by steering them into empty fighter positions. The player's missile fire DOES NOT blow up friendly fighters--only enemy ships.

TAC/SCAN begins with a top view of the battle. For the first ten seconds the player shoots at enemy ships without having to worry about return fire. After this "warm-up" period, game play escalates dramatically. During this first phase, a different type of enemy appears just after

two of the player fighters fly onto the screen. This is the Stinger, which flits around the field and shoots a deadly laser. This ship is a high-priority target, since if not dealt with, it will pick off all of the squadron ships and end the game.

When the player attempts to dock a friendly fighter into the squadron formation, he or she has the choice of any of the empty ship positions shown in the squadron. A special feature occurs when the player ship docks into the frontmost ship position (marked with a red "cursor"). This causes the squadron formation to regroup into a different pattern. If the lead position is occupied, a fighter is added to the reserve count above the player's score.

At the end of the first phase (the top view) the squadron ships regroup, and a dramatic transition sequence takes the player into phase two. This sequence consists of the fighters rising and enlarging in size, then turning INTO the screen, lighting afterburners, and proceeding to fly forward to continue the battle. The enemy ships now appear far off in the distance, and grow in size as they approach the player's squadron. The player is given chances to rendezvous with friendly fighters, as in phase one.

At the end of this second phase, a space tunnel appears on the screen, and the player uses the rotary control to steer the squadron formation through the tunnel. Any fighter which hits a side wall of the tunnel explodes on contact. A triangular guide is shown during this sequence to show the player where his triangular ship formation should be. If the player keeps the formation centered within the guide, no ships will be lost.

Once out of the space tunnel, the player resumes with the second round. This is a more difficult top view battle, as at the beginning of the game. TAC/SCAN proceeds with multiple two phase rounds (phase one is the top view, phase two is the rear view) until all squadron ships are lost.

A switch option allows bonus reserve ships to be added with certain score values. The factory set option is to add one reserve ship every 30,000 points.

Regardless of the number of squadron ships on the screen, there are always seven missiles at a time available to the player. If there are seven ships on the screen (a full squadron), pressing the FIRE button launches all seven at once. Another push of the FIRE button cancels the

seven in flight and launches seven new ones. If the squadron is not full, the seven missiles can be independently targeted. For example, with a single ship, seven missiles can be fired in seven directions, and only when the eighth is shot is the first one terminated (if it is still on the screen).

The two player game is played with players alternating after successful negotiation of the space tunnel. Whenever a player is eliminated, the other player continues and finishes the game.

#### SCORING

	<u>Enemy Ships</u>	<u>Stinger</u>
Round 1	100 points	1000 points
Round 2	200	2000
Round 3	300	3000
Round 4	400	4000
Round 5	500	5000
Round 6	600	6000
Round 7	700	7000
Round 8 and above	800	8000

Destroying two enemy ships with a single missile salvo doubles the point values shown.

Destroying three enemy ships with a single missile salvo triples the point values shown.

## GAME SET-UP AND INSPECTION

### 1. Inspection

- a) Before plugging in your new game, inspect it closely to spot any possible shipping damage. Check to ensure the graphics are in place, the monitor is not damaged and that the overall cabinet is in good condition.
  
- b) Open the coin mechanism door and inspect the inside of the game electronics compartment. Be sure no components or connectors have come loose. Proper connector fittings must be checked before game power is applied. Check all related connectors for good contact. Although disconnected connectors are easily spotted, poor contacts are difficult to locate. The connectors should therefore be pushed in firmly and then loosened to spot poor connections.
  
- c) Check to ensure the fuses are intact. There are five fuses (not counting the monitor fuses which are detailed in the monitor manual for this game). One fuse is located on the AC junction box. The other four are on the power supply PC board.

### 2. Voltage Selection

Before plugging in your game, make sure that the game voltage is correct for your location. Locate the two leads from the AC junction box to the power transformer. For 110 VAC, they should be connected to terminals 1 and 3 on the power transformer. For 100 VAC, connect 1 and 2, and for 220 VAC applications, they should be connected to 1 and 4. You will also notice on the AC junction box that there is a safety interlock switch. When the front panel is in place the switch is depressed and the game receives power. Removing the front panel, the switch returns to its original position and the power is cut off from the game. For servicing, this switch can be pulled out and power will be restored.

### 3. Game Specifications

Power                    100 VAC, 60HZ (nominal), 150 watts maximum



### 3. Game Specifications (Cont)

Power	110 VAC, 60HZ (nominal), 150 watts maximum 220 VAC, 60HZ (nominal), 150 watts maximum
Dimensions	25-1/2 inches wide X 30-1/4 inches depth (64.8 cm wide X 76.8 cm depth) 72-1/2 inches height (184.2 cm height)

### 4. Important Notes

a) The following note is included in compliance with FCC rules:

WARNING: This equipment generates, uses, and can radiate radio frequency energy and if not installed and used in accordance with the instruction manual, may cause interference to radio communications. As temporarily permitted by regulations, it has not been tested for compliance with the limits for Class A computing devices pursuant to Subpart J of Part 15 FCC Rules, which are designed to provide reasonable protection against interference in which case the user at his own expense will be required to take whatever measures may be required to correct the interference.

b) Miscellaneous

NEVER remove circuit board connections while power is on.

NEVER replace any components with anything other than exact replacement parts.

DO NOT replace fuses with anything other than proper value. A blown fuse indicates an overload condition within the game. Replacing the fuse with a higher value can cause damage to internal components, if an overload occurs.

### 5. Control Panel Removal

With the door to the game electronics compartment open, disconnect the control panel harness, reach under the control panel and flip the fasteners on

both sides of the control panel. The control panel will now swing outwards. Slide the spring-loaded pins on both sides and remove the control panel.

#### 6. Front Plexiglass, Interior Graphics and Graphics Frame Removal

The front plexiglass, which secures the interior graphics, is held in place by the control panel. Release the fasteners on the control panel and swing it down. Directly under the front plexiglass, you will notice a small frame support piece. Grab it by the hand slot in the middle and pull it from the game. The front plexiglass can now be removed easily by lifting it on the bottom slightly and pulling it outward. The interior graphics can now be removed. You will also see the graphics frame, which is located directly behind the interior graphics. It must be removed when taking out the monitor. To remove the graphics frame, simply grip two sides and carefully lift out.

#### 7. Card Cage Removal

If it is necessary to remove the card cage for servicing, first disconnect all the connectors. Then remove the three mounting screws, located on the front bracket. The card cage can now be slipped from under the rear bracket and removed from the game.

#### 8. Logo Panel Removal

Underneath the logo panel are four mounting screws. Remove these and the logo panel can be lifted from its slot. With the logo panel removed, easy access is gained to the speaker and fluorescent lamp assemblies for servicing.

#### 9. Monitor Removal

To remove the monitor for servicing or replacement, first open the rear panel on the cabinet and disconnect the power cable and video cable to the monitor. Then, remove the front plexiglass, interior graphics and graphics frame as explained earlier. Remove the four bolts in each corner of the monitor board. Now grasp the board by the hand holds provided at top and bottom and pull the monitor from the front of the cabinet.

OPTION SELECTION

<u>OPTION</u>	<u>SWITCH #1</u>							
	1	2	3	4	5	6	7	8
UPRIGHT	X	X	X	X	X	X	X	0
COCKTAIL	X	X	X	X	X	X	X	C
8 EXTRA SHIPS	X	X	X	X	0	0	X	X
6 EXTRA SHIPS	X	X	X	X	0	C	X	X
4 EXTRA SHIPS	X	X	X	X	C	0	X	X
2 EXTRA SHIPS	X	X	X	X	C	C	X	X
GAME DIFFICULTY: HARD	X	X	0	0	X	X	X	X
MEDIUM	X	X	C	0	X	X	X	X
EASY	X	X	C	C	X	X	X	X
BONUS SHIP: 10,000 POINTS	0	0	X	X	X	X	X	X
20,000 POINTS	0	C	X	X	X	X	X	X
30,000 POINTS	C	0	X	X	X	X	X	X
NO BONUS SHIP	C	C	X	X	X	X	X	X
<u>OPTION</u>	<u>SWITCH #2</u>							
	1	2	3	4	5	6	7	8
4 COIN/1 CREDIT	C	C	C	C	C	C	C	C
3 COIN/1 CREDIT	C	C	C	0	C	C	C	0
2 COIN/1 CREDIT	C	C	0	C	C	C	0	C
1 COIN/1 CREDIT	C	C	0	0	C	C	0	0
1 COIN/2 CREDIT	C	0	C	C	C	0	C	C
1 COIN/3 CREDIT	C	0	C	0	C	0	C	0
1 COIN/4 CREDIT	C	0	0	C	C	0	0	C
1 COIN/5 CREDIT	C	0	0	0	C	0	0	0

OPTION SWITCH SETTINGS - (cont.)

<u>OPTION</u>	<u>SWITCH #2</u>							
	1	2	3	4	5	6	7	8
1 COIN/6 CREDIT	0	C	C	C	0	C	C	C
2 COIN/1 CREDIT	0	C	C	0	0	C	C	0
4 COIN/2 CREDIT								
5 COIN/3 CREDIT								
2 COIN/1 CREDIT	0	C	0	C	0	C	0	C
4 COIN/3 CREDIT								
1 COIN/1 CREDIT	0	C	0	0	0	C	0	0
2 COIN/2 CREDIT								
3 COIN/3 CREDIT								
4 COIN/4 CREDIT	0	C	0	0	0	C	0	0
5 COIN/6 CREDIT								
1 COIN/1 CREDIT	0	0	C	C	0	0	C	C
2 COIN/2 CREDIT								
3 COIN/3 CREDIT								
4 COIN/5 CREDIT								
1 COIN/1 CREDIT	0	0	C	0	0	0	C	0
2 COIN/3 CREDIT								
1 COIN/2 CREDIT	0	0	0	C	0	0	0	C
2 COIN/4 CREDIT								
3 COIN/6 CREDIT								
4 COIN/8 CREDIT								
5 COIN/11 CREDIT								

OPTION SWITCH SETTINGS - (cont.)

<u>OPTION</u>	<u>SWITCH #2</u>							
	1	2	3	4	5	6	7	8
1 COIN/2 CREDIT	0	0	0	0	0	0	0	0
2 COIN/4 CREDIT								
3 COIN/6 CREDIT								
4 COIN/9 CREDIT								

X = NOT USED                      0 = OPEN                      C = CLOSED

## SELF-TEST

The G-80 system contains a built-in self-test system, activated by depressing the red self-test switch located on the CPU Board. If the cover to the G-80 card cage is in place, the switch can be activated by putting a pen or pencil through the hole provided on the cover.

### Basic diagnostics test sequence:

1. CPU RAM
2. Maskable interrupts
3. First 1K of game ROMs
4. Video RAM and Hardware multiplier
5. Player start buttons
6. Display screen (visual)
7. All game ROMs
8. System inputs
9. Game controls
10. Sounds/Voice

### Individualized diagnostics descriptions and procedures:

1. CPU RAM - tests all RAM on CPU card before proceeding, system needs to use this RAM for stack and variables during other tests so if any locations are bad processor will halt (halt light will come on).

2. Maskable interrupts - video interrupt is enabled through output port bit and all maskable interrupts are enabled inside processor, CPU then executes several HALT instructions to insure that at least one edge triggered interrupt has occurred. If no interrupts occur during this test the halt light will remain on constantly. This is the same result as a bad CPU RAM. This ambiguity can be eliminated by checking the vertical interrupt another way. The system reset/power-up logic will also halt if the video interrupt is not functioning, to try this press the RESET switch.

3. First 1K of game ROMs - the first 1K of the first game ROM will be checked for validity. If this portion of the first ROM is bad the system will not be able to proceed because vital information defining parameters of the game are stored in this first 1K. If an error occurs during this validity check, the CPU will lock up and repeatedly flash the halt light.

4. Video RAM and Hardware multiplier - the video RAM is tested first and in the event that it tests good then the hardware multiplier is checked. If the video RAM is good, the message "ALL VIDEO RAM GOOD, MULTIPLIER GOOD" appears. If a bad video RAM chip is found, then the message "BAD VIDEO RAM, CHIP U##" appears on the screen along with that chip's location. Due to the fact that sometimes a bad video chip causes the display to be erratic, the system also flashes out the bad chip's location on the halt light, over and over again separating the U#s with a one second on pulse.

The hardware multiplier is used in the game to multiply two 8 bit numbers together to form one 16 bit product. This test performs a select group of multiplications, over 2,000 multiplications in actuality, designed to thoroughly exercise the process of multiplication between the software and the hardware multiplier. The messages "GOOD" or "BAD" are the only indication of functionality with respect to this test.

5. Player start buttons - one of the two "game start" push buttons on the front of the cabinet is very special. The "one player start" button was designated by the system as a way to terminate the test that is currently being run. The reason that these two buttons were tested relatively early in the sequence, was so that the remaining tests could use the "one player start"

button for a termination signal. To be sure that these two buttons are functioning properly, see that when untouched the status indicated is "0" (for open switch contact) and that when pushed or depressed momentarily the indicated status is "C" (for closed switch contact) during the time the button is down. This notation for switches being in the open or closed state, "0" or "C", will be used throughout the diagnostic sequence whenever the status of a switch is being displayed on the screen.

6. Screen - this test is supplied by the game logic, external to the CPU ROM, to provide a visual indication of how well the display screen is functioning. It tests beam deflection and colors to check that all electron guns are functioning. In the display, you should see some sort of test showing the colors white, red, green and blue.

7. All game ROMs - the intent of this test was to insure the integrity of all of the data in all of the game ROMs. At the time the ROMs for a game were originally generated there was an algorithm performed on each 1K block of data. Each of these calculations, a form of CRC (cyclic redundancy check, similar to a checksum), produced one 16-bit word. These words are stored, along with a Gremlin part number, in the first ROM. When this test is run, all of these 16-bit CRC words are regenerated and are compared to the known values stored in the table in the first ROM. If one of these newly calculated values does not match its corresponding stored value, then the system kicks out an error which amounts to the message "BAD ROM" followed by one or more bad part numbers of that ROM that was found in mis-match. If all ROMs are good the screen displays: "ALL ROMS GOOD". Then the system quickly proceeds on to the next test.

8. System inputs - these inputs are referred to as 'system inputs', simply because they control system functions, such as credit accumulation, coinage options, game configuration, etc. The diagnostic user may check to see that the coin switches, service switch, and option dip switches are functioning properly. The open and closed switch notation applies here as described earlier.



9. Game controls - the names of the controls that the game player would use to control the action on the screen is what this test was designed to check. Make sure that when hands are off of the controls all of the switches are open. When a particular control is twisted, pushed, turned or in whatever way activated, watch to see that the status of that control, and only that particular control, changes to reflect the action on the control panel. The screen should display from open to closed.

10. Sounds/Voice - just sit back, listen and watch this one. All of the sounds made by the game will be produced and their respective names will appear in the center of the screen. The termination button acts sluggish during this test due to the fact that some of the sounds must be created by subroutines external to the CPU ROM. After completion of this test, the system will return to the advertising mode.

# G-80 Bus Detail

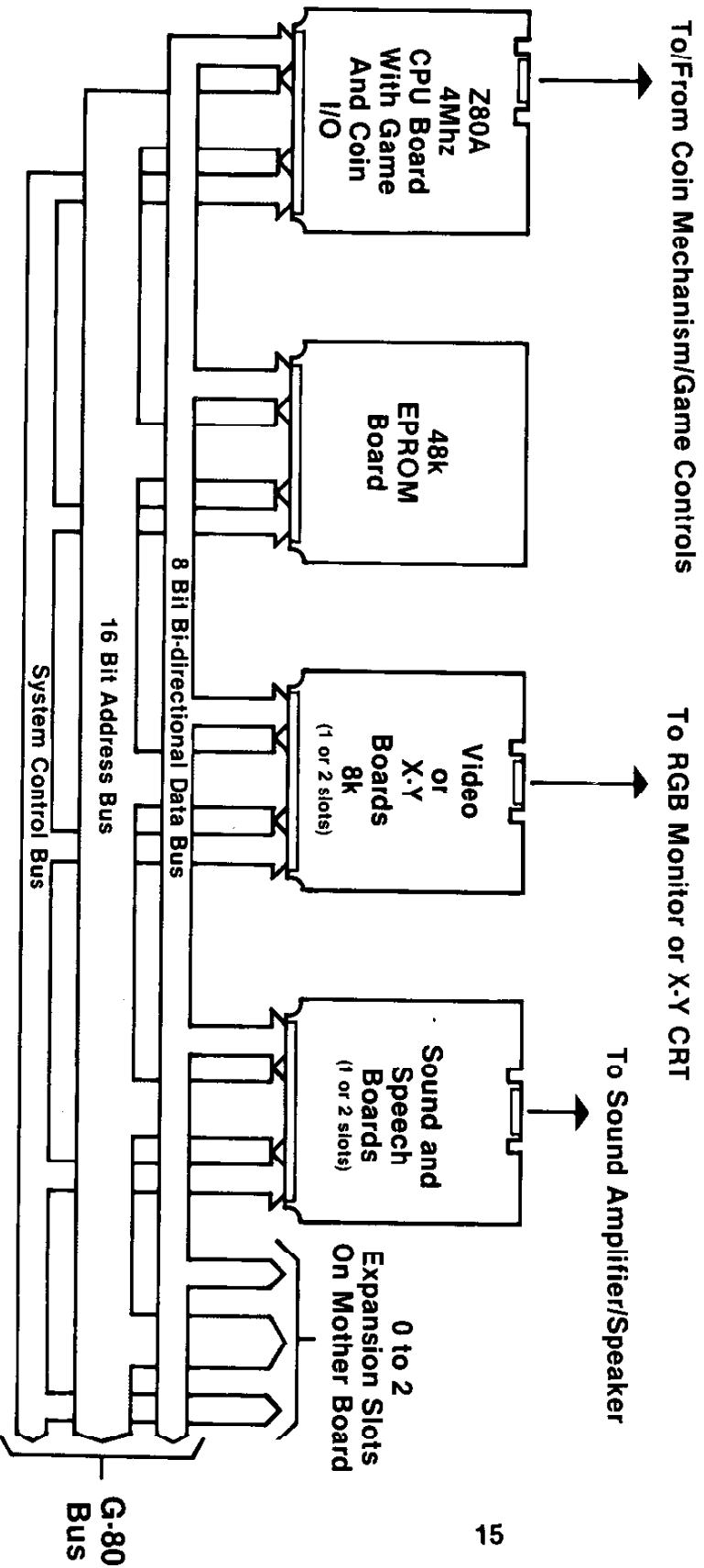

## TAC/SCAN TROUBLESHOOTING PROCEDURES

TAC/SCAN is a "state-of-the-art" electronic microprocessor based, video game. The result of hundreds of hours of work, design, research, experiment and more work. However, as with any electronic device, component failure or other problems can result in a game that doesn't function properly, or doesn't function at all. In either case, your game is "down", and so critically, are your profits.

Your objective is to fix it as quickly as possible, and logical troubleshooting goes a long way toward that repair. Although many troubleshooting methods may be familiar to you, procedural logic is common among them, and might be stated in this order: visual inspection, symptom recognition, symptom isolation, function isolation, component isolation and repair. Familiarity with the equipment in question will allow you to bypass one or more of these steps, as any particular problem may be obvious to you, or may have happened before. In general though, these 6 steps form a good premise upon which to approach your "down" game.

An extremely important item in our procedure is the first mentioned, giving the gear the "once over". A large percentage of failures found in electronics, show themselves visually and often a great deal of time can be saved by inspecting for burnt or blown components, loose or disconnected wiring or connectors, or PCB traces burnt or pulled up. Thorough visual inspections become increasingly important the closer you get to the faulty item, and should be repeated each time another portion of the game is eliminated. Symptom recognition (as with all electronic troubleshooting) in your game depends first, on knowing what a proper display is, and second, knowing how your display differs from a normal one. Symptom isolation follows naturally; (i.e., "I have no picture", "I have no sound", "I have no control over the car", "the picture is scrambled"), ergo, a video, audio, input or logic problem. Function isolation, such as a sync problem with the video, requires that you consider those functions that go to make up video sync. Is it a monitor problem, or an "on-the-board" problem? A monitor input check to verify the signal will tell you. Does the board have the voltage (from the power supply) that it needs? Yes? We must have a board failure, as we've just isolated down to function.

Taking our sync problem further, before we begin our search for an individual component, let's reapply that first item in our "Logical Troubleshooting Procedure". Look at the board. Open resistors, diodes, and capacitors often give themselves away.

Noticing a trace literally burned open can save you serious "down-time". The board looks OK, so on we go. Specific component isolation relates to the specific nature of the failure, component commonality, proper inputting (both signal and power) and proper outputting (as in the case of an output held high, low, or floating by input port failure in the succeeding state). More general problems (such as a total loss of video sync) requires the more involved procedure of systematic elimination of possibilities. This operation can be expedited however, by dividing the circuit in half, establishing a "go-no/go" at that point, and again dividing the suspect circuit portion in half. The largest possible areas can be eliminated in this manner, dividing and subdividing until the individual component failure is found.

As we've outlined previously, any electronic repair procedure consists of a series of efforts to isolate a problem down to a "managable" level; restating our Logical Troubleshooting Procedure in 6 steps, 1. Visual Inspection, 2. Symptom Recognition, 3. Symptom Isolation, 4. Function Isolation, 5. Component Isolation, and 6. Repair.

In our TAC/SCAN game system, we are dealing with, essentially, 3 major functional components:

1. The Power Supply
2. The G-80 Boards (Card Cage Module)
3. The Color X-Y Monitor

So, in a typical maintenance procedure, having isolated down to Function (Step 4.), we would next attempt to determine which of the 3 major elements is defective. In the following paragraphs, we will look at each element and some of its sub-divisions as a guide in isolating further.

Usually, the power supply can be eliminated as the source of a problem if the games comes up on the screen. The major exception is when the game plays normally but no sounds are produced. In this case, the power supply's amplifier circuit should be checked for audio signals from the sound and speech boards. If they are present on the amplifier output, then a bad speaker or connection is probably the cause of the problem. If the signals are not there, suspect the amplifier circuits on the sound and/or speech boards.

If the picture does not appear on the screen, check the power supply for the main AC voltage to the primary of its transformer; then ensure that the G-80 boards are supplied with the correct DC voltages from the power supply. Also make sure the 3 VAC reset signal is being applied to the CPU board. If all these tests prove normal, then eliminate the power supply as cause of the problem and proceed to check the remaining functional game components - G-80 boards and monitor.

In most cases, a simple test will help to isolate a problem of no picture to either the G-80 boards or monitor. On an oscilloscope, look for varying voltage signals on pins 1 and 4 of the 4-pin Molex connector on the Timing Board. If the signals look similar to those shown in Figure 1, check for signals swinging between 0 and +4 volts on the RGB outputs (4-pin Molex connector pins 4, 1, 2 respectively) on the Control Board. If all three outputs are at 0 volts, suspect the X-Y boards. If the signals appear normal, suspect the monitor as the cause of the problem. If however, pin 1 (to the monitors horizontal input) is held at or near +4 or -4 volts DC, suspect one or both X-Y boards. If pin 4 (to the vertical input) is held at or near +3 or -3 volts, suspect the other G-80 boards. In either case, TURN OFF THE POWER AND IMMEDIATELY DISCONNECT THE X-Y MONITOR. Proceed to check the inputs to D/A converters U1 and U4 (T5) for active signals. Verify that none of the Character Data lines (CDO-CD7) are pulled high or low, or are floating. Check for the XCL and YCL clock signals from U28 (T6). Verify that the 15 MHz crystal clock is operating and that a 40 Hz signal is present on pin-11 of U13 (T7). Check BOS signal to be sure it is not held; signal DRAW should be switching high and low. On the Control Board, observe the signal FETCH to ensure it pulses high and low. Also, none of the Data lines (DO-D7) should be held high, low, or floating (C5). Check for clock signals PCC and SCL (C5).

Look for input changes on U1 and U5 of the color circuit (C6); also, pin-3 of U4 should be active high and low. (See figure 1 in the illustrations section).

When the monitor is suspected of a problem, check for all correct power supply voltages as shown in the schematic. Isolate incorrect voltages to either the monitor power supply or to the circuit receiving the voltage.

NOTE: The Color X-Y Monitor contains a circuit that shuts off the high-voltage oscillator when no vertical or horizontal inputs are present. DO NOT ATTEMPT TO RAISE OR LOWER EITHER INPUT WHEN TESTING THE MONITOR. DOING SO WOULD CREATE EXCESSIVE DEFLECTION CURRENT THAT COULD SEVERELY DAMAGE THE MONITOR. For testing the monitor, use only the outputs of the G-80 hardware. In addition, DO NOT operate the monitor WITHOUT proper fuses in the main AC line. If a monitor is blowing main fuses, check the deflection amp power transistors Q605, Q606, Q705 and Q706, WITH THE POWER OFF. Shorted transistors or diodes in the deflection amplifiers will also blow main line AC fuses.

Check the transistors in the color drive circuits for shorts or opens when one or more colors is missing from the display, and the G-80 boards are known to be good.

## COLOR X-Y MONITOR AND G-80 CIRCUIT DESCRIPTION

To begin our discussion of the Color X-Y Monitor, let's first pay tribute to the "other kind of monitor" - the raster-scan. As you may remember from your knowledge of raster-scan displays (like those in a TV), that the electron-beam inside the tube always moves in a predictable way. That is, it always starts at the top left of the screen and scans across it, forming a pattern of horizontal lines on the inside surface of the tube as it moves downward. When it gets to the bottom, the beam is forced back to its starting point and repeats the raster-scan movement. To create a simple display (for example, a large "+" symbol) on the raster-scan monitor, we figure out first, where we want it to appear on the screen; let's say the center, in this case. Then we generate a video signal that represents the "+", plug the signal into the monitor, and we get a "+" on the display. What we have done is intensify the electron-beam so that only those points corresponding to the "+" light up on the raster. (To see how it would look close-up, refer to figure 2 in the illustrations section.)

Notice how the vertical line is not much of a line, but more a column of stacked lines. This occurs because the raster lines, which run horizontally inside the CRT, are spaced slightly as the beam traces them. So what we see, looking at our line from top to bottom is a tiny segment of the lit up raster, then a black space, another lit up segment, another black space, and so on. Now the horizontal line of our figure is perfect, one solid, lit up line corresponding to that particular "raster". The fact that you can't get high-quality traces in both directions is what led to the development of the X-Y monitor. If we create that same centered "+" on an X-Y display, we would see two perfect, solid lines - no gaps anywhere. (Refer to figure 3.) What produces the high-quality, solid lines in any direction in an X-Y monitor is the electron-beam inside the CRT (there are actually three electron-beams, one for each of the three colors, red, green, and blue, although it is often simpler to think of it as one beam). Unlike the beam in a raster-scan unit, the X-Y beam can be moved in any direction we choose. All we have to do is determine where we want to move it. We also need to tell the beam when to turn on, or intensify, to "draw" the design we want, how big to make the

design, what color the lines should be, what angles the lines will take, and when to stop drawing. For now, remember that we are directly influencing the X-Y beam to create our lines by moving it and turning it on when necessary; in the raster-scan, all we had to do was turn on the beam at the right times.

Important differences between the raster and X-Y monitors are that the X-Y's have no need for vertical or horizontal oscillators and drive circuits, since these predetermine the electron-beam's movement. Also, no flyback pulse is needed in the X-Y to move the beam to the top of the raster. However, a very high voltage is still necessary in the X-Y to attract the electron-beam to the front surface of the tube.

Before we delve into the circuits that make up the color X-Y monitor, let's consider how we actually control an electron-beam. Inside the picture tube neck, there is a piece of metal called a cathode. When it is charged with a voltage, it generates electrons. As the electrons are emitted, they are shaped to form a thin ray, or beam, that strikes the front of the monitor. The only way the beam will move up or down, left or right is if a magnetic field is applied around the beam. This is what the deflection coils located around the CRT neck do. There are two coils, one to move the beam up or down (VERTICAL DEFLECTION COIL) and one to move it left or right (HORIZONTAL DEFLECTION COIL). So, by running some current through either coil, we create a magnetic field around the beam to deflect it in any direction. The larger the current we put through either coil, the stronger the magnetic field and the more the beam will deflect.

While we're on the subject of beam movement, consider why this monitor is called an "X-Y monitor". Picture our "+" symbol on the screen again; the horizontal line is called the "X" axis and the vertical line is the "Y" axis, hence "X-Y monitor". Make a mental note that when we move the beam horizontally, we are moving it on the X-axis; moving the beam vertically occurs on the Y-axis. Let's look closer at the color X-Y monitor circuits and see where this deflection coil current comes from. (For the following explanation, please refer to the schematic of the monitor in this manual.) The circuitry primarily consisting of IC 600 (15-2156-01) accepts two varying voltage levels, one for Vertical, one for Horizontal, from the G-80 boards. These



voltages are called ANALOG signals because they represent all voltage levels between two pre-determined levels.

Let's say that we want an analog signal that can vary between two voltages, +3 and -3 volts. We could control it to look like this on an oscilloscope:

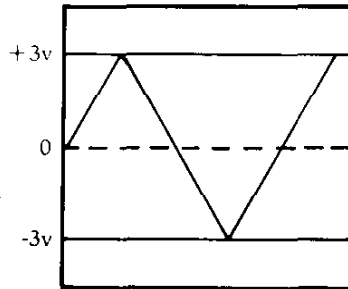

As the signal changes, it moves through all possible voltage levels that exist between +3 and -3 volts. Don't confuse this type of signal with a digital one. The digital signal switches between 0, and typically, +5 volts. It does not drop to a negative voltage level. As these varying voltages come into the X-Y monitor, they activate, first the Input Driver, intended to set a proper reference, and the X and Y power amplifiers (Q 600-606, Q 700-706). These amplifiers control the current that flows into the X and Y deflection coils, depending on the voltage levels on the inputs, and the input current set by Limiters Q 201, 202, 251, 252. Remember that this current controls the electron-beam movement, so if we vary the input voltage, we vary the output current and the direction of the beam. The following chart will clarify this:

	<u>INPUT VOLTAGE</u>	<u>BEAM MOVEMENT</u>
Y-AMP	Positive	Up
(Vertical)	Negative	Down
X-AMP	Positive	Right
(Horizontal)	Negative	Left

Earlier, we said that there has to be a way to turn on, or intensify the electron-beam to create an image on the screen. Well, there are three more inputs to the X-Y that allow us to do just that; they are the color inputs R,G,B and they accept analog signals from the G-80 hardware. These color

signals activate the three color electron-beams through the circuits in the Video PCB. Using what we know so far, let's apply it to an actual example of drawing something simple on the screen - a white line for instance. (Refer to figure 4 - illustrations section.)

Point A, the center of the screen, is the starting point for the electron-beam. To move the beam to point B, we have to supply voltages to the monitor's inputs that cause the beam to move at a 45 degree angle. To do that requires two increasing positive voltages on the horizontal and vertical inputs. (See the chart above). Not only are these voltages positive in this case, they also have to be equal. And if they are equal, the deflection coils will force the beam the same distance both upward, and to the right, at the same time. Moving at any other angle is just a matter of making one coil deflect more or less than the other. Again, notice that both coils force beam deflection simultaneously.

Since we don't want this 45 degree line to show up on the screen, we don't feed any voltages to the RGB inputs. But, we know the beam is at point B, awaiting further deflection. Now, we cause the voltage on the horizontal (X) input to go negative and leave the vertical voltage where it is. Also, we turn on the RGB inputs to give us a white line. From the chart, you can see that these voltages will cause the beam to move to the left, horizontally, to point C. Our line is complete, and here is what our input signals looked like during this process:

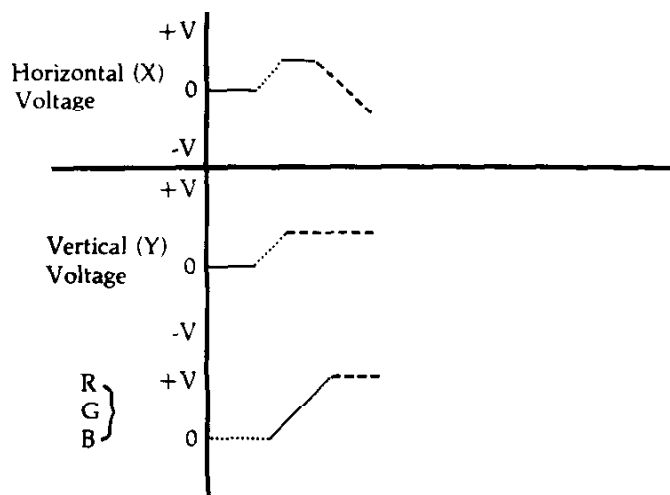

In our example, we made a very short line, considering we could have drawn one clear across the screen. In order to draw longer lines, in any direction, we simply increase the positive or negative voltage on the inputs. Remember - the higher the voltage, the more the deflection, the longer the line.

The remaining circuits in the monitor are a power supply, a CRT and brightness control (CRT PCB), and high voltage generator. Here are Functional Block, and Signal Flow diagrams for the Color X-Y Monitor:

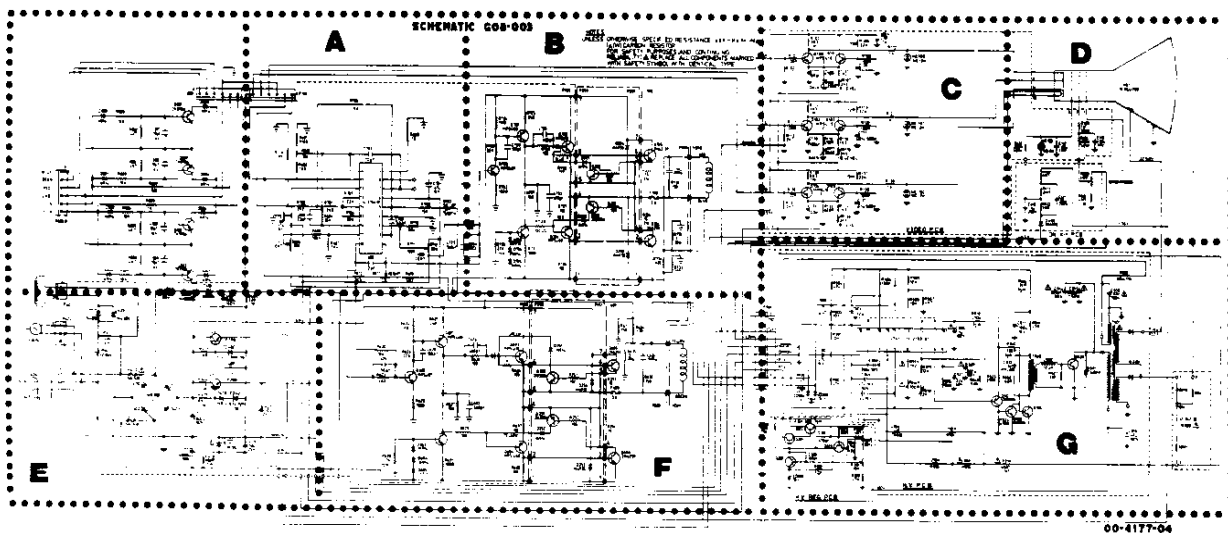

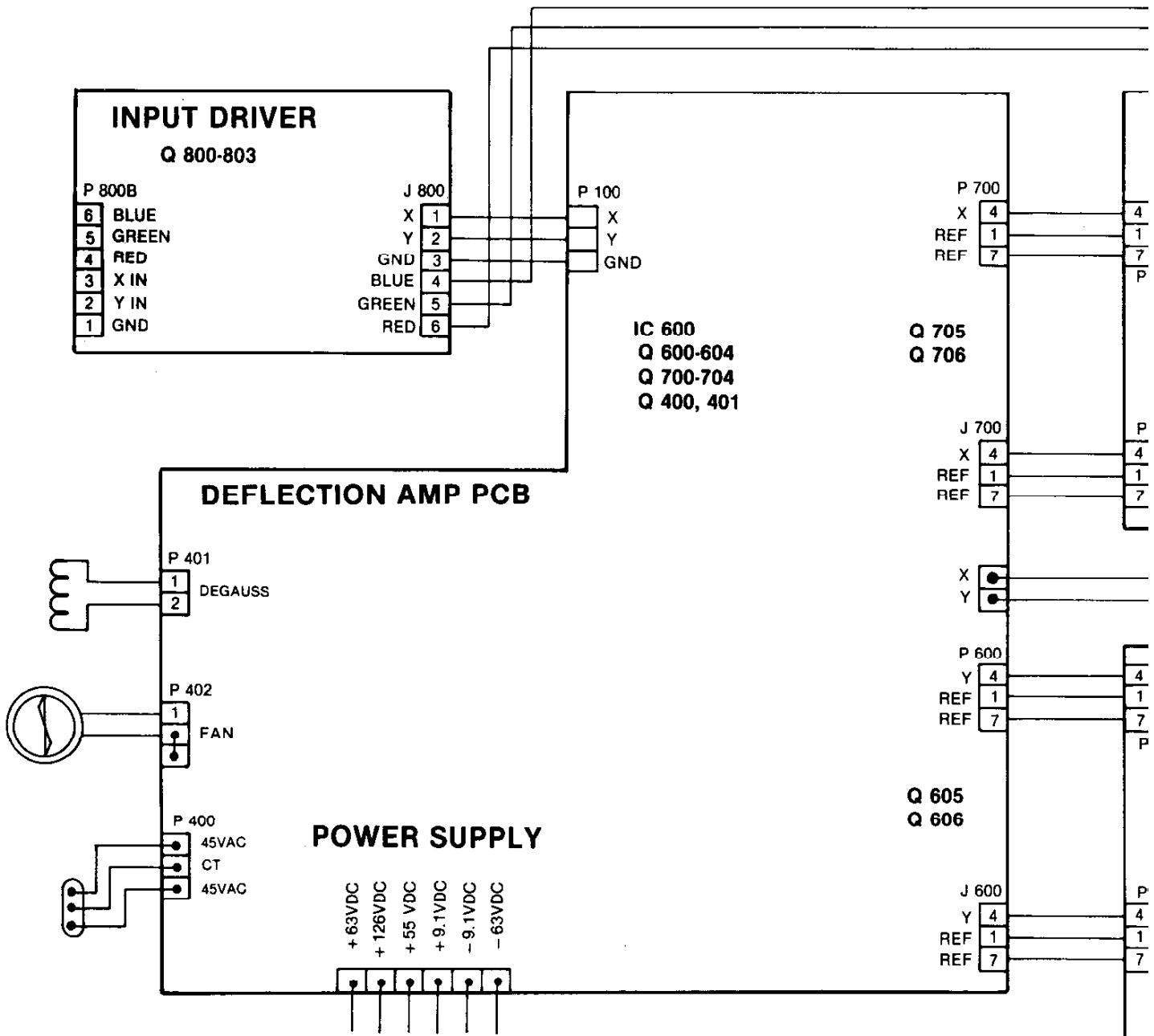

# COLOR X-Y MONITOR

MODEL G08-003

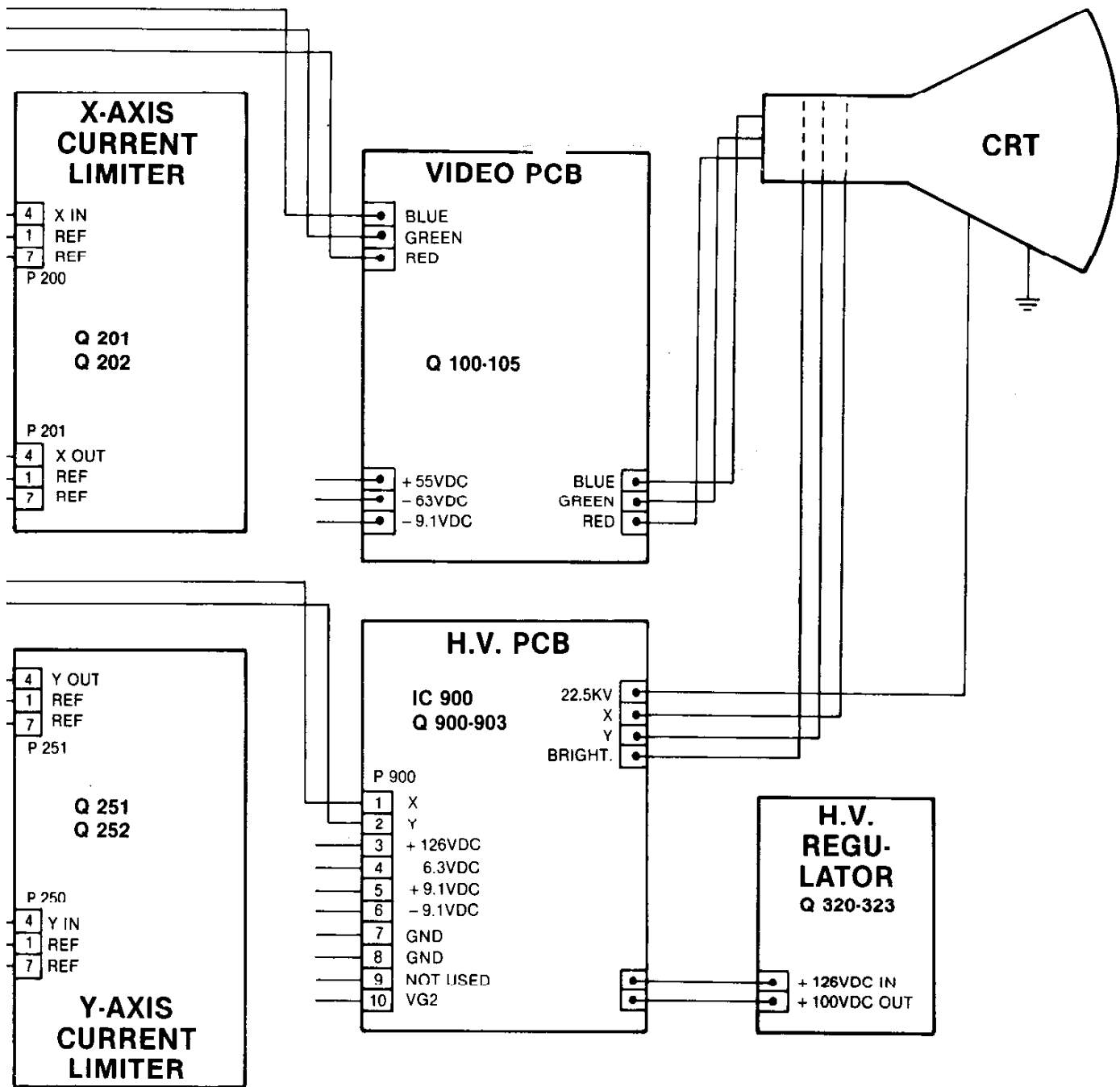

Referring back to the monitor schematic for the following discussion, the circuitry in block A serves two purposes. First, it compensates for a type of distortion known as the pin-cushion effect. This occurs because the electron-beam must travel a greater distance when striking the edges of the CRT than when it hits the center. If we cause the beam to trace along the edges of the CRT, the beam would draw a box with its left and right sides bowed inward. To compensate for the effect, this circuit offsets the point where the beam would normally strike the CRT surface.

Secondly, this circuit contains two error amplifiers, one for the horizontal and one for the vertical inputs. Each error amp has two inputs; one is set to zero volts, the other accepts the analog signal from the G-80 system, sensing current movement in the deflection coil. The analog signal is allowed to pass through the error amps and drive the deflection (power) amps. The deflection amps are shown in blocks B and F. The outputs of the X and Y power amps pass current through their respective deflection coils. The output leads of the two coils are connected back to the analog inputs of the respective error amps, as mentioned above. This acts as an error, or feedback, signal and ensures that the current through the deflection coil remains proportional to the voltage on the error amp inputs. If this signal were not provided, there would be a slight deflection error when an analog input signal was present.

The outputs of the X and Y deflection amps can swing between +60V and -60V. This voltage is high enough to provide up to 8 amps, peak-to-peak, of current through the deflection coils.

The color drive circuits are located in schematic block C and they accept a 4 volt maximum signal on the RGB inputs. The outputs drive the three electron-beams in the CRT. Three neon glow-bulbs, NE-100, 101, and 102 act as spark arrestors for the color-drive outputs to the CRT. In block D, the CRT is shown, as well as the brightness adjustment for it. The circuit of D 409, R 411, R 410 is a spot-killer that prevents the electron-beams from burning a hole in the phosphor surface of the CRT when the monitor is turned off. Section G of the schematic consists of the high-voltage oscillator in IC 900 (14-2155-01) which operates the high-voltage transformer, T 901. This transformer is technically a flyback type, but it is not used to deflect the beam.

The IC serves two other functions; it senses the presence of the 10.3KV through R 921 and R 932 and compares it against the 9.1 supply voltage to ensure a regulated output, and also senses the varying current in either deflection coil. If no change is detected, the IC shuts down the high-voltage oscillator to prevent the beam from "burning" the face of the CRT.

Finally, the X-Y power supply is shown in block E, generating the following voltages:

- +60V to X-Y power amplifiers
- +55V to RGB video drivers and spot killer
- +9.1V to the IC's
- +120V to the EHT oscillator

A degaussing circuit is provided through D 404, D 405, and R 400. The CRT is automatically degaussed when R 400 is cooled sufficiently to conduct current through the degaussing coil.

### G-80

It's not hard to imagine how fast the input signals to the color X-Y monitor must be changing in order to produce the game displays. It's also obvious that a computer must be making all this happen. That is exactly the case with the G-80 hardware used in Color X-Y game. It contains two new boards, the X-Y Timing and X-Y Control boards that produce the X-Y monitor input signals. The G-80 still relies on its CPU, EPROM, Sound, and Speech boards to complete the computer.

But what does a digital computer have to do with producing the analog signals required by the X-Y monitor? Basically, the computer converts certain digital signals into analog ones. On the G-80 X-Y boards are circuits (some are actually single IC's) called Digital-to-Analog converters, D/A for short. These circuits accept a particular digital word, that is, a string of 0 and +5V voltage levels. The D/A converter senses the word and outputs one and only one voltage level which corresponds to the digital word. For example, we could design a simple D/A converter that would generate the following voltages when we input certain digital words:

DIGITAL WORD	ANALOG OUTPUT
--------------	---------------

0000	-1 Volt
1111	+1 Volt
1000	0 Volt

This is a very basic case, but it shows that, for a particular D/A converter, we always produce one voltage level from the corresponding digital input. If we cycle through a variety of digital inputs, we'll get a variety of output voltages. If we do this fast enough, we actually create a rapidly varying range of output voltages. This output is exactly the kind of signal we need to drive the deflection coils in the monitor.

Now that we know where the analog signals come from, what about the digital ones? Before we can display anything on our X-Y screen, we have to ask some questions: (Answers are provided for examples sake)

QUESTIONS	ANSWERS
1. What do you want on the screen?	A triangle.
2. How many?	One.
3. What design? - What angle? angles).	Equalateral (3-60 <sup>0</sup>
4. What size?	3" on a side.
5. Positioning? screen.	Centered on the
6. What colors? blue.	2 sides white, 1 side
7. Screen alignment?	Like this:





8. What will it do?

Just sit there.

9. How many lines does the electron-beam have to trace?

In our triangle, the beam must make 4 lines:

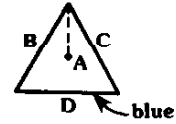

A (even though we don't see it), B, C, and D.

Now that we have our specifications, we have to store this information someplace so the Timing and Control boards can get to it and understand. That place is video memory RAM (or Random Access Memory). It holds 4096 eight-bit words or bytes. Naturally, we don't place all this into memory and hope the X-Y boards can find it; it's stored in an orderly fashion.

First, we divide the video memory into two main groups - let's call them 1) The Symbol Instructions and, 2) The Line Instructions. Into the Symbol Instructions Section we store one group of ten words for every symbol or design we put on the screen. In our example, we have only one symbol, so we use only 10 words. Into the Line Instructions Section we put one group of four words for every Line that the beam has to draw. So, for our triangle, which requires 4 lines, we would store 4 groups of 4 words in the Line Instructions space. Every word we store in memory has one and only one address, so the same word can be called on over and over. Now let's look closer at the Symbol Instructions memory space. Here is what the 10 words do: (Don't be concerned with the actual values of those words right now.)

WORD 1        It tells the X-Y boards either to make the beam draw the symbol in this group of words or not to draw it. And the same word informs the boards that either this group of words is the only group or that there are more 10-word groups to follow.

WORD 2 and 3 These tell the boards where the beam is on the X-axis.

WORD 4 and 5 These tell the boards where the beam is on the Y-axis. The last four words then, give the exact coordinates of the electron-beam.

WORD 6 and 7 Words 6 and 7 tell the X-Y hardware what the first address is of the Line Instructions section.

WORD 8 and 9 These tell the hardware how the complete symbol (our triangle) will appear on the screen, or at what angle.

WORD 10 This word tells what the overall size of the design will be.

Again, since we're only making one design, there will be no more 10-word groups after the one above. Now take a look at the Line Instructions section of memory:

GROUP 1

WORD 1 This word tells the G-80 boards either to blank or to unblank the line. And, it informs the boards that either additional 4-word groups follow or no more groups follow. Finally, it defines the color this particular line is to be.

WORD 2 This word represents the length of the line the beam is to draw.

WORD 3 Word 3 tells the hardware at what angle the beam should make its line.  $45^{\circ}$ ?,  $90^{\circ}$ ?

WORD 4 Word 4 defines in which of the four sections of the screen the line is to appear - which quadrant.

The remaining 4-word groups contain the same representations of their respective lines, as in Group 1. The values will be different, of course,

depending on how the lines differ. In our triangle example we would find 3 more groups of four words after Group 1.

By now, you may be wondering what all these "words" really are. Since we are dealing with a digital computer, the "words" we described above must be digital. More accurately, they are digital values of the specifications required to create our designs. We have taken the specifications for sizes, angles, shapes, colors and locations and converted them into digital words and create displays that the word represent.

Before we go any further, you should know that the words read from the video RAM didn't get there by magic. The microprocessor put them there. All words that represent all the characters and designs in a game are kept safely in EPROM (Erasable Programmable Read Only Memory), on the EPROM board. When the game is powered up the CPU moves the various word groups from EPROM to RAM. Once situated in video memory, the words are made available to the Timing and Control boards to create displays. Briefly, here is what the two X-Y boards do with the words:

After all the character words are loaded into video RAM, the Program Counter is forced to call on the first RAM address. Here the Program Counter finds the first word in the Symbol Instructions section. One at a time, these ten words are taken out of RAM and latched into specific parts of the X-Y boards. This sequence is controlled by the Timing Generator which generates 15 active-low signals; only one signal pulses low at a time to latch the words. Next, the following sequence occurs:

1. Word 1 is latched into U52, Last Symbol block.
2. Words 2 and 3 (from the Symbol Instructions) are loaded into the X-axis Up/Down counters.
3. Words 4 and 5 are loaded into the Y-axis Up/Down counters.
4. Words 6 and 7 are stored in the Vector Address counter.
5. Words 8 and 9 are stored in the Symbol Angle latch.

6. Word 10 is loaded into the Serial Multiplier.

Now the first 10 words of a character we wish to display are stored somewhere. If we had not wanted to draw this character, the Program Counter would have jumped to the next set of 10 symbol words, if there were another symbol. Once the Program Counter is finished moving out the words, the Vector Address counter takes control of memory. This switching between the Program and Vector Address counters is governed by the Multiplexer. Through it, the G-80 Address Bus or one of the other counters can address video memory. Only one device is allowed access to memory at a time. When it is the Vector Address counter's turn to get into memory, the counter addresses the first word of the Line Instructions section. The reason for this, is that the Vector counter was previously loaded with words 6 and 7 in the Symbol Instructions section. These words tell the Vector Address counter the locations of the first word in the Line Instructions section. Now the Vector counter causes the Line Instruction words to be moved out of memory, one at a time. Here is what happens to the group of four words:

1. Word 1 is stored in the Color Latch and in U52, Last Vector.
2. Word 2 is stored in the Vector Length counters.
3. Word 3 is loaded into the Vector Angle circuit.
4. Word 4 is used in the Vector Angle circuit.

Up to this point then, 10 words that describe some symbol and 4 words that represent one line in that symbol have been clocked out of memory. When the Vector Address counter takes out the last group of words that represents the last line to be drawn, memory access is switched back to the Program Counter. It will now either restart the sequence as before (if there is another symbol to be drawn) or it will stop until the counter is reset to the beginning again.

Now the system is ready to draw its first line, to actually move the beam, because we have given it exact specifications to do so. The position of the electron-beam is now known, (Words 2 through 5 in the Symbol Instructions) so

we know where the beam will start to draw. Then, the X-Y boards calculate the length and angle of our first line. And they know the color, if any, of this line. (In our triangle, recall that our first line, A, is one that we shouldn't see, although it must be drawn. We also know that it must be drawn at a  $0^{\circ}$  angle, straight up.) The boards calculate the line length and angle by assigning a certain number of digital clock pulses to these qualities. The circuitry acts as a digital "ruler" and "protractor" and measures any line, in terms of how many pulses in length and angle it is. All this figuring is performed by the Full Adder's, 2708 EPROM and Rate Multipliers. The output of each Rate Multiplier (XCL and YCL) is a string of clock pulses that clock the respective Up/Down counter, X or Y. But the pulses are not just random pulses, they are the digital equivalents of a line with a particular length and angle. So we clock both Up/Down counters at the same time with these pulses. Doing so we force the counters to start counting from the beam position words previously stored in the counters. The important point is this; if we change the digital values of the beam position words, we change the position of the beam through the D/A converters. How far, and at what angle we change the beam depends on the amount of pulses applied to the Up/Down counters. Just before the beam is moved, the color of the line (black included) is sent to the monitor through the RGB D/A converters.

There you have it - one line. For more lines, the G-80 system rapidly follows the same procedure of reading the symbol and line words, latching them, calculating line values, color values, and then forcing the beam line-by-line to form complete symbols.

Notice that throughout our discussion, we have mentioned the micro-processor's role just once; loading the character word into memory. During an actual game however, it does more than act as a "loader". Whenever we want to move our symbols on the screen, for example rotate the triangle, we need some way of changing all those words to represent new lines and angles. The CPU fulfills this job nicely. Under program control, the CPU is told when and how to alter these words to create a whole range of dynamic displays - different colored lines, new angles, longer or shorter lines, bigger or smaller characters, whatever the game play calls for. Also, the microprocessor governs functions such as player control and coin inputs, or sound and speech outputs.

The CPU then, gives us the variety and color in our X-Y games. - PLEASE NOTE: The designations in parenthesis will be used throughout the following detailed discussion to refer the reader to the proper schematics. C = X-Y Control Board (P/N 800-0163) sheets 5 and 6. T = X-Y Timing Board (P/N 800-0161) sheets 5, 6, and 7. e.g. (C6) = Control Board, sheet 6.

The CPU addresses video memory, U24-U31, through multiplexer IC's U48 and U49 (C5). Character words are taken from memory as the Program Counter, ICs U33, U34, U22 (C5), addresses them through multiplexers U36, U49, U35, and U21 (C5). If Word 1 (Symbol Instructions) says to not display a symbol, the Program Counter is advanced 10 counts by U33, a full adder, which adds 10 to the counter when signal ADD goes low. The Vector Address counter is composed of U10, U11, and U12 (C5) and is loaded with the first address of the Line Instructions from video memory's Character Data Bus, CDO-CD7. The CPU's Data Bus, DO-D7, is brought to the memory through a bi-directional buffer, U14 (C5). The signal labelled FETCH (C5) latches the various Character Data words from memory. The MUX (C5) signal commands the multiplexer ICs to allow either the CPU, Program Counter or Vector Address counter to address memory. MEMR (memory read) and MEMW (memory write) come from the CPU board to read from or write to the RAM. Signal VCE (C5), Vector Clock Enable, increments the Vector Address Counter. PCC (Program Counter Clock) is the string of pulses that advances the Program Counter; PCR (Program Counter Reset) ensures that the Program Counter starts counting at the first location in video RAM each time PCR goes low. This signal occurs first at power-up and then 40 times a second during program execution. So, it causes the X-Y monitor to draw and re-draw each symbol on the screen 40 times a second. The signal is generated from the master clock (crystal Y1 and U14, T7) by U31-U34 and U22 (T7). The other clock signals (VCE, PCC, FETCH, ADD, MUX, and VCL) are all generated by the X-Y Timing board (T7).

The outputs of the Last Symbol and Last Vector latches (U52, T7) are AND gated together with the signal END, which originates from the Control board's U18 (C6). When U18's output goes low, it signifies that no more symbols are to be drawn. Then the Program Counter is reset by the 40 Hz signal to the start of the video memory to repeat the display sequence. U22 (T7) is the DRAW latch and its output, through U21, creates the DRAW signal which initiates a

sequence that causes the beam to draw. This sequence occurs on the Timing Board, sheet 6; by this time, all video words have been stored in their proper places in the system. On the Timing Board (T7), the vector angle is in U56, the symbol angle in U55. So when DRAW goes high, it causes strings of digital pulses that represent the vector and symbol angles to be generated. These streams of pulses (from U28, T6) are the ones that clock the X and Y Up/Down counters, shown on T5 (U15-U20). U25 (T6) tells the counters in which direction to count, up or down (D/U X, D/U Y). Then, the outputs of the Up/Down counters, X and Y, become the digital words that are converted to analog signals by D/A converters U1 and U4 (T5). On Amps U2 and U3 (T5) convert current from the D/A converters to voltage levels. These levels drive the Vertical and Horizontal inputs to the monitor. Signals DRAW and VCL are combined in U28 (T6) to form DCL (Draw Clock). This signal clocks down the Vector Length counters U15, U16 and U17 (C6) which contain words that represent various lengths of the lines to be displayed. When the counters have counted down to 0, the END signal becomes active. As the X and Y Up/Down counters are clocked, their outputs are sensed by U5-U10 (T5), which are multiplexers. The multiplexers are necessary to tell the system when the beam is off the screen. It does this by generating the BOS signal (T5). Then BOS is AND gated with DRAW at U5 (C6), to blank (turn off) the beam whenever BOS goes low.

U3 (C6) compensates for the inherent delay in deflecting the electron-beams. It provides a number of taps to select a range of delay times. From U2 (C6), the color word is read and applied to the RGB D/A converters U5, U1 and associated diodes and resistors. The RGB outputs go directly to the color X-Y monitor.

U50, a 74LS154 (T7) decoder IC, selects one of 15 outputs by making the output low. The outputs sequentially store the video memory words, one at a time. U50 is enabled at pin 18, forty times per second by U22 (T7), and at pin 19 by U21. U51 sequences U50 through its 15 count cycle; at count 14, pin 16 of U50 goes low to initiate the DRAW signal through U40, U21 and U22 (T7).

The circuitry at the top of schematic C6 (U45, U51-U54) is not used in generating and displaying characters on the X-Y monitor. Its function is to perform lengthy calculations under software control.

## ADJUSTMENTS AND SPECIFICATIONS

On the X-Y Timing Board, there are two potentiometers that adjust the outputs of the X and Y current-to-voltage converters (U2 and U3, respectively); they are:

R3 (X)	U2
R6 (Y)	U3

On the monitor, there are a number of factory-set adjustments. DO NOT USE THESE CONTROLS. They are:

R106	R917
R117	R918
R611	R920
R702	

The following controls can be used to adjust the monitor if necessary:

R605	Vertical
R712	Horizontal
R107	Red
R118	Green
R136	Blue
R930	Brightness
R922	Focus

Input specifications from the G-80 boards to the color X-Y monitor are:

Vertical Input	+3V maximum	
Horizontal Input	+4V maximum	
Red Input		+4V @ full brightness
Green Input	+4V @ full brightness	
Blue Input	+4V @ full brightness	



VOLTAGE ANALYSIS FOR THE G08-003 COLOR X-Y MONITOR

DEFLECTION PCB

P 900 (EHT)

Pin 1	2.8 VAC
2	3.5 VAC
3	-9.1 VDC
4	9.1 VDC
5	GRD
6	GRD
7	5.0 VAC
8	120 VDC
9	OPEN
10	400 VDC

D 401 - cathode 63 VDC

D 403 - cathode 63 VDC

D 400 - anode -63 VDC

D 402 - anode -63 VDC

ZD 400 59 VDC

ZD 401 9.0 VDC

ZD 402 -9.1 VDC

Q 400 - base 59 VDC, - emitter 58.8 VDC, - collector 63.5 VDC

Q 401 - base 9.7 VDC, - emitter 9.1 VDC, - collector 17 VDC

IC 600

Pin 1	0	10	0
2	4.2 VDC	11	0
3	0	12	-9.1 VDC
4	0	13	0
5	0	14	0
6	9.1 VDC	15	0
7	7.5 VDC	16	0
8	0	17	0
9	0	18	4.2 VDC

Q 600 - collector 34.5 VDC

Q 700 - collector 35.9 VDC

Q 601 - collector 0.8 VDC

Q 701 - collector 0.5 VDC

Q 602 - collector	-0.5 VDC	Q 702 - collector	-0.8 VDC
Q 603 - collector	63.5 VDC	Q 703 - collector	63.5 VDC
Q 604 - collector	-63.9 VDC	Q 704 - collector	-63.5 VDC
Q 605 - collector	63.9 VDC	Q 705 - collector	63.9 VDC
- base	0.1 VDC	- base	0.1 VDC
- emitter	0.1 VDC	- emitter	0.1 VDC
Q 606 - collector	-63.9 VDC	Q 706 - collector	-63.9 VDC
- base	-0.1 VDC	- base	-0.1 VDC
- emitter	-0.1 VDC	- emitter	-0.1 VDC

EHT PCB

IC 900

Pin 1	0.4 VDC	10	1.7 VDC
2	0	11	8.7 VDC
3	0.1 VDC	12	8.7 VDC
4	-9.1 VDC	13	2.3 VDC
5	9.0 VDC	14	9.0 VDC
6	0.7 VDC	15	0.5 VDC
7	1.7 VDC	16	0.1 VDC
8	7.5 VDC	17	8.7 VDC
9	0.1 VDC	18	0
Q 901 - emitter	8.0 VDC		
- base	7.5 VDC		
- collector	0.3 VDC		
Q 902 - emitter	0		
- base	0.3 VDC		
- collector	0.5 VDC		
Q 903 - emitter	0		
- base	0.5 VDC		
- collector	3.0 VDC		

# Illustrations

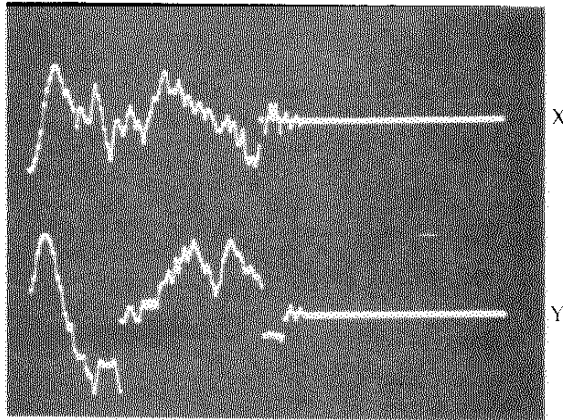

Figure 1

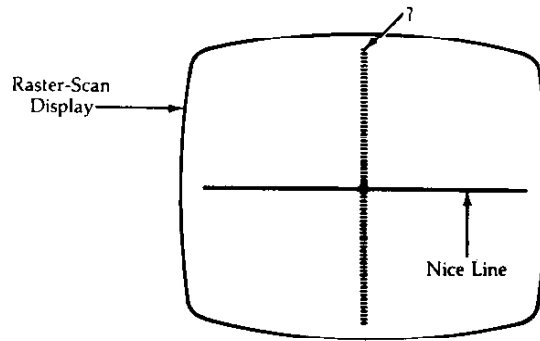

Figure 2

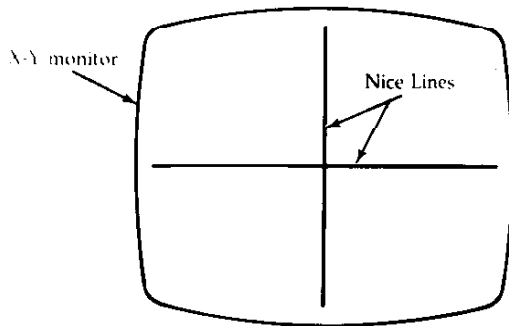

Figure 3

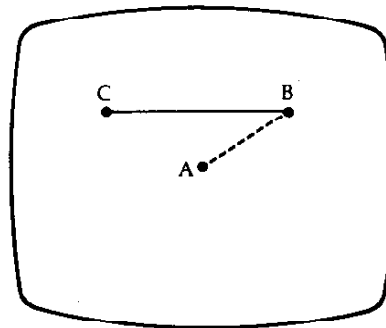
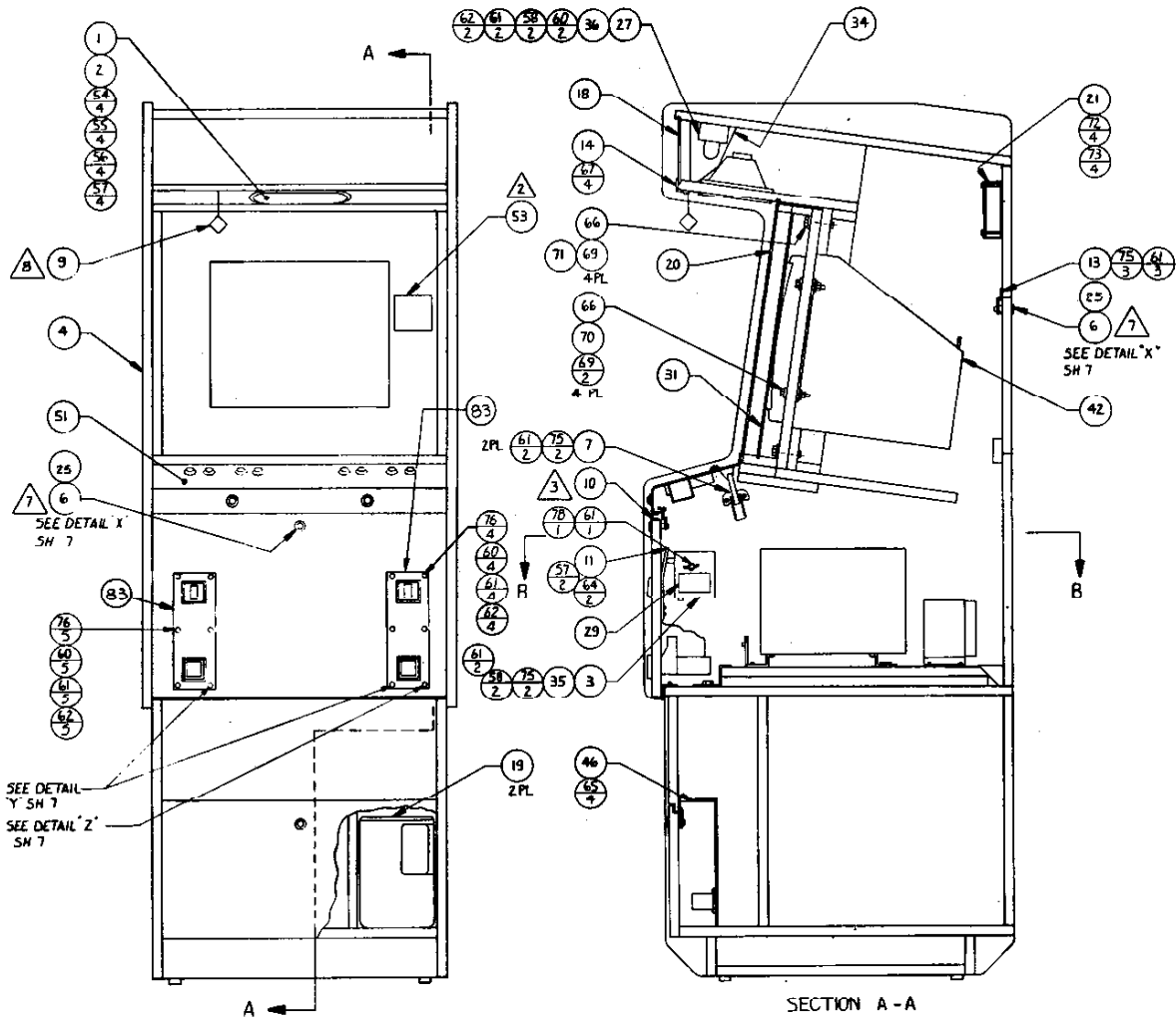

Figure 4

<u>ITEM NO.</u>	<u>PART NO.</u>	<u>QTY REQD.</u>	<u>DESCRIPTION</u>
1	130-0020	1	Speaker Game 6 x 9, 10W
2	130-0002	1	Speaker Cover 6 x 9
3	140-0021	1	Cover J-Box
4	140-0055	1	Cabinet Universal Upright
5	220-0194	2	Coin Mech/W Light
6	220-0167	2	Lock Coin Mech Door (& Back)
7	220-0178	2	Draw Latches
8	200-0025	1	19" X-Y Monitor
9	420-0636	1	Tag, Extra Value
10	250-0038	1	Molding Strip
11	250-0048	1	Clip Switch
12	250-0458	1	Saddle G-80 Cage
13	250-0481	1	Strike Plate
14	250-0492	1	Molding Logo Panel
15	250-0497	2	Clamp Component Board
16	420-0800	1	Decal, Dipswitch
17	280-0345	11	Tie Wrap, Screw Mounted
18	253-0272	1	Panel Logo
19	253-0222	2	Coin Receptacle
20	253-0228	1	Monitor Panel Clear
21	800-0295	1	Assy Fan Cabinet
22	280-0005	30	Cable Tie
23	280-0324	2	Cable Clamp Nylon
24	280-0327	8	Base Tie Wrap
25	280-0360	2	Washer Lock, Lock
26	280-0359	2	Crimp Sleeve
27	390-0019	1	Lamp Fluor
28	420-0798	1	Game Instruction Decal
29	420-0030	1	Decal Caution
30			
31	420-0796	1	Graphic Interior
32	420-0795	1	Manual

<u>ITEM NO.</u>	<u>PART NO.</u>	<u>QTY REQD.</u>	<u>DESCRIPTION</u>
33	420-0568	1	Decal FCC
34	420-0624	1	Light Baffle
35	800-0145-01	1	Assy J-Box
36	800-0147	1	Assy Fluor Lamp 2
37	800-0178	1	Assy Harn Power
38	800-0190	1	Assy XFMR EMI
39	800-0191	1	Assy Game Power Supply
40	800-0192	1	Assy Speaker Harn
41	800-0232	1	Assy Harn Gnd Intf Mech
42	420-0656	1	Decal Self-Test Instructions
43	800-0255	1	Assy Harn AC Monitor Intf X-Y
44	800-0277	1	Assy Vol Control Block
45	800-0279	1	Assy Conn Bracket
46	800-0280	1	Assy Coin Counter
47	800-0284	1	Assy Harn Gnd Coin Mech Univ.
48	800-0285	1	Assy Harn Gnd Game Elec. Univ.
49	800-0286	1	Assy Harn Gnd G-80 PS Univ.
50	800-0290	1	Assy Gnd Strap Control Pnl Univ.
51	800-3265	1	Assy Control Panel
52	800-3267	1	Assy Game Electronics
53	800-0315		Assy Harn Coin Mech Lighting
54	281-0014-28	4	Scr Oval Hd Mach #8-32 x 1.750
55	283-0024-00	4	Nut Hex Mach #8-32
56	284-0004-00	4	Washer Flat Std O.D. Steel #8
57	284-0034-00	6	Washer Lock Split Steel #8
58	284-0016-00	25	Washer Flat Small O.D. Steel #10
59	800-0276	1	Assy Harn Coin Mech
60	282-0005-20	11	Bolt Carriage Hd Mach #10-24 x 1.250
61	284-0036-00	45	Washer Lock Split Steel #10
62	283-0025-00	17	Nut Hex Mach #10-24
63	282-0005-24	3	Bolt Carriage Hd Mach #10-24 x 1.500
64	281-0044-08	2	Scr PN HD Phl S/M Type A/AB #8-15 x .500

<u>ITEM NO.</u>	<u>PART NO.</u>	<u>QTY REQD.</u>	<u>DESCRIPTION</u>
65	281-0052-08	4	Scr 82 <sup>0</sup> Flat HD Phl S/M Type A/AB #6-18 x .500
66	282-0017-24	8	Bolt Hex HD Mach #1/4-20 x 1.500
67	286-0044-12	4	Scr PN HD Phl S/M Type A/AB Blk #8-15 x .750
68	282-0017-16	2	Bolt Hex HD Mach 11 1/4-20 x 1.000
69	284-0027-20	14	Washer Flat 1.250 O.D. Steel #1/4
70	283-0007-00	4	Nut Hex Self-Locking Mach #1/4-20
71	284-0037-00	10	Washer Lock Split Steel #1/4
72	281-0042-32	6	Scr PN HD Phl S/M Type A/AB #6-18 x 2.000
73	284-0002-00	4	Washer Flat Std O.D. Steel #6
74			
75	281-0045-12	27	Scr PN HD Phl S/M Type A/AB #10-12 x .750
76	284-0006-00	12	Washer Flat Std O.D. Steel #10
77	281-0074-12	11	Scr 82 <sup>0</sup> Flat HD Phil Wood #8-15 x .750
78	283-0015-00	1	Nut Wing Mach #10-24



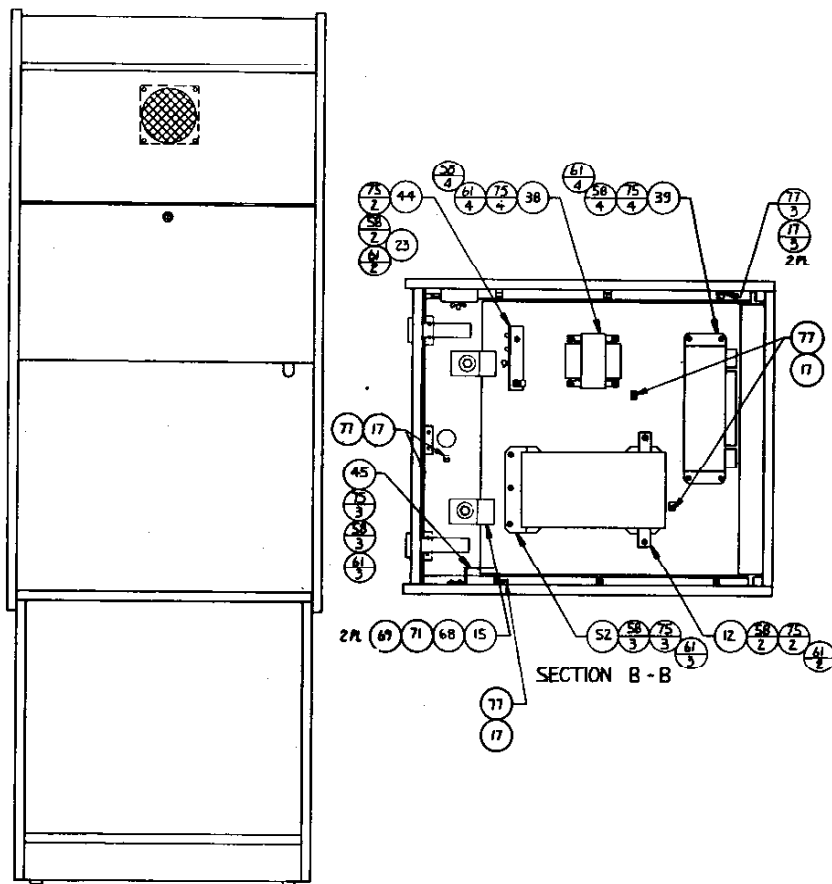



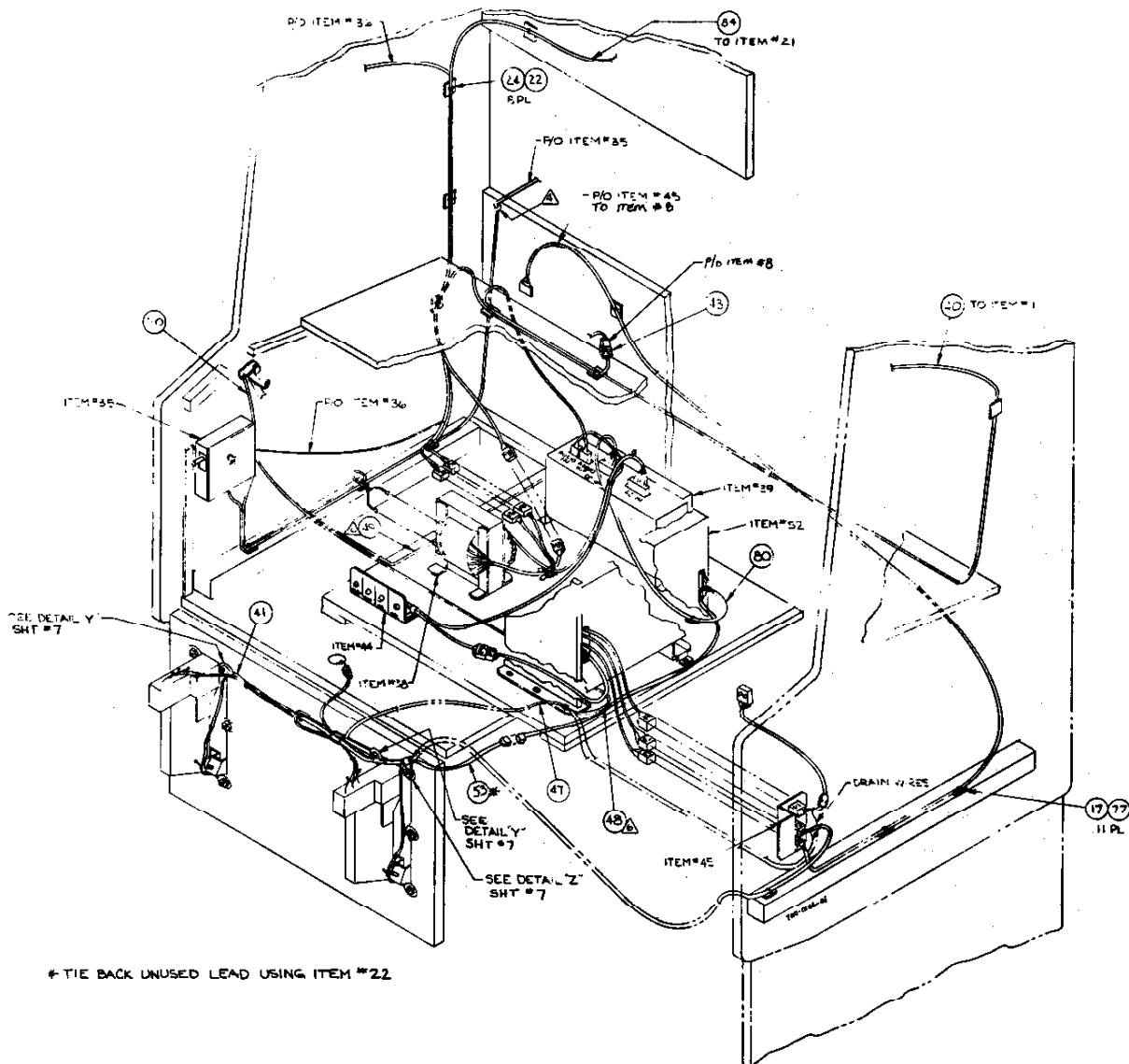

<u>ITEM NO.</u>	<u>PART NO.</u>	<u>QTY REQD.</u>	<u>DESCRIPTION</u>
1	130-0020	1	Speaker Game 6 x 9, 10W
2	130-0002	1	Speaker Cover 6 x 9
3	140-0021	1	Cover J-Box
4	140-0055	1	Cabinet Universal Upright
5			
6	220-0167	2	Lock Coin Mech Door (& Back)
7	220-0178	2	Draw Catch
8	420-0656	1	Decal Self-Test Instructions
9	420-0636	1	Tag, Extra Value
10	250-0038	1	Molding Strip
11	250-0048	1	Clip Switch
12	250-0458	1	Saddle G-80 Cage
13	250-0481	1	Strike Plate
14	250-0492	1	Molding Logo Panel
15	250-0497	2	Clamp Component Board
16	420-0800		Decal, Dipswitch
17	280-0345	11	Tie Wrap, Screw Mounted
18	253-0272	1	Panel Logo
19	253-0222	2	Coin Receptacle
20	253-0228	1	Monitor Panel Clear
21	260-0001	1	Fan Axial Cooling
22	280-0005	30	Cable Tie
23	280-0324	2	Cable Clamp Nylon
24	280-0327	8	Base Tie Wrap
25	280-0360	2	Washer Lock, Lock
26	280-0359	2	Elec. Crimp Sleeve
27	390-0019	1	Lamp Fluor
28			
29	420-0030	1	Decal Caution 115V
30			
31	420-0796	1	Graphic Interior

<u>ITEM NO.</u>	<u>PART NO.</u>	<u>QTY REQD.</u>	<u>DESCRIPTION</u>
32	420-0795	1	Manual
33	420-0568	1	Decal FCC
34	420-0624	1	Light Baffle
35	800-0145-01	1	Assy AC Junction Box
36	800-0147	1	Assy Fluor Lamp 2
37	800-0178	1	Assy Harn Power
38	800-0190	1	Assy XFMR EMI
39	800-0191	1	Assy Game Power Supply G-80
40	800-0192	1	Assy Speaker Harn G-80
41	800-0232	1	Assy Harn Gnd Intf
42	200-0025	1	19" Electrohome X-YClr Monitor
43	800-0255	1	Assy Harn AC Monitor Intf X-Y
44	800-0277	1	Assy Vol Control Block
45	800-0279	1	Assy Conn Bracket
46	800-0280	1	Assy Coin Counter
47	800-0284	1	Assy Harn Gnd Coin Mech Univ.
48	800-0285	1	Assy Harn Gnd Game Elec Univ.
49	800-0286	1	Assy Harn Gnd G-80 PS Univ.
50	800-0290	1	Assy Gnd Strap Cont Pnl Univ.
51	800-3265	1	Assy Cont Pnl
52	800-3267	1	Assy Game Electronics
53	420-0798	1	Decal Game Instructions
54	281-0014-28	4	Scr Oval Phil Mach #8-32 x 1.750 Black
55	283-0024-00	4	Nut Hex Mach #8-32
56	284-0004-00	4	Washer Flt Std O.D. Steel #8
57	284-0034-00	6	Washer Lock Split Steel #8
58	284-0016-00	25	Washer Flt Small OD Stl #10
59	800-0276	1	Assy Harn Coin Mech
60	282-0005-20	11	Bolt Carriage HD Mach #10-24 x 1.250
61	284-0036-00	45	Washer Lock Split Stl #10
62	283-0025-00	17	Nut Hex, Mach #10-24
63	282-0005-24	3	Bolt Carriage HD Mach #10-24 x 1.50

<u>ITEM NO.</u>	<u>PART NO.</u>	<u>QTY REQD.</u>	<u>DESCRIPTION</u>
64	281-0044-08	2	Scr PN HD Phil S/M Type A/AB # 8-15 x .500
65	281-0052-08	4	Scr 82 <sup>0</sup> Flt HD Phil S/M Type A/AB #6-18 x .500
66	282-0017-24	8	Bolt Hex HD Mach #1/4-20 x 1.500
67	286-0044-12	4	Scr. PN HD Phil S/M Type A/AB Blk #8-15 x .750
68	282-0017-16	2	Bolt Hex HD Mach #1/4-20 x 1.000
69	284-0027-20	14	Washer Flat 1.250 O.D. Stl #1/4
70	283-0007-00	4	Nut Hex Self Locking Mach #1/4-20
71	284-0037-00	10	Washer Lock Split Stl #1/4
72	281-0042-32	6	Scr PN HD Phil S/M Type A/AB #6-18 x 2.000
73	284-0002-00	4	Washer Flt Std OD Stl #6
74			
75	281-0045-12	27	Scr PN HD Phil S/M Type A/AB #10-12 x .750
76	284-0006-00	12	Washer Flt #10 x 3/4
77	281-0074-12	11	Scr Flt HD Phil #8-15 x .75 LG 82 <sup>0</sup>
78	283-0015-00	1	Wing Mach #10-24
79			
80	800-0314	1	Assy Harn Power
81	800-0315	1	Assy Harn C/M Light
82	800-0321	1	Assy Harn C/M Univ.
83	220-0194	1	Coin Mech W/Light
84	800-0322	1	Assy Cord Fan

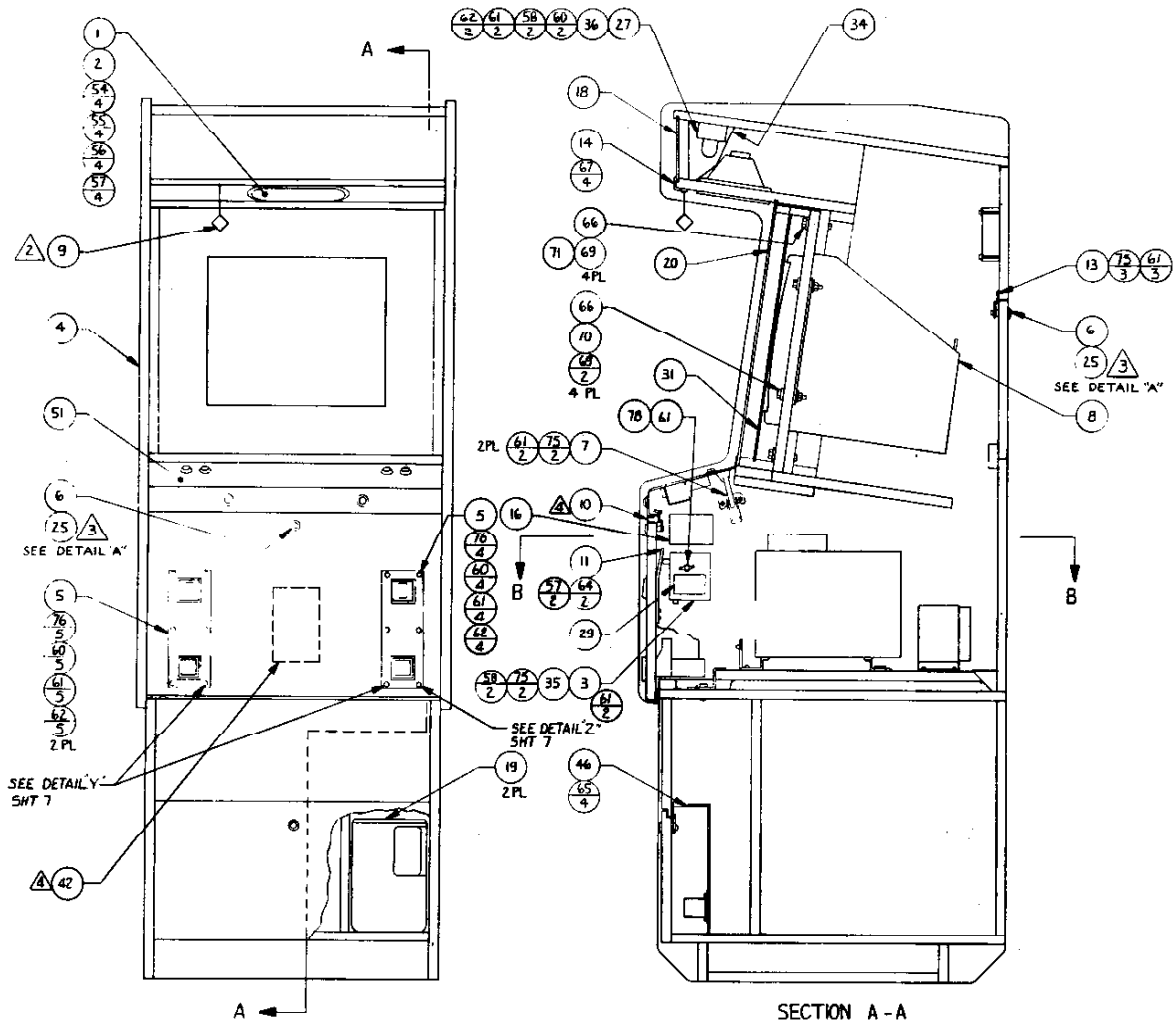

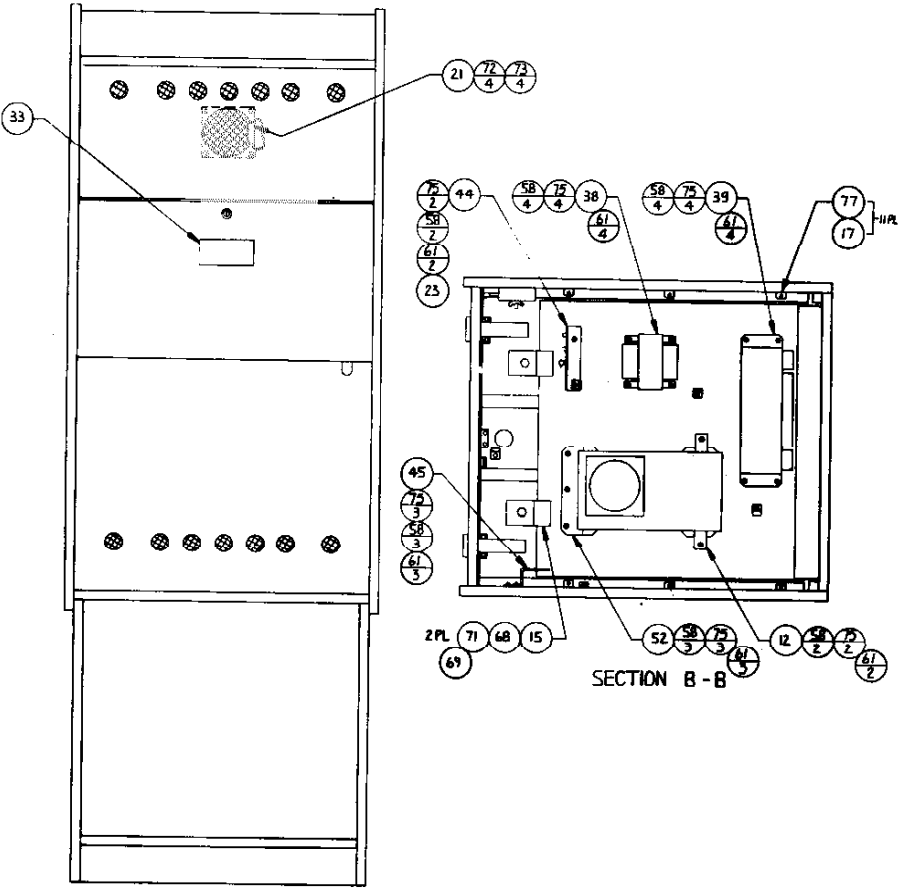

TOP ASSEMBLY

700-0106-00

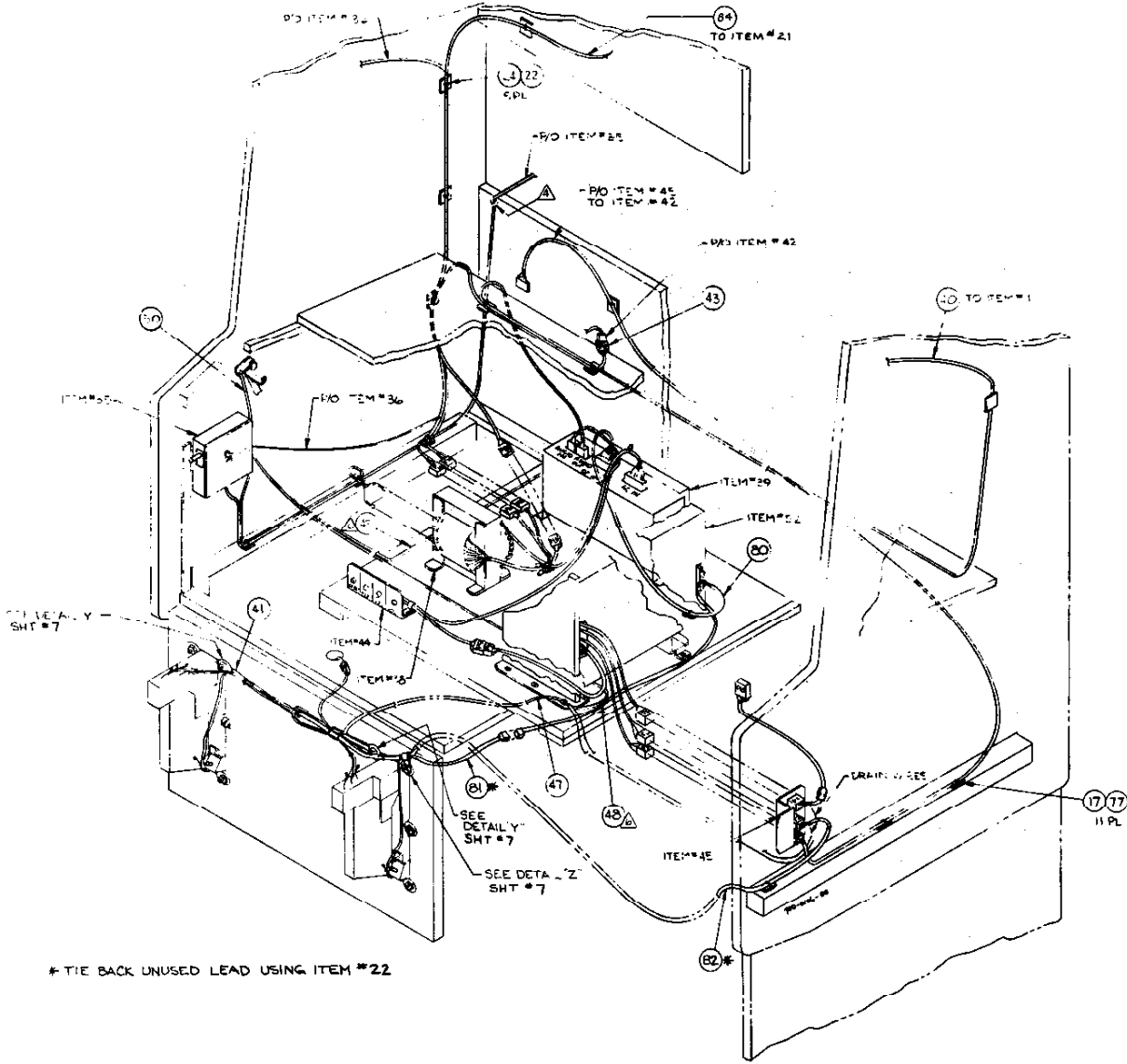

## CONTROL PANEL ASSEMBLY

DRAWING NUMBER 800-3265

<u>ITEM NO.</u>	<u>PART NO.</u>	<u>QTY REQD.</u>	<u>DESCRIPTION</u>
1	250-0538	1	Subpanel Metal
2	253-0273-00	1	Graphic Control Panel
3	800-0390	1	Assy, Rotary Control
4	240-0111	2	Button, Plunger, Blue
5	240-0006	2	Button, Plunger, Red
6	240-0009	2	Button, Plunger, Yellow
7			
8	510-0064	6	Switch Pushbutton Metal Panel
9	280-0329	6	1/2 IN - 13 Hex Pal Nut
10	282-0005-12	4	Bolt 10-24 x .750 Carriage Mach
11	284-0016-08	4	Washer, Flat #10-.220 I.D. x .500 O.D.
12	284-0036	4	Washer Lock Split #10
13	283-0005	4	Nut 10-24 Hex Self Locking
14	800-0374	1	Interface Assy Single Player Control Panel
15			
16	281-0002-10	4	Screw 6-32 x 5/8 IN Pan HD Mach
17	284-0012-06	4	Washer, Flat #6-.150 I.D. x .375 O.D.
18	800-3248	1	Control Panel Harness Assy
19	280-0327	2	Base Tie Wrap
20	280-0005	8	Cable Tie
21	250-0565-00	1	Knob-Modified Rotary Control



# CONTROL PANEL COMPLETE ASSEMBLY

800-3265

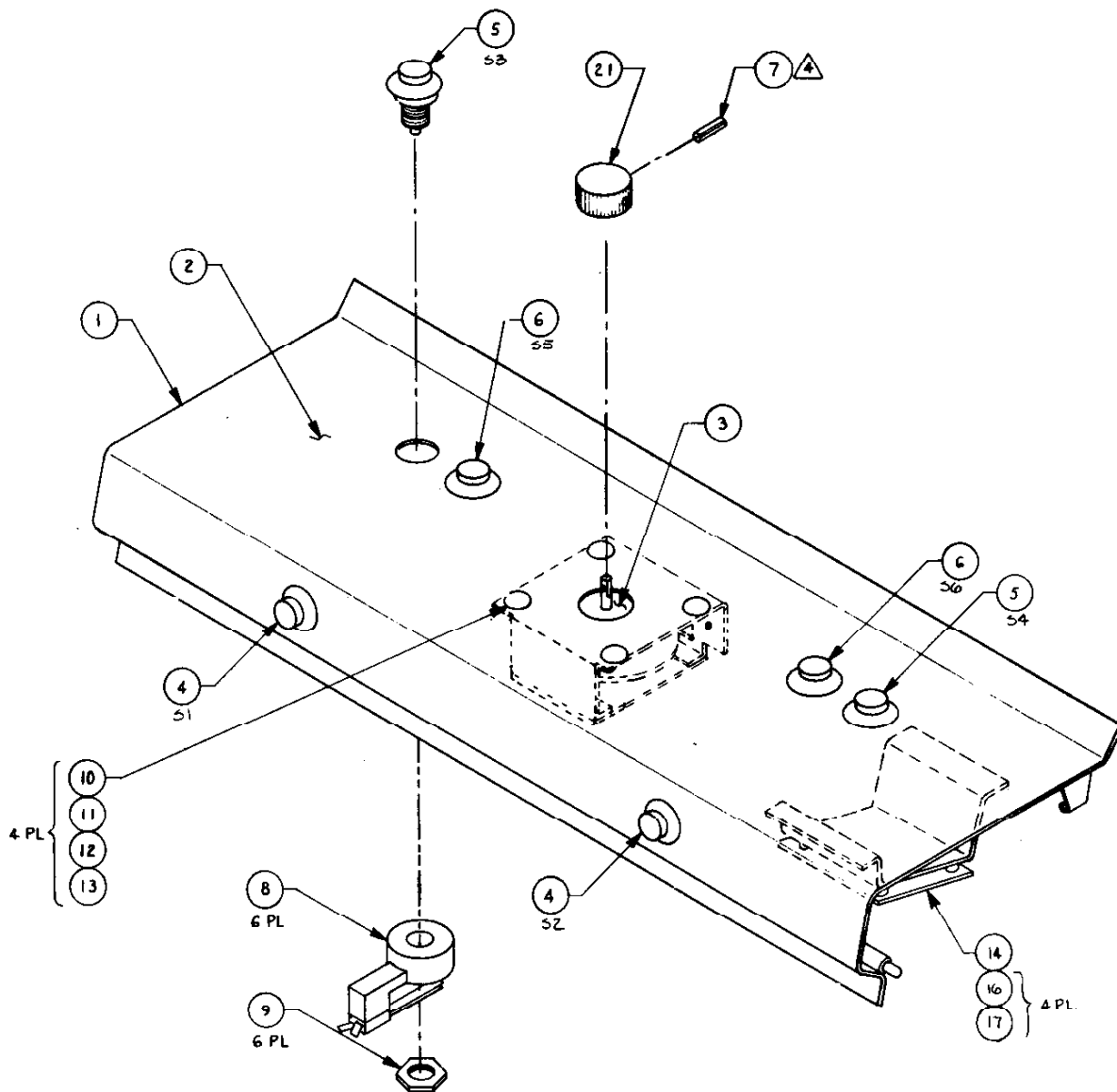

# CONTROL PANEL COMPLETE ASSEMBLY

800-3265

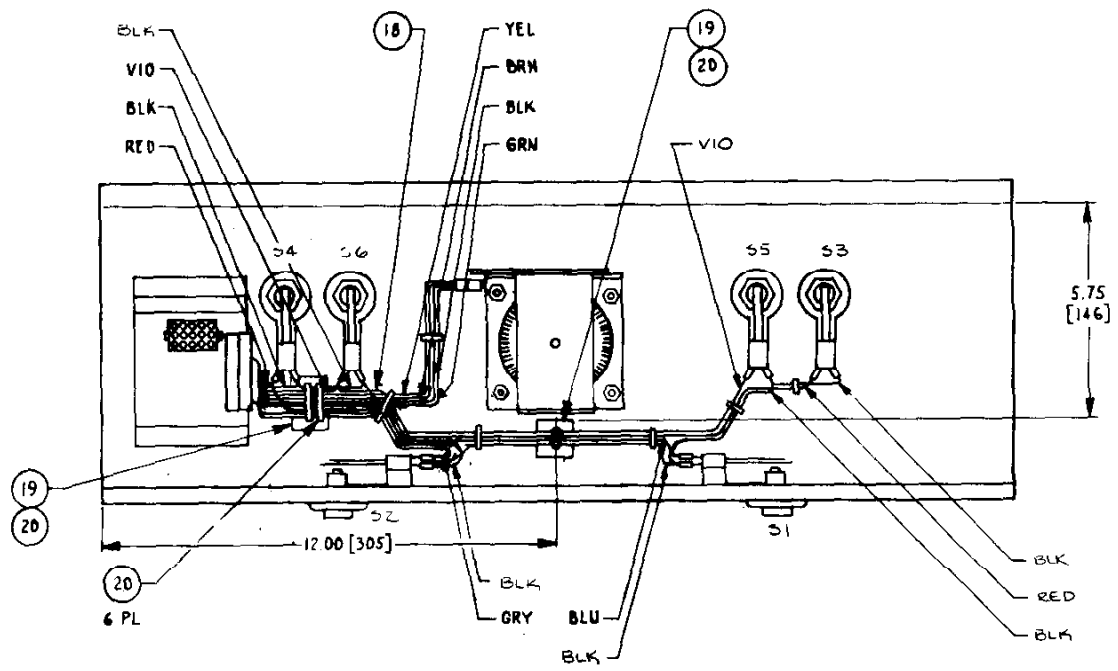

## COMPONENT SHELF ASSEMBLY

DRAWING NUMBER 800-3266

<u>ITEM NO.</u>	<u>PART NO.</u>	<u>QTY</u> <u>REQD.</u>	<u>DESCRIPTION</u>
1	250-0458-00	1	Saddle G-80 Cage
2	252-0142-00	1	Component Shelf UP. CAB.
3	280-0324-00	1	Cable Clamp Nylon
4	281-0045-12	15	SCR 10-12 x 3/4" PN HD Type A/AB
5	284-0016-08	15	Washer Flt #10 Small OD 1/2"
6	284-0036-00	15	Washer Lock Split #10
7	280-0005-00	5	Cable Tie
8	800-0190-00	1	Assy XFMR EMI
9	800-0191-00	1	Assy Game Pwr Supply G-80
10	800-0277-00	1	Assy Volume Control Block
11	800-0285-00	1	Assy Harn Gnd Game Elec.
12	800-0286-00	1	Assy Harn Gnd Pwr Supply
13	800-0314-00	1	Assy Harn Pwr
14	800-3267-00	1	Game Elec. Assy
15	280-0475-00	12	Staple

# COMPONENT SHELF ASSEMBLY

800-3266

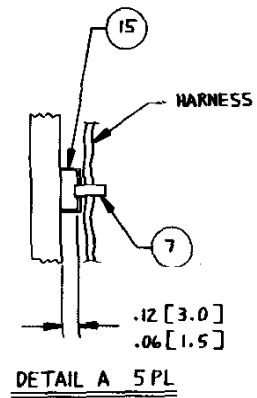
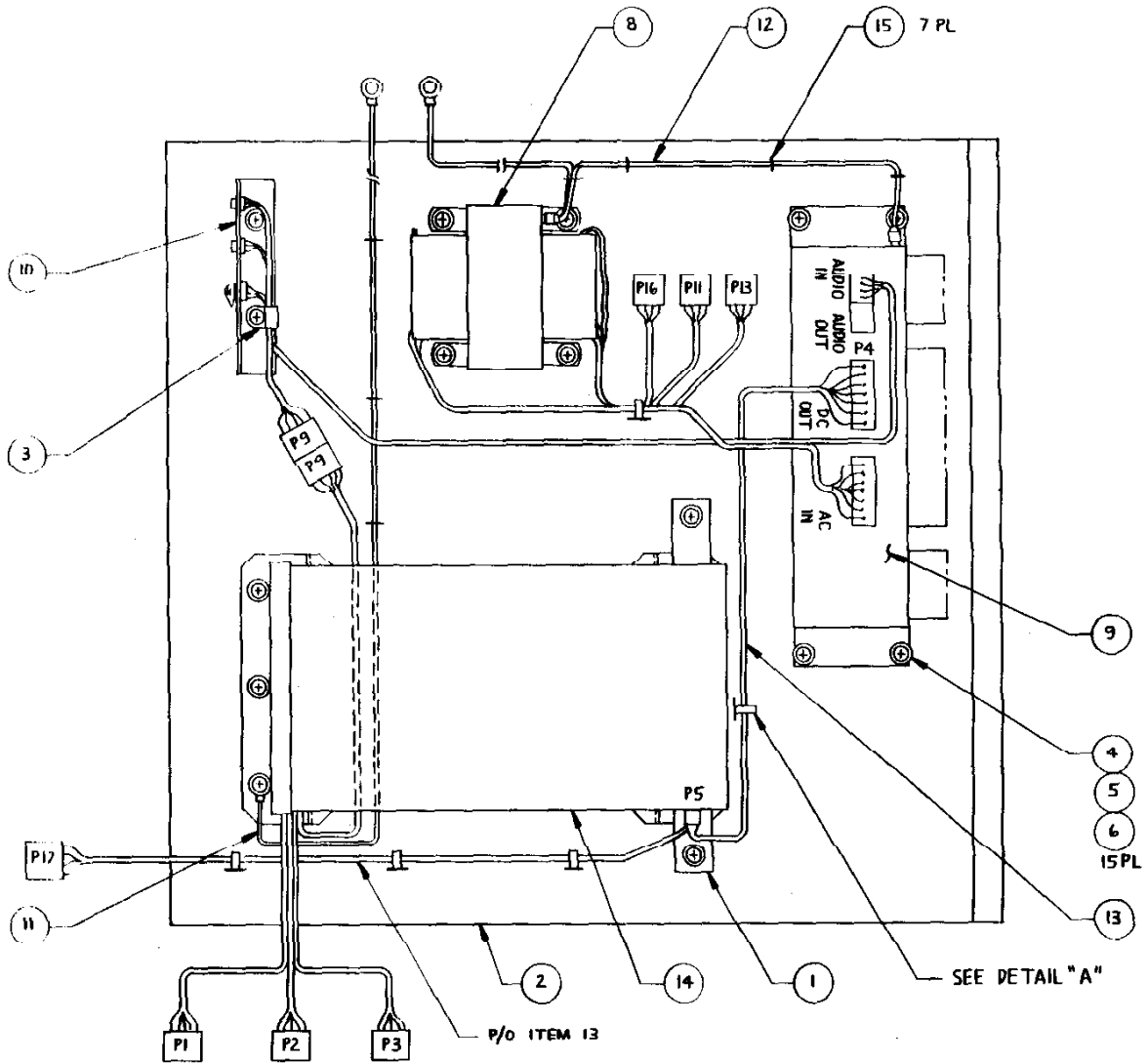

<u>ITEM NO.</u>	<u>PART NO.</u>	<u>QTY</u> <u>REQD.</u>	<u>DESCRIPTION</u>
1	420-0560-00	1	Decal Test Button
2	420-0801-00	1	Decal Electronics TAC/SCAN 7
3	600-0089-00	1	Cable X-Y Interface
✓ 4	800-0161-00	1	Assy X-Y Timing PCB
✓ 5	800-0163-00	1	Assy X-Y Control PCB
6	800-0282-00	1	Assy Harn Video X-Y Intf
7	800-0296-00	1	Assy G-80 Gage Univ
8	800-0378-00	1	CPU Master Harn Assy
9	800-3268-00	1	Assy CPU PCB
10	800-3269-00	1	Assy 2716 Prom PCB
11	800-3270-00	1	Sound Board Assy
12	800-0302-00	1	Assy Jumper Plug

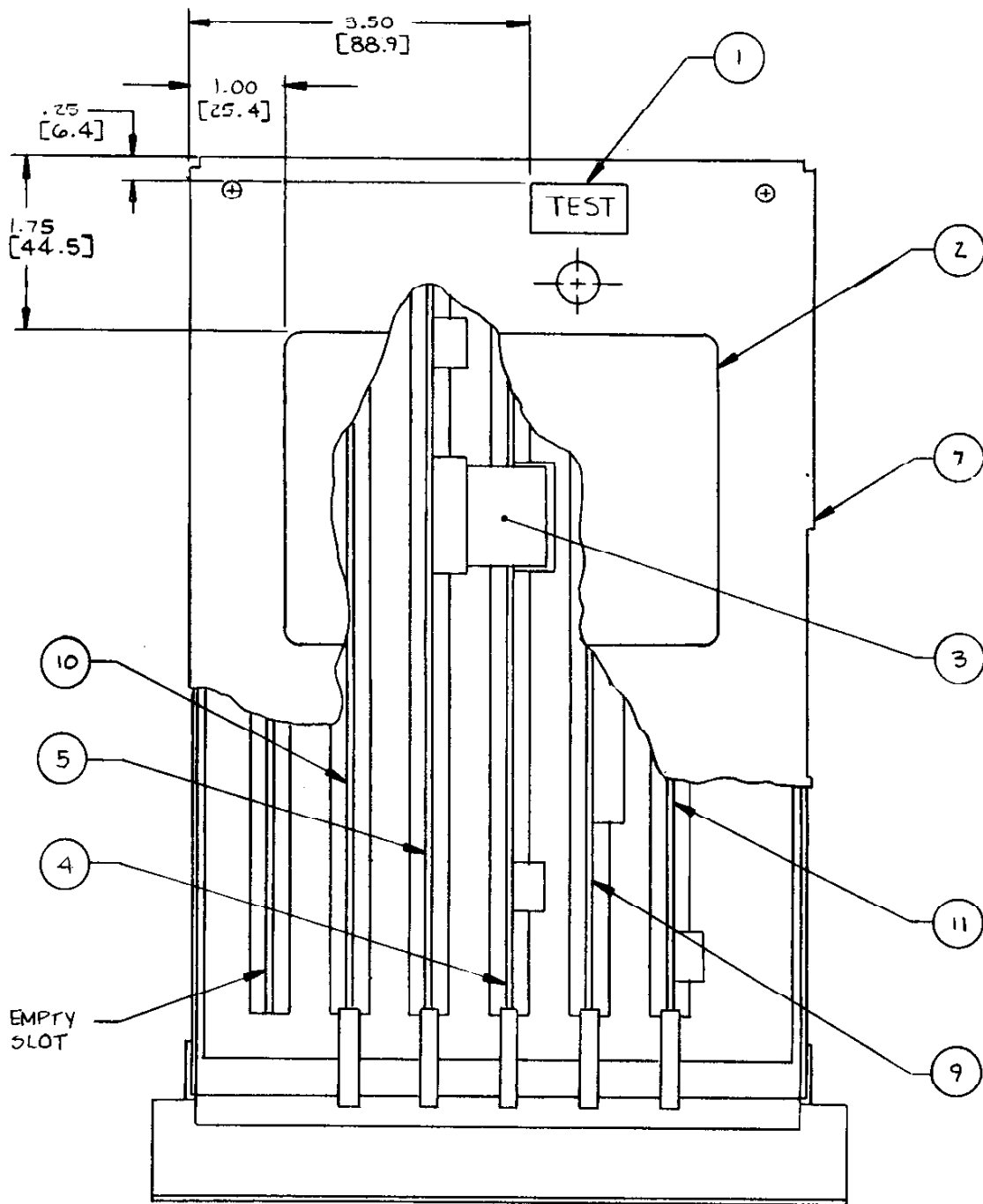

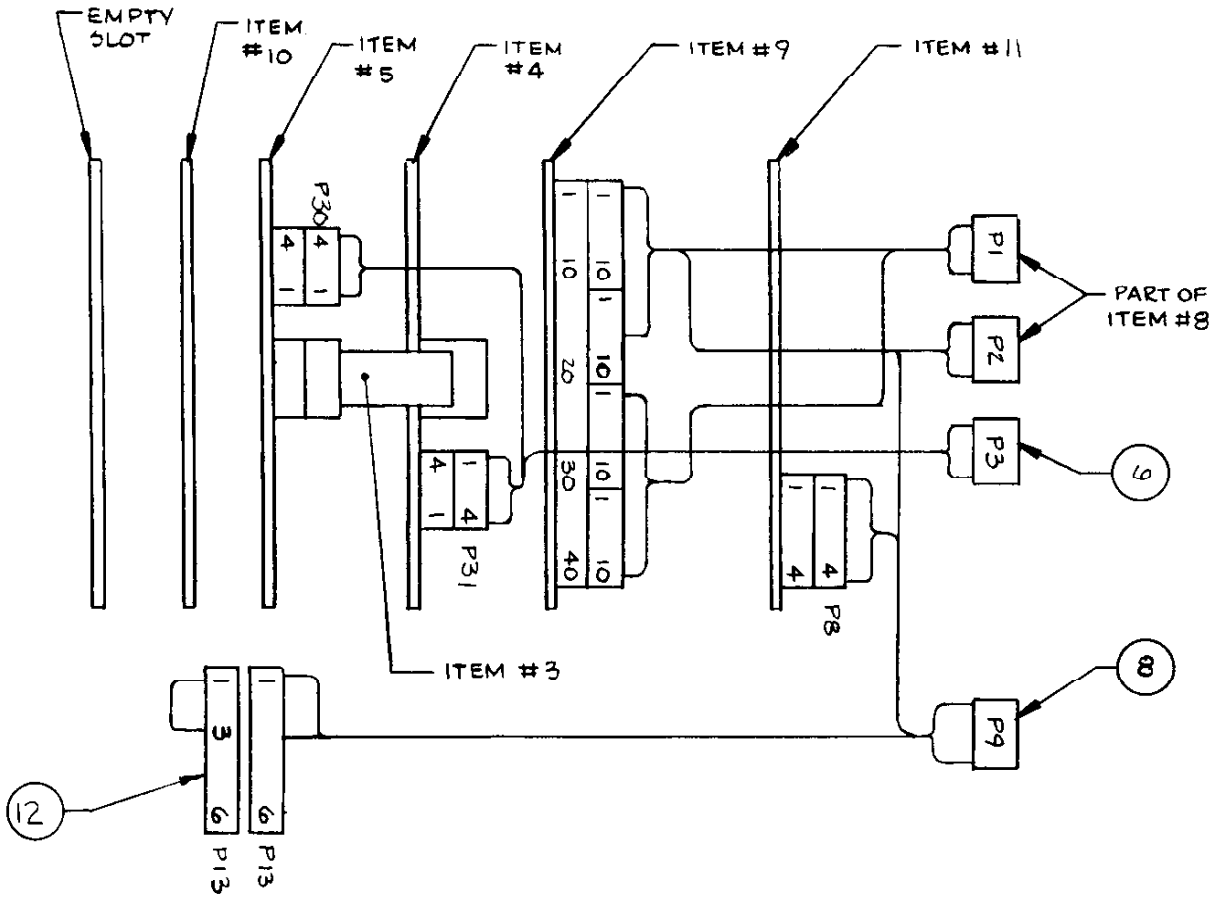

## SINGLE PLAYER CONTROL PANEL INTERFACE ASSEMBLY

DRAWING NUMBER 800-0374

<u>ITEM NO.</u>	<u>PART NO.</u>	<u>QTY</u> <u>REQD.</u>	<u>DESCRIPTION</u>	<u>REF DES.</u>
1	150-0088	1	Cap E 10 uf 25V RDL	C3
2	151-0058	2	Cap .01 uf 16V AX	C1, C2
3	151-0059	1	Cap .001 16V AX	C4
4	170-0258	1	PC Board	
5	212-0024	1	Conn 12 Pin M RTA PLRZD	P30
6	212-0156	1	Conn Header 15 Pin	P10
7	314-0055	2	IC 74LS244	U2, U3
8	314-0062	1	IC 74LS74	U5
9	314-0075	1	IC 74LS39	U1
10	314-0085	1	IC 74LS14	U4
11	471-0102	3	Res 1K Ohm 1/2W 5%	R1-R3



SINGLE PLAYER CONTROL PANEL INTERFACE ASSEMBLY 800-0374

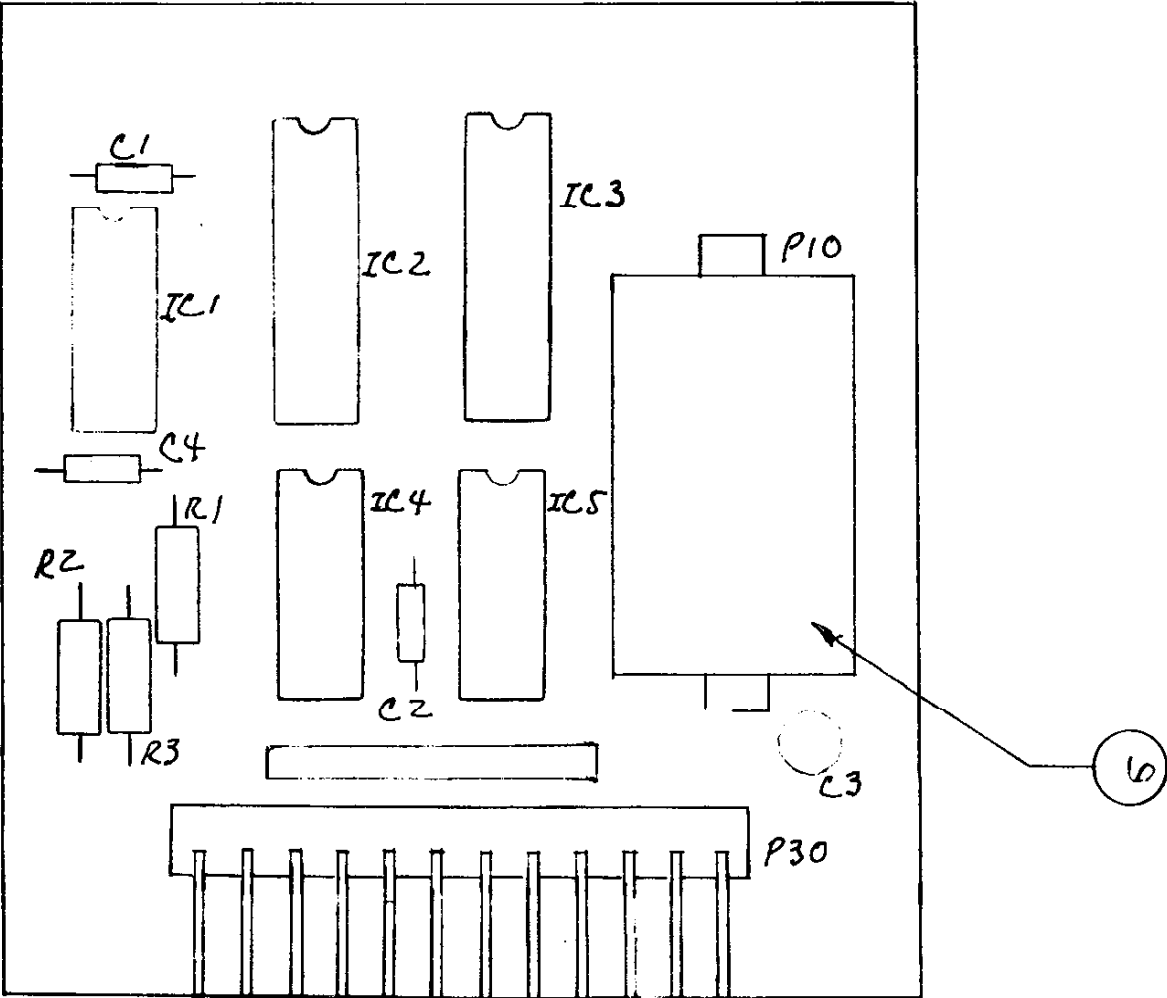

ROTARY ASSEMBLY INTERFACE

DRAWING NUMBER 800-0382

ITEM NO.	PART NO.	QTY REQD	DESCRIPTION	REF DES
1	170-0160	1	PC Board	
2	212-0081	1	Conn M 4 Pin RTA PLRZD	P1
3	285-0001-04	4	Rivet .125 Dia X .25 Lg	
4	370-0006	2	Opto Electric Encoder XSTR	DS1, DS2
5	470-0101	1	Res 100 Ohm 1/4W 5%	R1

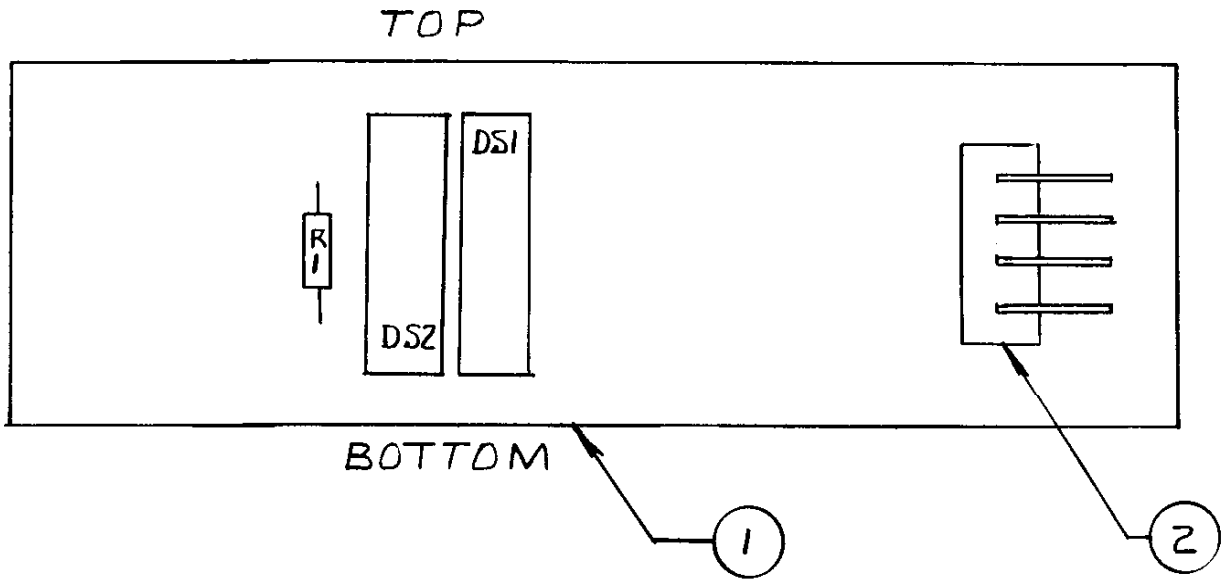

DEVICE NUMBER	ORIENTATION MARK	LOCATION
H21A2	NOTCH	FACING BOTTOM
H21A3	NOTCH	FACING BOTTOM
K-2133	DOT	FACING TOP
K-2133A	DOT	FACING TOP

ROTARY CONTROL ASSEMBLY

DRAWING NUMBER 800-0390

ITEM NO.	PART NO.	QTY REQD	DESCRIPTION
1	281-0031-04	2	Scr #4-40 X 1/4" PN HD Thd Forming
2	284-0011-05	2	Wshr #4 F1, SM OD, St1
3	800-0382	1	Rotary Interface Assy
4	800-0383	1	Rotary Bracket Assy

ROTARY CONTROL ASSEMBLY

800-0390

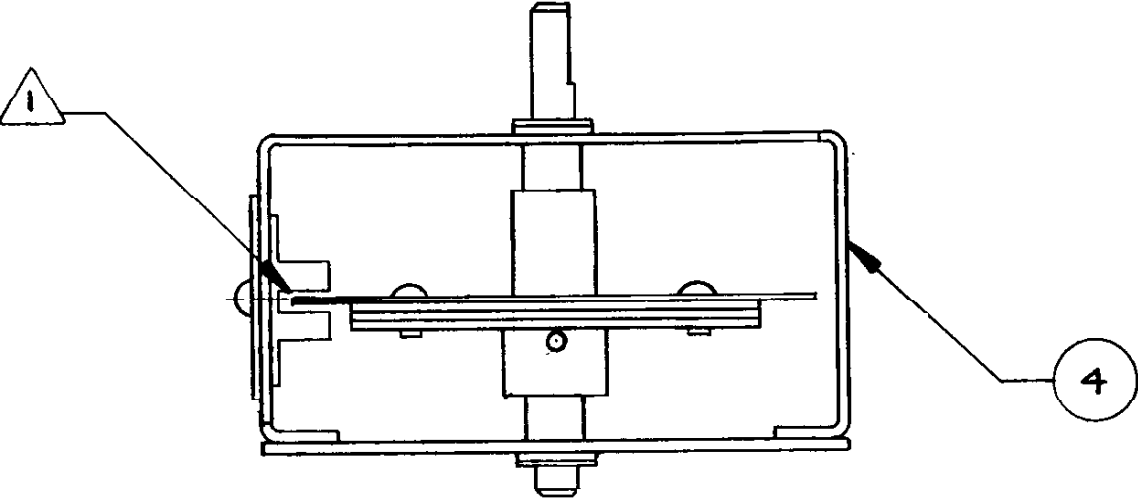
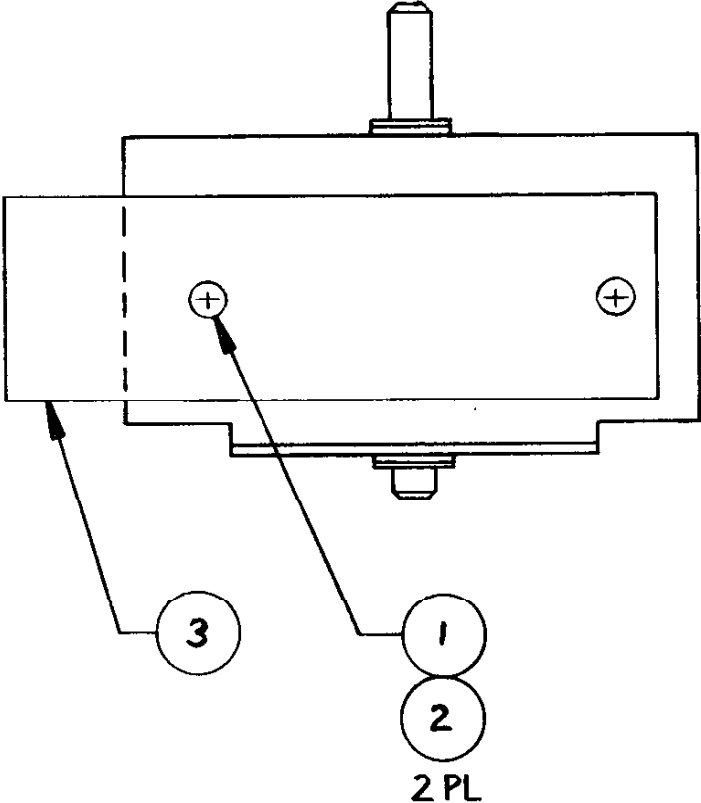

FLUORESCENT LAMP 2 ASSEMBLY  
FLUORESCENT LAMP 2 ASSEMBLY

DRAWING NUMBER 800-0147-00  
DRAWING NUMBER 800-0147-01

<u>ITEM NO.</u>	<u>PART NO.</u>	<u>QTY REQD.</u>		<u>DESCRIPTION</u>
		<u>-00</u>	<u>-01</u>	
1	211-0041	2	2	Conn Pin Amp
2	211-0044	1	1	Conn Cap Amp 2 Pin
3				
4	211-0166-00	1	-	Conn Crimp Ring #10
5				
6	280-0361	-	1	BSHG STR RLF AC Cord
7	280-0362	-	2	Elec CRP SL 24-18 AWG
8				
9	281-0002-06	1	1	SCR #6-32 x 3/8" PN HD Mach
10				
11				
12				
13				
14	284-0002-00	-	1	Washer Flat STD O.D. #6
15				
16				
17	390-0083	1	-	Fluor Lamp Fxt 18 IN
18	390-0117	-	1	Fluor Lamp Fxt 18 IN U.L.
19				
20				
21				
22				
23	600-0079-00	1	5.9'	CA 2 Cond Zip Cord

# FLOURESCENT LAMP ASSEMBLY

800-0147

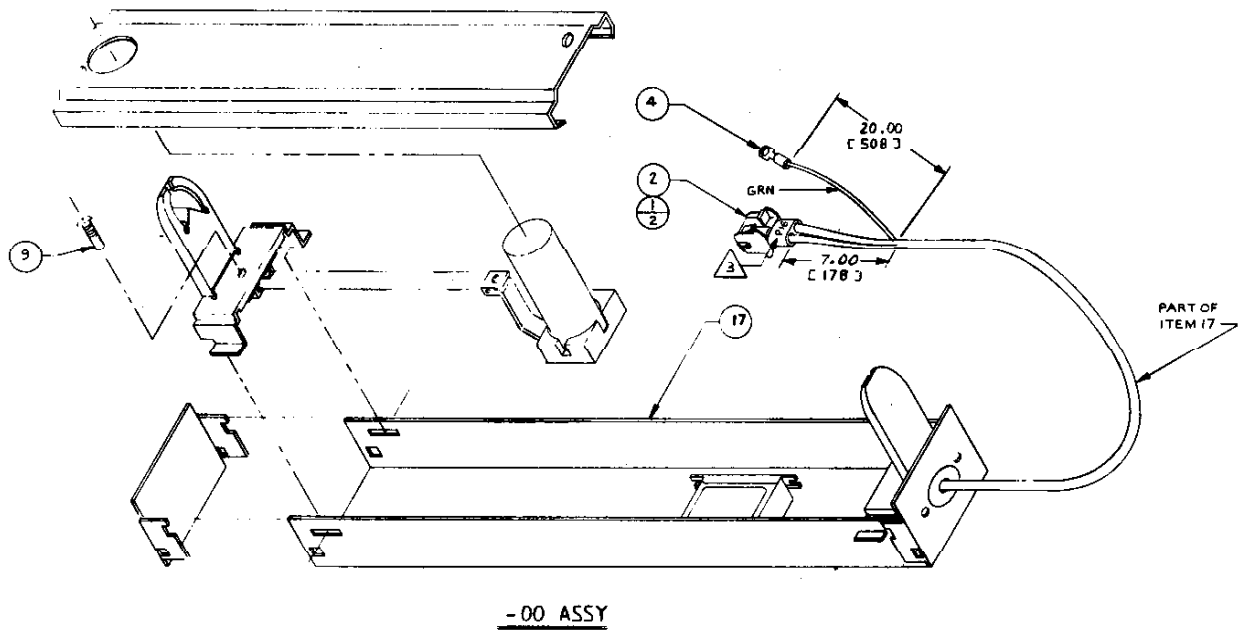

# FLUORESCENT LAMP 2 ASSEMBLY

800-0147

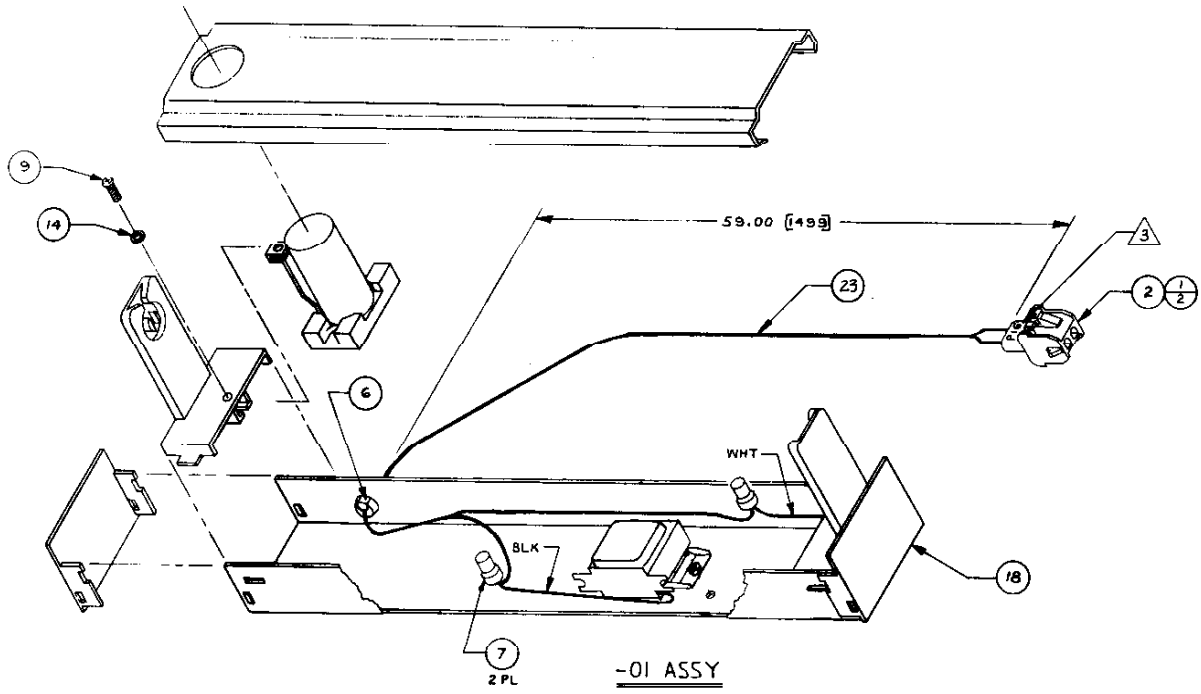



## VOL CONTROL BLOCK UNIV ASSEMBLY

DRAWING NUMBER 800-0277

<u>ITEM NO.</u>	<u>PART NO.</u>	<u>QTY</u> <u>REQD.</u>	<u>DESCRIPTION</u>
1	240-0001-00	1	Knob Volume Control
2	250-0462-00	1	Brkt Volume Control
3	285-0001-04	4	Rvt .125 Dia x .250 LG MDRL Pull, Dome HD, AL
4	420-0623-00	1	Decal Oper Cont Blk
5	475-0007-00	1	Pot 10K Car PNLMT
6	510-0051-00	2	SW Pushbutton Slide
7	800-0402-00	1	Harn Vol Control Blk Univ

# VOLUME CONTROL BLOCK UNIVERSAL ASSEMBLY

800-0277

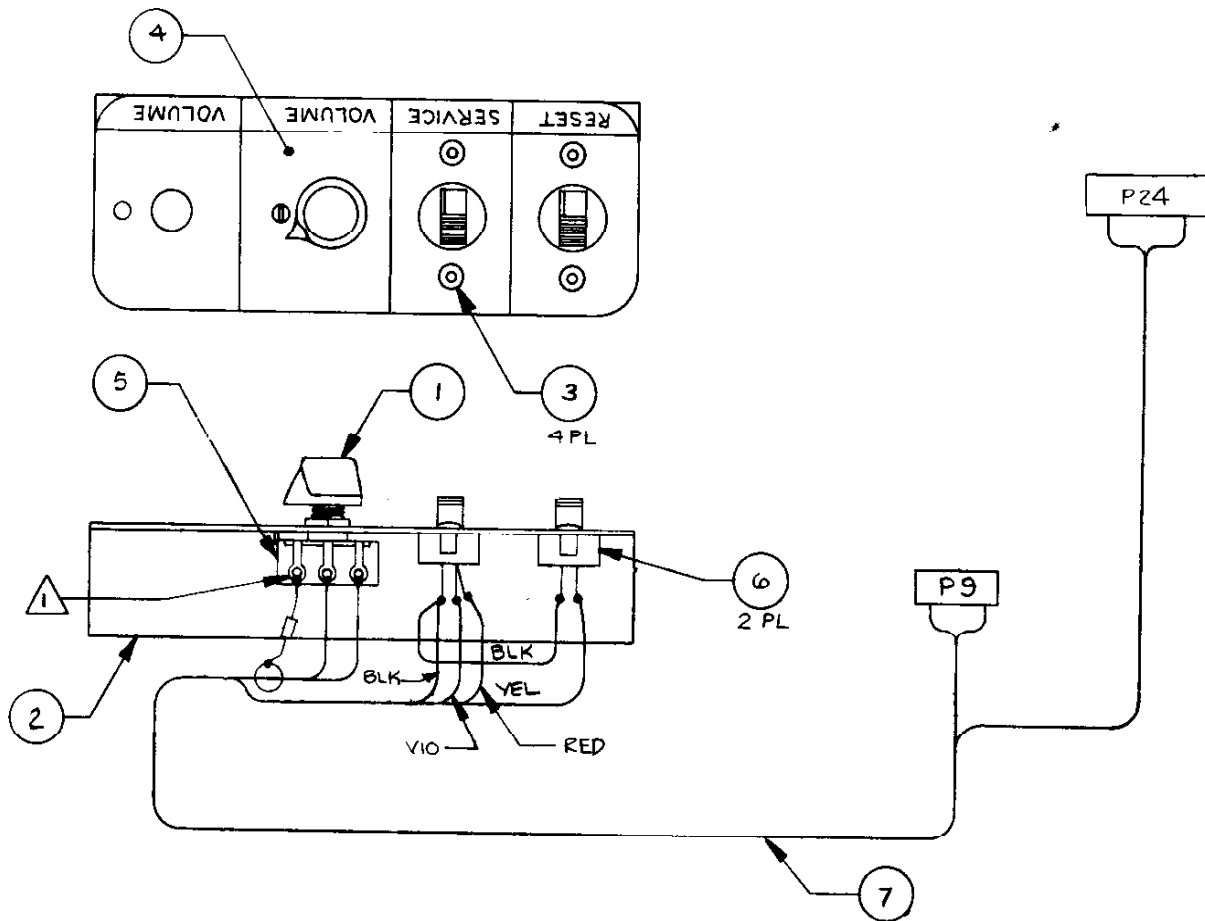

## COIN COUNTER ASSEMBLY

DRAWING NUMBER 800-0280

<u>ITEM NO.</u>	<u>PART NO.</u>	<u>QTY REQD.</u>	<u>DESCRIPTION</u>
1	220-0008	1	Digital Counter, 6 volts
2	250-0496	1	Coin Counter Bracket
3	281-0002-08	4	Pan Head Phillips screw, 6-32 x 1/2" machine
4	284-0002-00	4	Flat Washer, #6
5	284-0032-00	4	Split Lock Washer, #6
6	283-0022-00	4	Hex Nut, #6-32

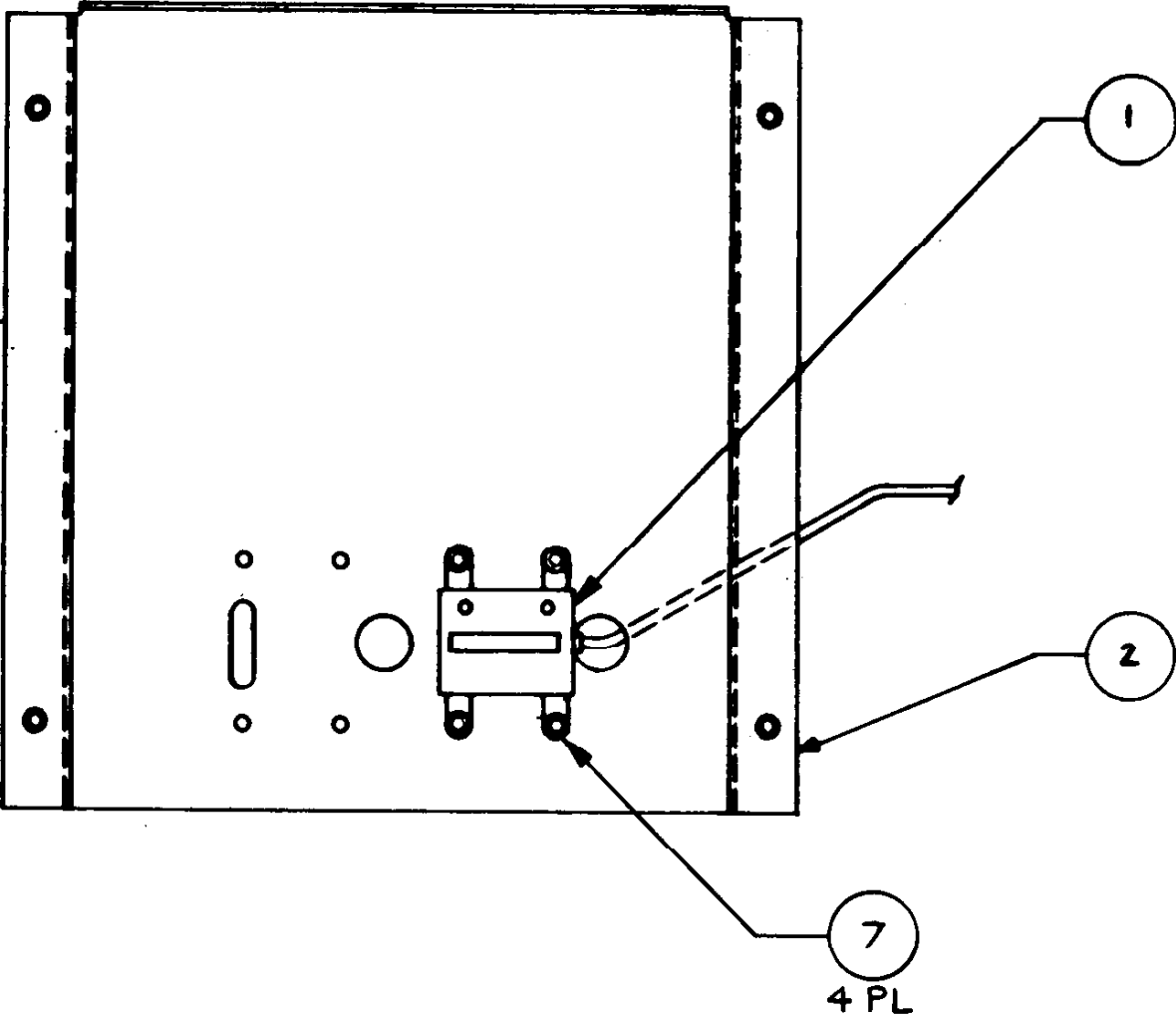

FAN CABINET #2 ASSEMBLY

DRAWING NUMBER 800-0297

<u>ITEM NO.</u>	<u>PART NO.</u>	<u>QTY</u> <u>REQD.</u>	<u>DESCRIPTION</u>
1	260-0001	1	Axial Cooling Fan, 110 VAC
2	211-0078	2	Conn Term Pin 20-14 AWG
3	280-0005	7	Cable Tie
4	211-0044	1	Conn Cap Amp 2 Pin

# FAN CABINET #2 ASSEMBLY

800-0297

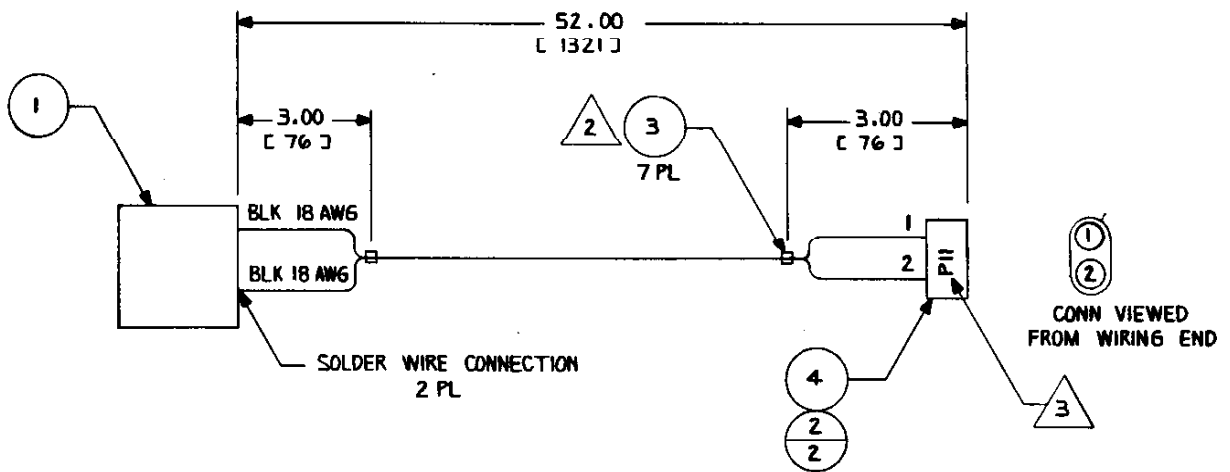

A.C. JUNCTION BOX ASSEMBLY  
A.C. JUNCTION BOX ASSEMBLY  
A.C. JUNCTION BOX ASSEMBLY

DRAWING NUMBER 800-0145-00  
DRAWING NUMBER 800-0145-01  
DRAWING NUMBER 800-0145-02

ITEM NO.	PART NO.	QTY REQD.			DESCRIPTION
		-00	-01	-02	
1	140-0020	1	1	1	Junction Box Metal
2	211-0165	2	2	2	Conn Quick Fem Fully Insl. .250 x .032 (AWG 18-22)
3	211-0164	4	4	4	Conn Quick Fem Fully Insl. .187 x .020 (AWG 18-22)
4					
5	280-0361	1	1	1	Bushing S/Rel AC Cord
6	270-0001	1	1	1	Filter EMI
7	280-0007	1	1	1	Bushing S/Rel 1/2
8	280-0362	4	4	4	Electric Crimp Sleeve AWG 24-18
9	420-0598	1	-	-	Decal 2 Amp Fuse
10	510-0013	1	1	1	Switch SPDT Cherry
11	514-0001	1	-	-	Fuse 2 Amp 250V S.B.
12	514-0005	1	1	1	Holder Fuse
13	600-0001	1	1	1	Cord Line 3 Cond.
14					
15	600-0079	2 Ft.	2 Ft.	2 Ft.	Cord Line Zip
16	280-0005	2	2	2	Cable Tie
17	218-0002-10	2	2	2	SCR PN HD Phil #6-32 x .625 Mach
18	283-0022-00	2	2	2	Nut Hex HD #6-32 Mach
19	284-0042-00	2	2	2	Washer Lock Int. Tooth #6
20	281-0004-12	1	1	1	SCR PN HD Phil #8-32 x .750 Mach
21	283-0024-00	2	2	2	Nut Hex HD #8-32 Mach
22	284-0044-00	1	1	1	Washer Lock Int. Tooth #8
23					
24	284-0007-00	1	1	1	Washer Flat STD O.D. #1/4
25	283-0025-00	1	1	1	Nut Hex HD #10-24 Mach
26	282-0005-28	1	1	1	Bolt Carriage #10-24 x 1.750 Mach
27	310-0016-16	1	1	1	Insul TGB .187 ID

A.C. JUNCTION BOX ASSEMBLY-Continued  
A.C. JUNCTION BOX ASSEMBLY-Continued  
A.C. JUNCTION BOX ASSEMBLY-Continued

DRAWING NUMBER 800-0145-00  
DRAWING NUMBER 800-0145-01  
DRAWING NUMBER 800-0145-02

<u>ITEM NO.</u>	<u>PART NO.</u>	<u>QTY REQD.</u>			<u>DESCRIPTION</u>
		<u>-00</u>	<u>-01</u>	<u>-02</u>	
28	284-0004-00	2	2	2	Washer Flat STD O.D. #8
29	420-0597	-	-	1	Decal 1 Amp Fuse
30	420-0634	-	1	-	Decal 5 Amp Fuse
31	514-0051	-	-	1	Fuse 1 Amp 250V
32	514-0053	-	1	-	Fuse 5 Amp S.B.



# AC JUNCTION BOX ASSEMBLY

800-0145

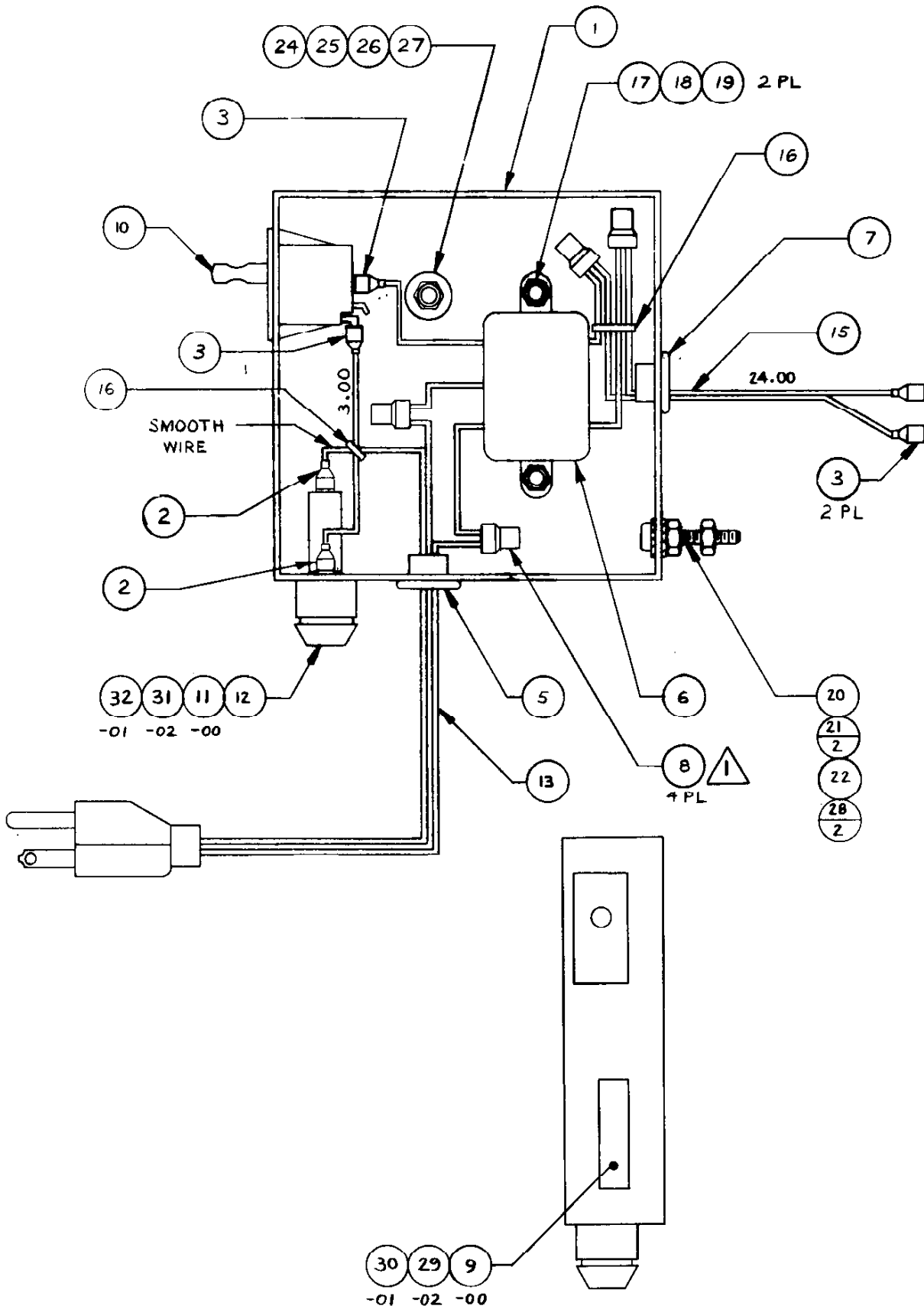

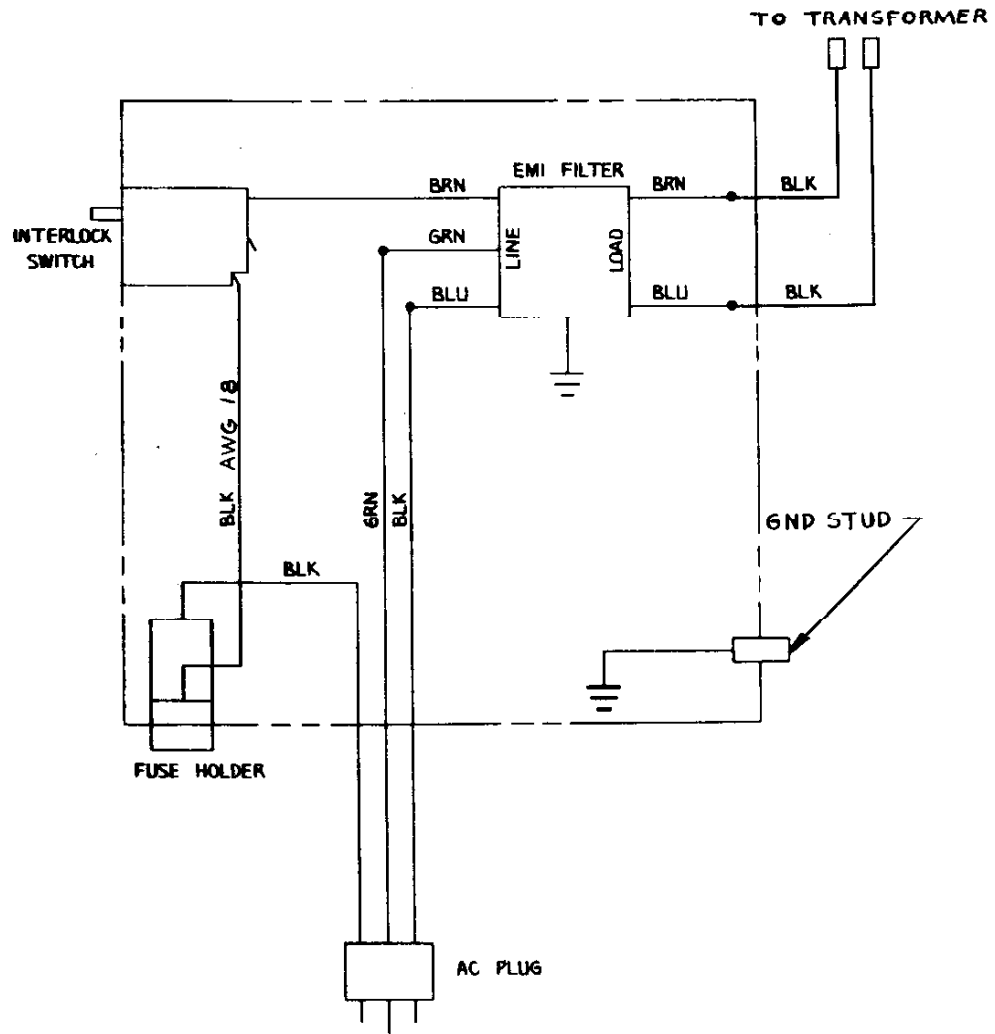

JUNCTION BOX SCHEMATIC

## TRANSFORMER EMI ASSEMBLY

DRAWING NUMBER 800-0190

<u>ITEM NO.</u>	<u>PART NO.</u>	<u>QTY REQD.</u>	<u>DESCRIPTION</u>
1	560-0055	1	G-80 Power Supply Transformer
2	212-0016	1	Connector, Female, 10 Pin
3	211-0005	9	Connector Crimp
4	211-0045	1	Connector Plug Amp, 6 Pin
5	211-0042	6	Connector Socket
6	211-0043	2	Connector Plug Amp, 2 Pin
7	600-0079	1 foot	Zip Cord
8	280-0005	4	Cable Tie
9		0.5 feet	Electric Strand Wire, Black, AWG 18
10	280-0359	3	Electric Crimp Sleeve
11	211-0077	4	Connector Terminal Socket, 20-14 AWG

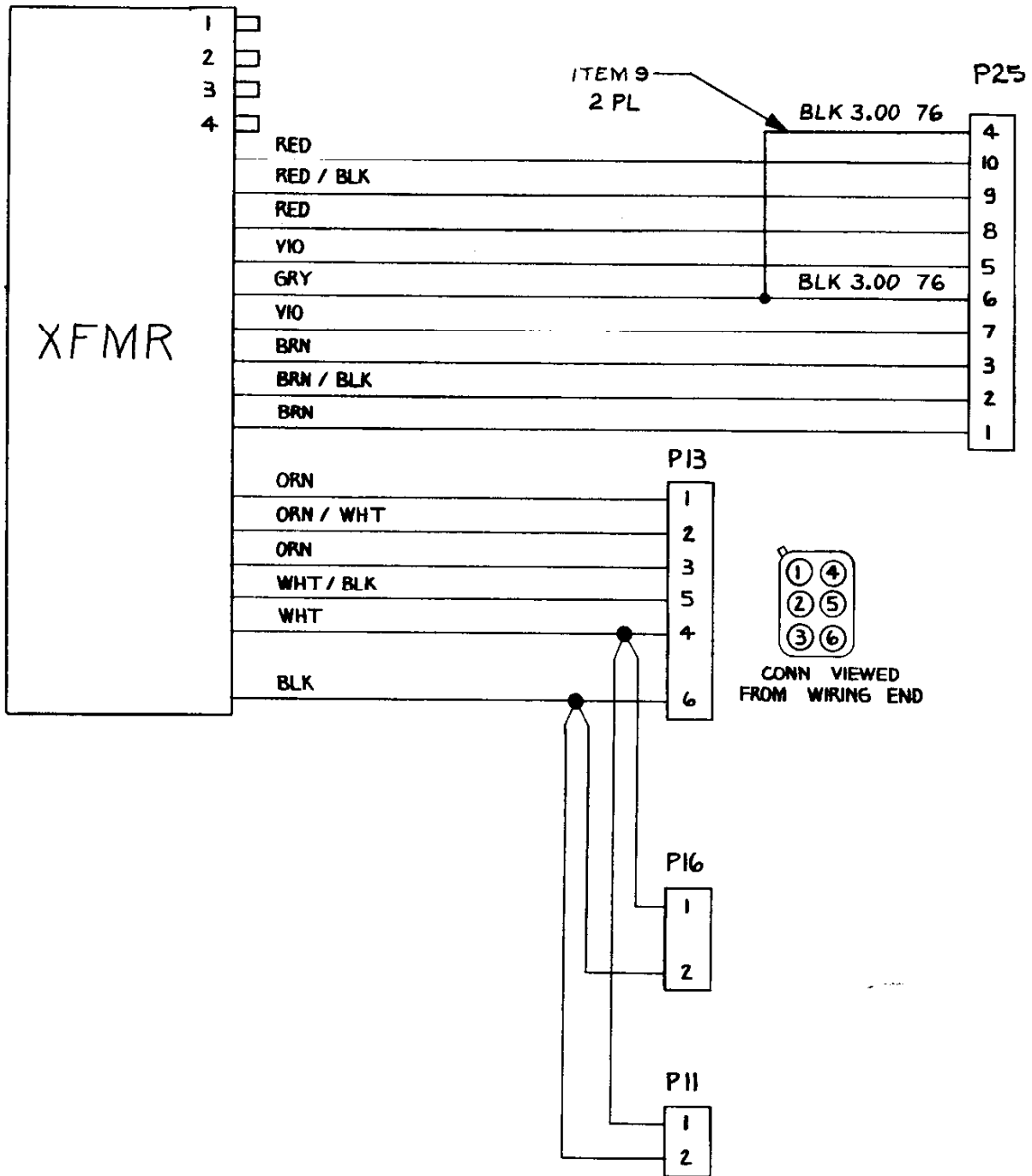

# EMI TRANSFORMER ASSEMBLY

800-0190

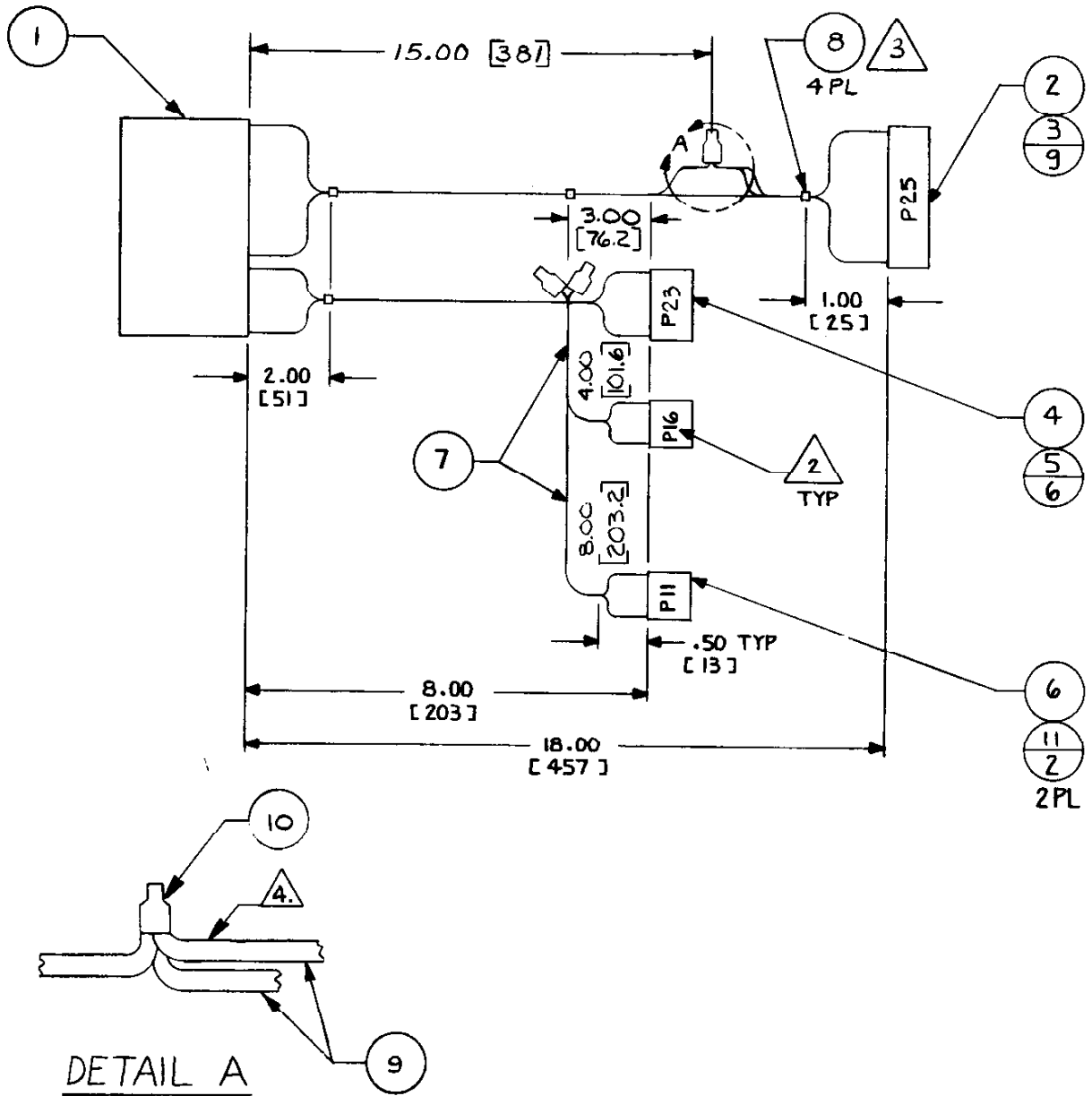

<u>PART NO.</u>	<u>DESCRIPTION</u>	<u>RES. DES.</u>
EHT SUPPLY ASSEMBLY		
SEMI-CONDUCTORS		
315-0118	EHT Control Circuit	IC900
481-0211	Zener Diode	ZD903, 904
481-0207	Rectifier 1A 1400V	D901
482-0062	Transistor 3906	Q901
482-0244	Transistor MPSU07	Q902
482-0030	Transistor 3904	Q903
TRANSFORMERS		
560-0062	Horiz. Buffer Trans.	T900
560-0073	Horiz. Output Trans.	T901
COILS		
180-0010	Horiz. Delay Choke	L900
CAPACITORS		
150-0007	4.7 uf 16V	C900
152-0053	0.22 uf 50V	C902
151-0109	2000 uf 50V	C903
150-0015	22 uf 16V	C904
151-0110	0.1 uf 100V	C906, 912
150-0222	0.022 uf 100V	C907
150-0010	100 uf 16V	C911
150-0221	High Current Cap	C914, 915
151-0113	47 uf 160V	C916
152-0027	0.047 uf 100V	C918
RESISTORS		
470-0103	10K 1/4W 5%	R900, 901, 906
460-0008	47K 1/4W 5%	R902
470-0154	150K 1/4W 5%	R904, 916, 934
470-0123	12K 1/4W 5%	R905, 915
471-0472	4.7K 1/4W 5%	R907, 938, 939
471-0474	470K 1/ W 5%	R910
460-0016	1.2K 1/4W 5%	R914

<u>PART NO.</u>	<u>DESCRIPTION</u>	<u>RES. DES.</u>
EHT SUPPLY ASSEMBLY CONT'D		
RESISTORS		
475-0043	200 Ohms Control	R917
475-0044	2K Control	R918
470-0271	270 Ohm 1/4W 5%	R923
470-0471	470 Ohm 1/4W 5%	R924
471-0240	24 Ohm 1/2W 5%	R925
470-0330	33 Ohm 1/4W 5%	R927
470-0680	68 Ohm 1/4W 5%	R930
462-0001	68 Ohm 1W 5%	R932
464-0114	470K Control	R933
470-0333	33K 1/4W 5%	R935
470-0274	270K 1/4W 5%	R936
471-0475	4.7M 1/2W 5%	R937
471-0331	330 Ohm 1/2W 10%	R940
472-0470	47 Ohm 1W 5%	R941
470-0562	5.6K 1/4W 5%	R942
EHT SUPPLY ASSEMBLY KIT		
482-0242	PWR Transistor 5A 1400V	Q900
475-0035	Focus Control	R922
EHT REGULATOR ASSEMBLY		
SEMI-CONDUCTORS		
482-0268	2N 6558	Q320, 321, 323
482-0269	TIP 47 (Motorola)	Q322
481-0204	1N 5263	ZD340
CAPACITORS		
152-0149	68 pf 500V	C330
151-0108	470 pf 500V	C331
472-0223	22K 1W 5%	R300
471-0683	68K 1/2W 5%	R301
472-0273	27K 1W 5%	R302
471-0473	47K 1/2W 5%	R304

<u>PART NO.</u>	<u>DESCRIPTION</u>	<u>RES. DES.</u>
EHT REGULATOR ASSEMBLY CONT'D		
RESISTORS		
470-0331	330 Ohm 1/4W 5%	R305
471-03R3	3.3 Ohm 1/2W 5%	R306
470-0363	36K 1/4W 5%	R307
460-0008	47K 1/4W 5%	R308
475-0048	10K Control Pot.	R310
DEFLECTION AMP PCB ASSEMBLY		
SEMI-CONDUCTORS		
315-0117	Input Amplifier IC	IC600
481-0202	Rectifier	D400-403
481-0020	Rectifier 1A 200V	D404-407, 409, D408, 601-605 701-705
481-0006	Diode 1N 914	
481-0204	Zener Diode 1N 5263B 1/2W 56V	ZD400
481-0205	Zener Diode 1N 5239B 1/2W 9.1V	ZD401
481-0179	Zener Diode 9.1V 1W 5%	ZD402
482-0248	Transistor TIB 29B	Q400, 401
482-0244	Transistor MPSU60 (Motorola)	Q600, 700
482-0245	Transistor 300V 1/2A	Q601, 604, 701, 704
482-0243	Transistor MPSU10 (Motorola)	Q602, 603, 702 704
CAPACTORS		
150-0211	100 uf 80V	C401
150-0212	680 uf 160V	C402
150-0213	6800 uf 80V	C403, 404
150-0004	10 uf 25V	C405
151-0046	Ceramic 0.1 uf	C407, 621, 721
152-0056	0.1 uf 200V	C410
150-0220	22 uf 250V	C411



19" X-Y COL

<u>PART NO.</u>	<u>DESCRIPTION</u>	<u>RES. DES.</u>
DEFLECTION AMP PCB ASSEMBLY CONT'D		
CAPACITORS		
152-0145	2.2 pf 500V	C600
152-0146	12 pf 500V	C603, 703
152-0147	100 pf 10% 500V	C620, 720
152-0023	47 pf 10% 500V	C622, 722
151-0107	0.068 uf 200V	C624, 724
152-0149	5.6 pf 10%	C702
152-0150	560 pf 500V 20%	C725
RESISTORS		
478-0006	Thermistor 120V 60 Ohm	R400
473-0330	33 Ohm 4W 10%	R401
472-0223	22K 1W 10%	R402
470-0222	2.2K 1/4W 5%	R403
474-0220	220 Ohm 10W	R404
471-0822	8.2 1/2W 5%	R405
474-0680	680 Ohm 6W	R406
470-0472	4.7K 1/4W 5%	R410
470-0275	2.7M 1/4W 5%	R411
470-0155	1.5M 1/4W 5%	R412
470-0621	620 Ohm 1/4W 5%	R600
471-0911	910 Ohm 1/4W 5%	R601
470-0103	10K 1/4W 5%	R602
470-0182	1.8K 1/4W 5%	R603, 624, 724
470-0303	30K 1/4W 5%	R604
475-0037	50K Trim Pot	R605
470-0104	100K 1/4W 5%	R606
470-0242	2.4K 1/4W 5%	R607, 710
470-0102	1K 1/4W 5%	R608, 636, 637, 715, 736, 737
475-0038	1K Trim Pot	R611
470-0183	18K 1/4W 5%	R620, 720

<u>PART NO.</u>	<u>DESCRIPTION</u>	<u>RES. DES.</u>
DEFLECTION AMP PCB ASSEMBLY CONT'D		
RESISTORS		
470-0622	6.2K 1/4W 5%	R621, 721
470-0181	180 Ohm 1/4W 5%	R622, 625, 631, 722, 725, 731
470-0223	22K 1/4W 5%	R623, 704, 705, 723
470-0101	100 Ohm 1/4W 5%	R626, 629, 726, 729
471-0183	18K 1/2W 10%	R627, 727
470-0271	270 Ohm 1/4W 5%	R628, 728
471-0223	22K 1/2W 5%	R630, 730
472-0471	470 Ohm 2W 5%	R632
470-0151	150 Ohm 1/4W 5%	R633
460-0056	82 Ohm 1/4W %%	R634
474-0150	1.5 Ohm 10W	R635
470-0222	2.2K 1/4W 5%	R700, 701
475-0039	5K Trim Pot	R702
470-0153	15K 1/4W 5%	R703, 706
470-0152	1.5K 1/4W 5%	R714
472-0391	390 Ohm 2W 5%	R732
470-0475	4.7M Trim Pot	R930, 931
CRT SOCKET PCB ASSEMBLY		
SEMI-CONDUCTORS		
482-0243	Transistor MPS u10 (Motorola)	Q100-105
LAMPS		
390-0107	Lamp	NE100-103
CAPACITORS		
151-0067	100 pf 500V	C100, 110, 130
151-0112	0.1 uf 200V	C101
151-0050	0.01 uf 500V 10%	C102, 111, 131
151-0096	0.01 uf 1000V	C112, 113

<u>PART NO.</u>	<u>DESCRIPTION</u>	<u>RES. DES.</u>
RESISTORS		
470-0101	100 Ohm 1/4W 5%	R101, 112, 130
470-0275	2.7K 1/4W 5%	R102, 113, 131
462-0056	3.3K 1W 5%	R103, 114, 132
472-0471	470 Ohm 1/4W 5%	R104, 115
470-0122	1.2K 1/4W 5%	R105, 116, 134
475-0041	250 Ohm Trim Pot	R106, 117
475-0042	2.5K Trim Pot	R107, 118, 136
471-0222	22K 1/2W 5%	R108, 119, 137
470-0181	180 Ohm 1/4W 5%	R109, 121
470-0102	1K 1/4W 5%	R110
471-0224	220K 1/2W 5%	R122
471-0102	1K 1/2W 5%	R123
471-0474	470K 1/2W 5%	R124
470-0621	620 Ohm 1/4W 5%	R133
HEAT SINK ASSEMBLY		
482-0260	2N 6259	Q605, 606, 705, 706
260-0010	Motor Blower Fan	M01
MISCELLANEOUS		
200-0040	CRT	V01
180-0009	Deflection Yoke	DY01
180-0017	Degaussing Coil	L100
213-0019	CRT PCB Socket	J101
280-0208	Yoke Wedge	X
800-0307	Input Limiter PCB	X
800-0318	Input Clamp PCB	X

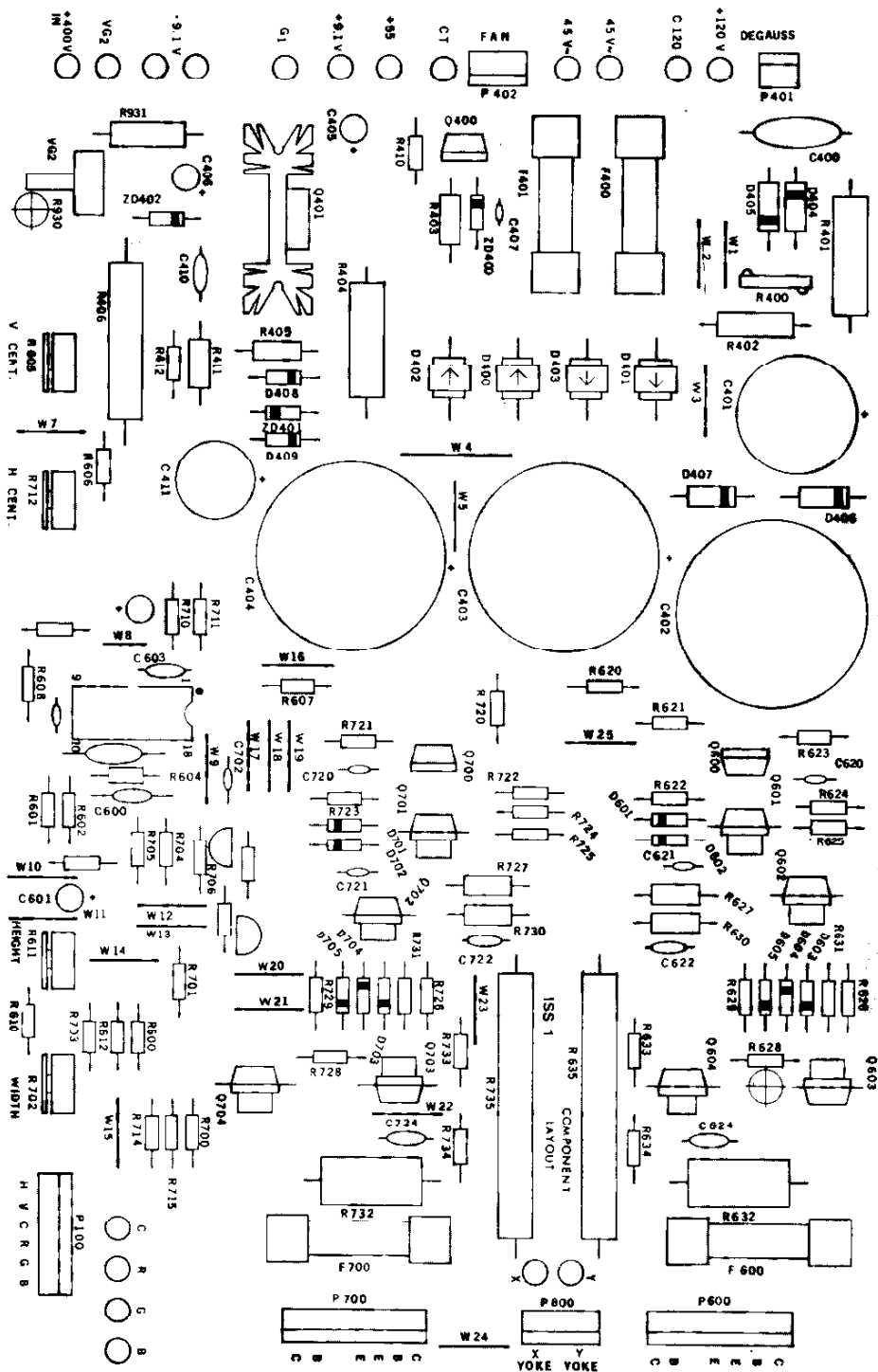

X-Y P.C.B. COMPONENT LAYOUT

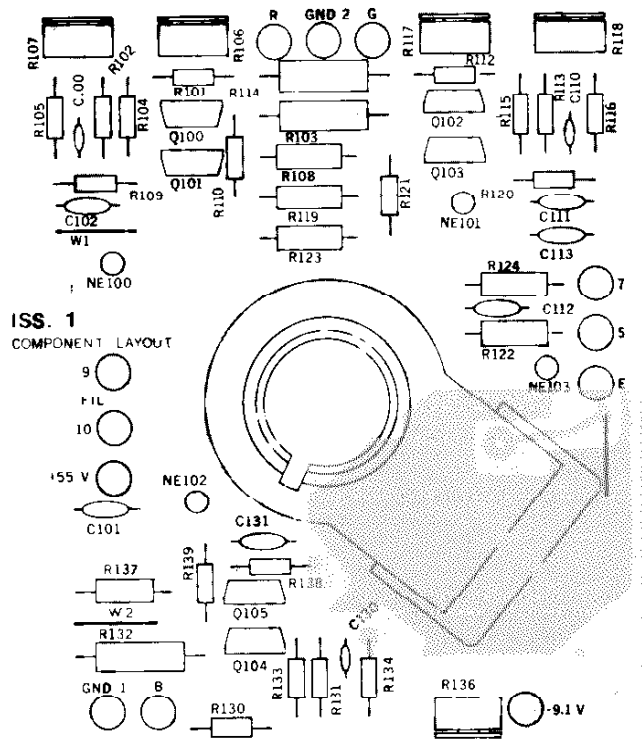

C.R.T. P.C.B. COMPONENT LAYOUT

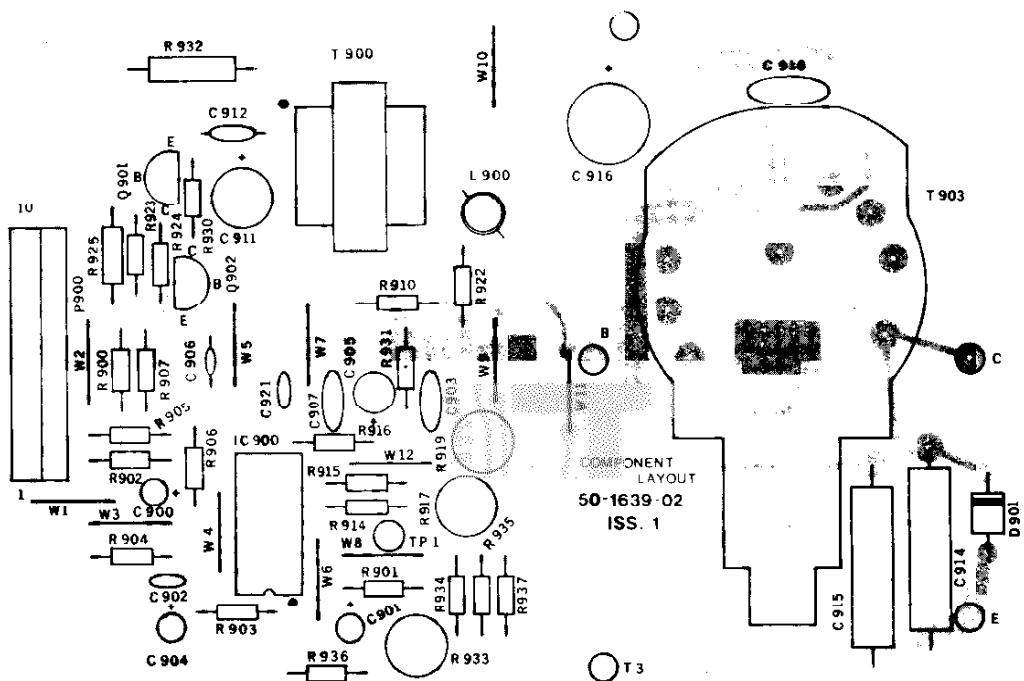

EHT P.C.B. COMPONENT LAYOUT

## G-80 CAGE UNIVERSAL ASSEMBLY

DRAWING NUMBER 800-0296

<u>ITEM NO.</u>	<u>PART NO.</u>	<u>QTY REQD.</u>	<u>DESCRIPTION</u>
1	250-0456	1	G-80 Cage Assembly
2	250-0499	2	G-80 Cage Bracket
3	280-0343	1	Split Grommet
4	420-0560	1	Test Button Decal
5	800-0105	1	6-Slot Master Board Assembly
6	281-0045-06	6	Pan Head Phillips Screw, Type AB, 10-12 x .375 Lg
7	281-0001-12	4	Pan Head Phillips Machine Screw, #4-40x3/4
8	281-0001-06	4	Pan Head Phillips Machine Screw, #4-40x3/8
9	284-0001-00	4	Flat Washer, #4

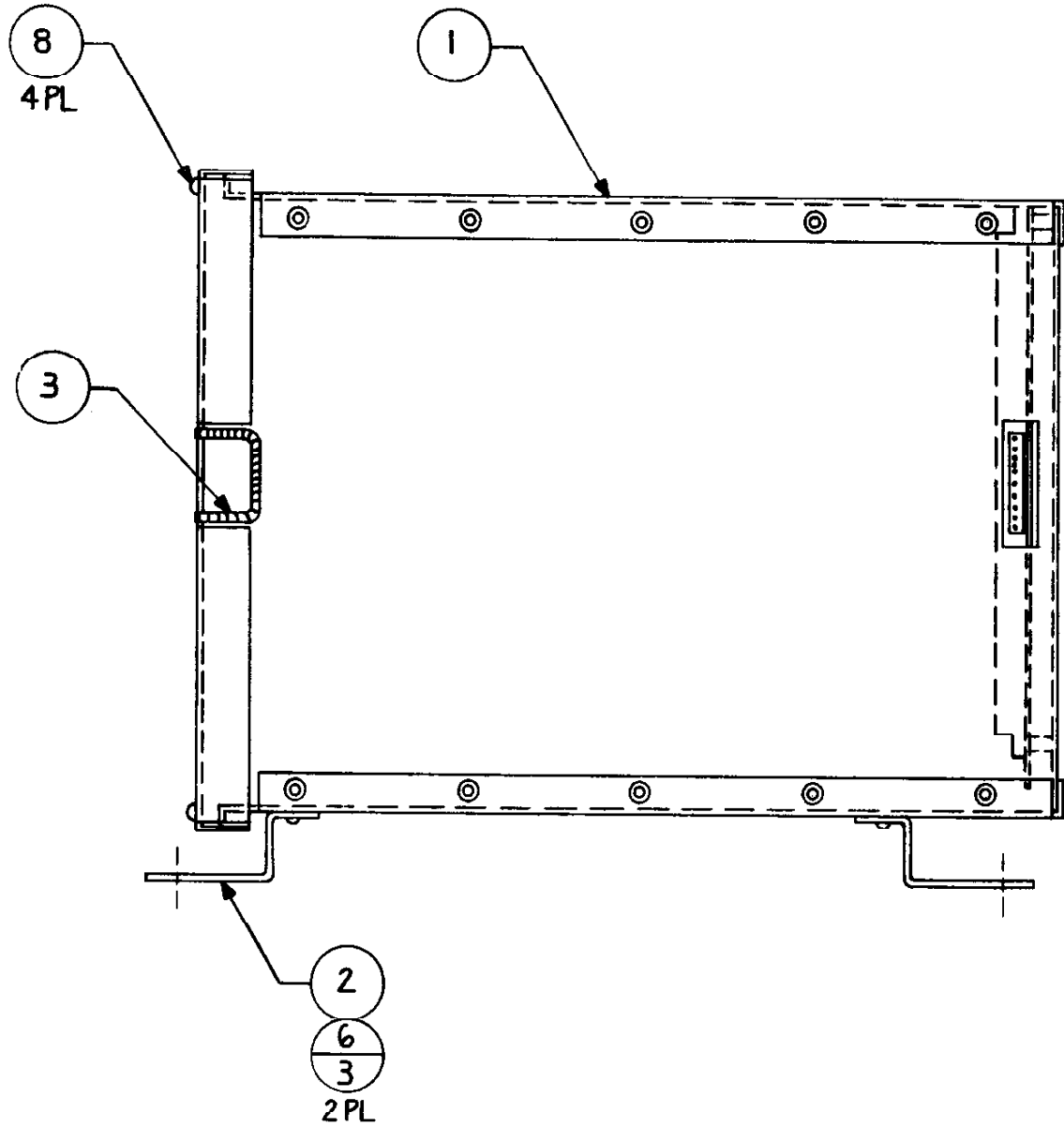

G-80 CAGE UNIVERSAL #2 ASSEMBLY

800-0296

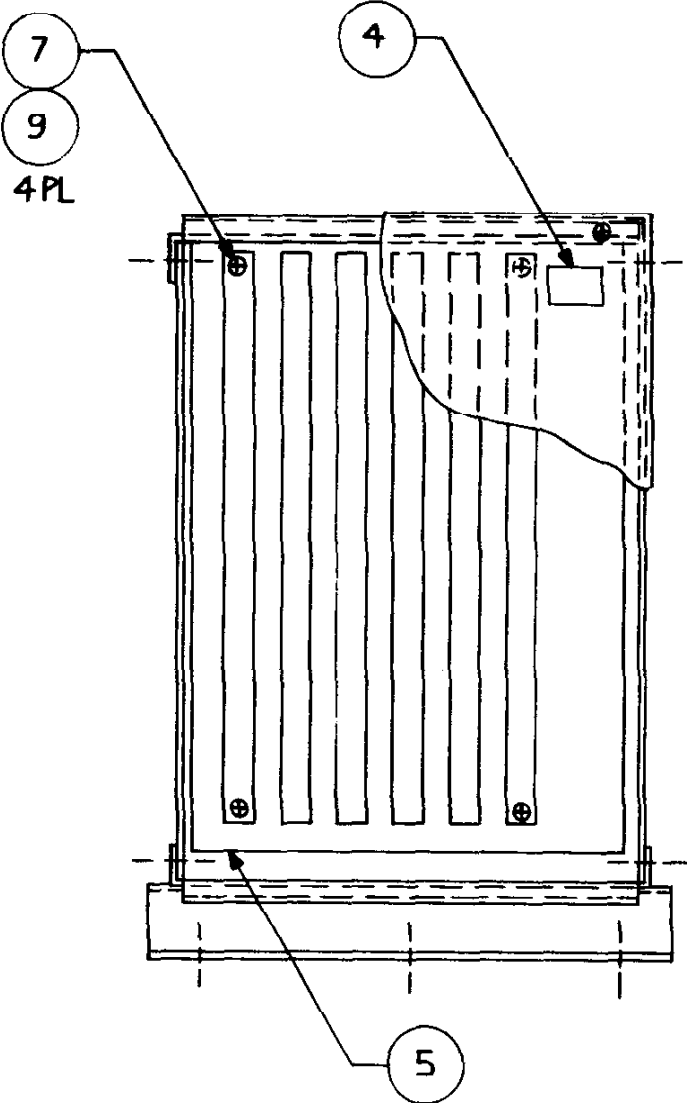



<u>ITEM NO.</u>	<u>PART NO.</u>	<u>QTY</u> <u>REQD.</u>	<u>DESCRIPTION</u>	<u>REF DES.</u>
1	151-0058	13	Ceramic Capacitor, .01 uf, 16V AX	C2, C4, C6, C8, C9 C11, C14, C16, C18 C21, C23, C25, C27
2	151-0060	15	Ceramic Capacitor, .1 uf, 16V AX	C1, C3, C5, C7, C10, C12, C13, C15 C17, C19, C20, C22 C24, C26, C28
3	170-0211	1	PC Board	
4	213-0001	23	24-Pin Dual Inline Socket	XU1-XU23
5	314-0055	1	IC 74LS244	U25
6	314-0058	3	IC 74LS08	U26-U28
7	314-0059	1	IC 74LS10	U29
8	314-0104	1	IC 74LS138	U30
9	314-0120	1	IC 74LS154	U24
10	211-0008	3	Test Point Connector Pin	TP1-TP3
11	150-0088	1	Electrolytic Capacitor, 10 uf, 25V	C29
12	280-0420	2	Card Ejector, Snap On	

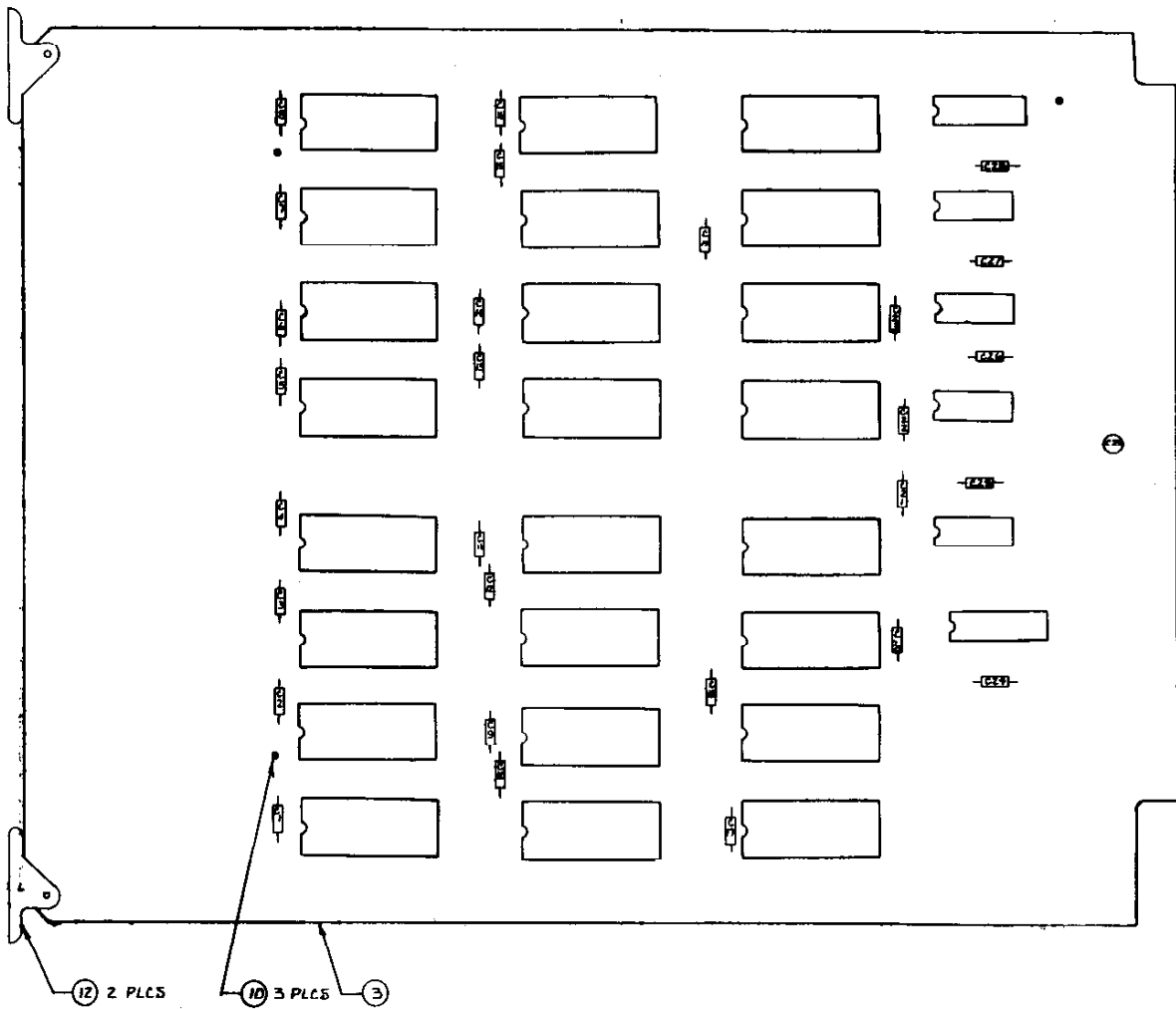

## CPU BOARD ASSEMBLY

DRAWING NUMBER 800-0107

<u>ITEM NO.</u>	<u>PART NO.</u>	<u>QTY</u> <u>REQD.</u>	<u>DESCRIPTION</u>	<u>REF DES.</u>
1	150-0088	3	Cap E 10 uf 25V	C43, C46, C62
2	151-0005	1	Cap CER 680 pf 50V	C50
3	151-0012	1	Cap CER .1 uf 50V	C47
4	151-0020	1	Cap CER 33 pf 50V	C49
5	151-0060	21	Cap CER .1 uf 16V AX	C37-C42, C44, C48, C51-C61, C63, C64
6	151-0061	36	Cap CER 220 pf 16V AX	C1-C36
7	170-0194	1	PC Board	
8	211-0008	4	Conn Pin Test PT	TP1-TP4
9	212-0098	4	Conn M 10 Pin RTA	
10	230-0013	1	XTAL 8.000 MHZ	Y1
11	314-0001	1	IC NE555	U12
12	314-0015	1	IC 7404	U30
13	314-0018	4	IC 74LS00	U6, U8, U14, U19
14	314-0019	1	IC 74LS04	U18
15	314-0055	3	IC 74LS244	U34, U36, U38
16	314-0058	1	IC 74LS08	U13
17	314-0062	5	IC 74LS74	U10, U11, U17, U20, U39
18	314-0066	1	IC 74LS27	U16
19	314-0067	1	IC 74LS30	U37
20	314-0068	2	IC 74LS32	U32, U33
21	314-0078	1	IC 74LS^2	U23
22	314-0083	1	IC 74LS240	U4
23	314-0085	2	IC 74LS14	U7, U31
24	314-0087	1	IC 74LS139	U24
25	314-0093	1	IC 74LS374	U3
26	314-0099	1	IC 74LS245	U35
27	314-0105	4	IC 74LS253	U1, U2, U5, U9
28	315-0041	1	IC Z80A	U22
29	315-0046	4	IC 2114	U26-U29

<u>ITEM NO.</u>	<u>PART NO.</u>	<u>QTY</u> <u>REQD.</u>	<u>DESCRIPTION</u>	<u>REF DES.</u>
30	315-0050	1	IC 2516 (2716)	U25
31	316-0764	1	IC Prom 32x8	U15
32				
33	390-0003	1	Led Red	D3
34	471-0101	1	Res 100 Ohm 1/2W 5%	R5
35	471-0102	2	Res 1K Ohm 1/2W 5%	R1, R3
36	471-0103	1	Res 10K Ohm 1/2W 5%	R6
37	471-0104	3	Res 100K Ohm 1/2W 5%	R7, R8, R22
38	471-0122	1	Res 1.2K Ohm 1/2W 5%	R12
39	471-0220	1	Res 22 Ohm 1/2W 5%	R14
40	471-0221	3	Res 220 Ohm 1/2W 5%	R2, R4, R13
41	471-0331	8	Res 330 Ohm 1/2W 5%	R10, R11, R15-R20
42	477-0002	3	Res Pack 15x2.2K	RP1-RP3
43	481-0001	2	Diode 1N4002	D1, D2
44	481-0006	1	Diode 1N914/IN4148	D4
45	482-0006	1	XSTR N4403	Q7
46	482-0010	2	XSTR PE8050	Q1, Q2
47	482-0014	5	XSTR N4401	Q3-Q6, Q8
48	510-0052	1	SWITCH PIANO DIP	SW1
49	510-0053	1	SW Pushbutton Side PCM	SW3
50	213-0001	1	SKT 24 Pin Dual INLN	XU25
51	213-0002	4	SKT 18 Pin Dual INLN	XU26-XU29
52	213-0004	1	SKT 16 Pin Dual INLN	XU15
53	213-0005	2	SKT 40 Pin Dual INLN	XU21, XU22
54	510-0049	1	Switch 8 Pos Dip	SW2
55	471-0472	1	Res 4.7K Ohm 1/2W 5%	R21
56	280-0420	2	Card Ejector, Snap On	
57	471-0473	1	Res 47K Ohm 1/2W 5%	R9
58	151-0031	1	Cap CER .22 uf 16V	C45

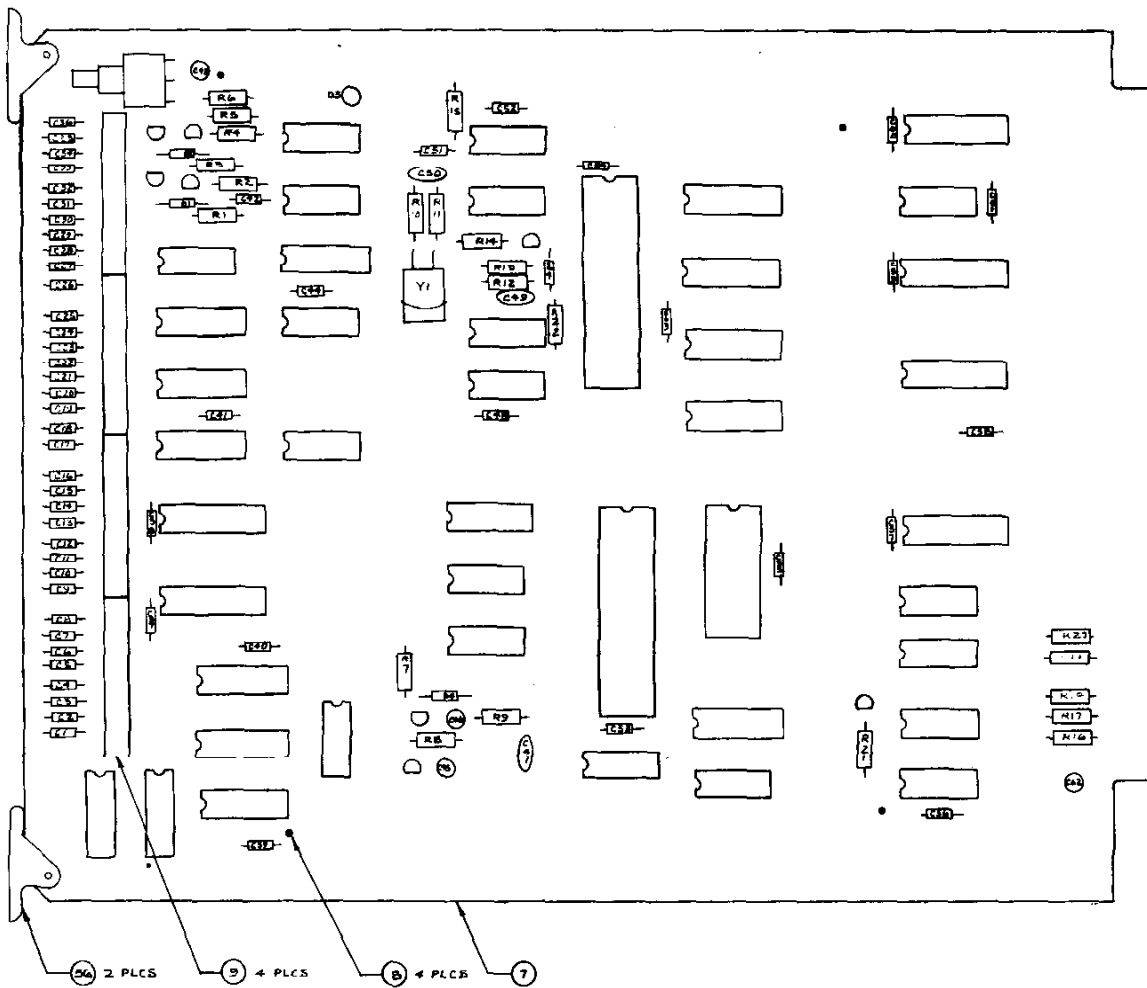

## X-Y TIMING ASSEMBLY

DRAWING NUMBER 800-0161

<u>ITEM NO.</u>	<u>PART NO.</u>	<u>QTY</u> <u>REQD.</u>	<u>DESCRIPTION</u>	<u>REF DES.</u>
1	151-0005	1	Cap CER 680 pf 50V	C7
2	151-0058	25	Cap .01 uf 16V AX	C1-C3, C6, C8-C28
3	170-0218	1	PC Board	
4	211-0008	1	Conn Pin Test PT	TP1
5	212-0101	1	Conn 4 Pin M RTA	
6	213-0001	3	SKT 24 Pin Dual INLN	XP1, XU39, XU50
7	213-0004	2	SKT 16 Pin Dual INLN	XU1, XU4
8	213-0010	2	SKT 8 Pin Dual INLN	XU2, XU3
9	230-0009	1	Xtal 15.46848	Y1
10	280-0420	2	Card Ejector	
11	313-0004	2	IC LM741EN Dip	U2, U3
12	313-0044	2	IC AD561	U1, U4
13	314-0018	1	IC 74LS00	U28
14	314-0019	2	IC 74LS04	U30, U40
15	314-0040	1	IC 74LS125	U27
16	314-0046	1	IC 74LS04	U14
17	314-0055	3	IC 74LS244	U54, U57, U58
18	314-0058	2	IC 74LS08	U13, U21
19	314-0062	5	IC 74LS74	U25, U26, U42, U43, U52
20	314-0070	1	IC 74LS86	U29
21	314-0073	4	IC 74LS175	U35-U38
22	314-0074	6	IC 74LS191	U15-U20
23	314-0076	6	IC 74LS157	U5-U10
24	314-0078	1	IC 74LS02	U53
25	314-0093	4	IC 74LS374	U48, U49, U55, U56
26	314-0097	6	IC 74LS161	U31-U34, U41, U51
27	314-0101	4	IC 74LS283	U44-U47
28	314-0108	4	IC 74LS107	U11, U22-U24
29	314-0120	1	IC 74LS154	U50
30	314-0135	1	IC 74LS11	U12

<u>ITEM NO.</u>	<u>PART NO.</u>	<u>QTY</u> <u>REQD.</u>	<u>DESCRIPTION</u>	<u>REF DES.</u>
31	315-0019	1	IC 2708	U39
32	471-0202	2	Res 2K Ohm 1/2W 5%	R2, R4
33	471-0331	2	Res 330 Ohm 1/2W 5%	R7, R8
34	471-0392	2	Res 3.9K Ohm 1/2W 5%	R1, R5
35	475-0024	2	Pot 1K 10 Turn	R3, R6
36	151-0008	2	Cap CER .001 uf 50V	C29, C30
37	150-0088	2	Cap E 10 uf 25V RDL	C4, C5
38	151-0042	1	Cap, Cer 470 pf 50V	C31
39	481-0006	2	1N914 Diode	D1, D2
40	151-0002	2	Cap CER 100 pf 50V	C32, C33

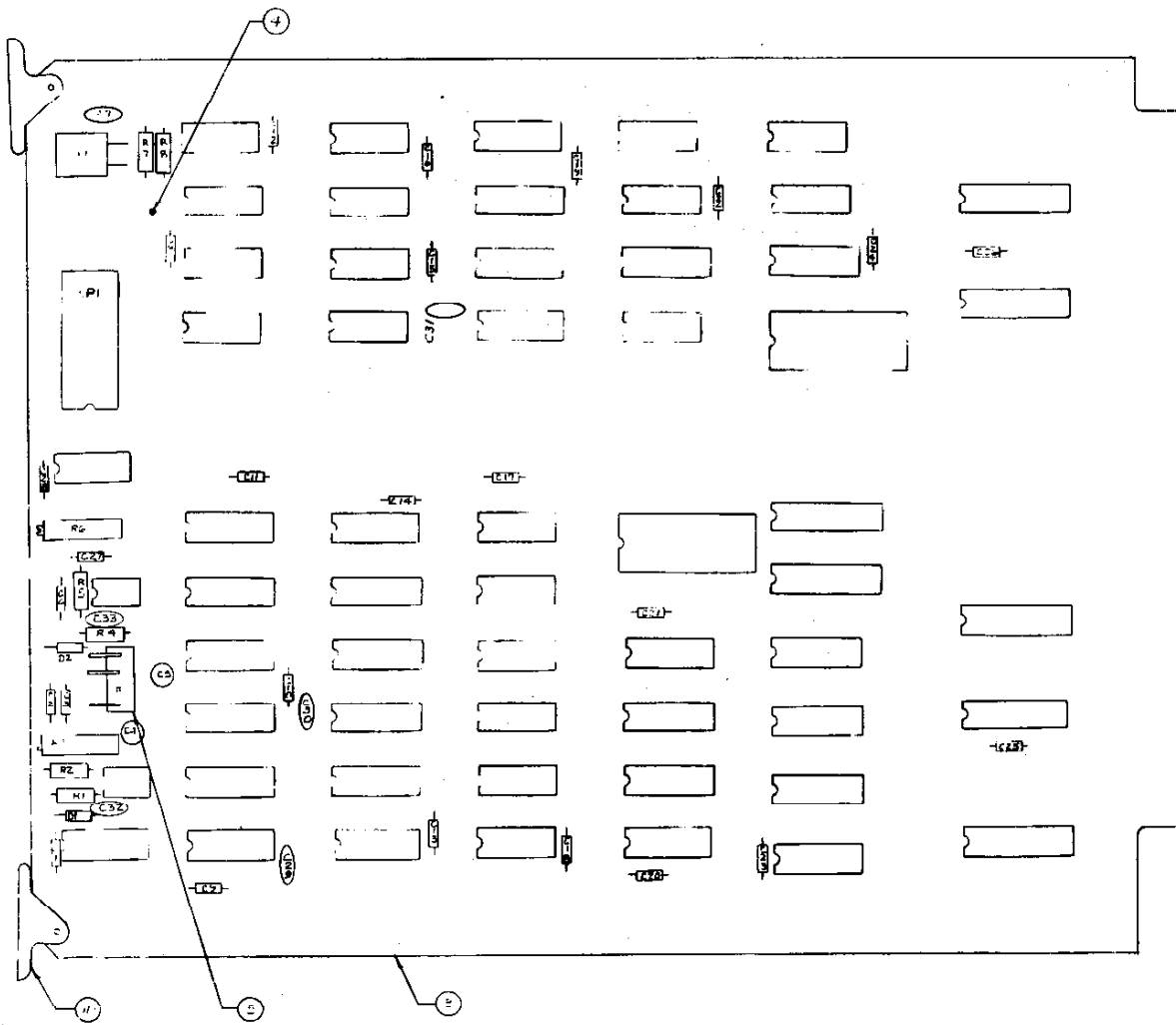



## X-Y CONTROL ASSEMBLY

DRAWING NUMBER 800-0163

ITEM NO.	PART NO.	QTY		DESCRIPTION	REF DES.
		REQD.			
1	150-0088	1		Cap E 10 uf 25V	C23
2	151-0002	1		Cap CER 100 pf 50V	C14
3	151-0058	21		Cap CER .01 uf 16Y AX	C1-C13, C15-C22
4	170-0219	1		PC Board	
5	212-0101	1		Conn 4 Pin M RTA	
6	213-0001	1		SKT 24 Pin Dual INLN	XPI
7	280-0330	2		Card Ejector	
8	314-0018	1		IC 74LS00	U40
9	314-0019	3		IC 74LS04	U9, U32, U42
10	314-0040	1		IC 74LS125	U39
11	314-0055	7		IC 74LS244	U20, U21, U35, U36, U48, U49, U54
12	314-0058	1		IC 74LS08	U37
13	314-0059	2		IC 74LS10	U18, U41
14	314-0060	1		IC 74LS20	U50
15	314-0062	2		IC 74LS74	U19, U51
16	314-0067	1		IC 74LS30	U47
17	314-0068	2		IC 74LS32	U4, U38
18	314-0074	3		IC 74LS191	U15-U17
19	314-0075	1		IC 74LS393	U22
20	314-0078	1		IC 74LS02	U23
21	314-0087	1		IC 74LS139	U46
22	314-0093	2		IC 74LS374	U2, U13
23	314-0097	5		IC 74LS161	U10-U12, U34, U52
24	314-0099	1		IC 74LS245	U14
25	314-0101	1		IC 74LS283	U33
26	314-0108	1		IC 74LS107	U53
27	314-0127	1		IC 74LS164	U3
28	314-0128	4		IC 74LS95	U6, U7, U44, U45
29	314-0137	2		IC 74LS09	U1, U5
30	315-0046	8		IC 2114	U24-U31

<u>ITEM NO.</u>	<u>PART NO.</u>	<u>QTY</u> <u>REQD.</u>	<u>DESCRIPTION</u>	<u>REF DES.</u>
31	315-0072	2	IC AM25LS14	U8, U43
32	471-0123	3	Res 12K Ohm 1/2W 5%	R1, R3, R5
33	471-0472	1	Res 4.7K Ohm 1/2W 5%	R7
34	471-0622	3	Res 6.2K Ohm 1/2W 5%	R2, R4, R6
35	481-0006	6	Diode 1N914/1N4148	D1-D6
36	213-0002	8	Socket 18 Pin	XU24-XU31
37	471-0471	1	Res 470 Ohm 1/2W 5%	R8
38	471-0103	1	Res 10K Ohm 1/2W 5%	R9
39	471-0332	1	Res 3.3K Ohm 1/2W 5%	R11
40	471-0512	1	Res 5.1K Ohm 1/2W 5%	R10
41	482-0006	1	XSTR 2N4403	Q1
42	482-0014	1	XSTR 2N4401	Q2

# X-Y CONTROL ASSEMBLY

800-0163

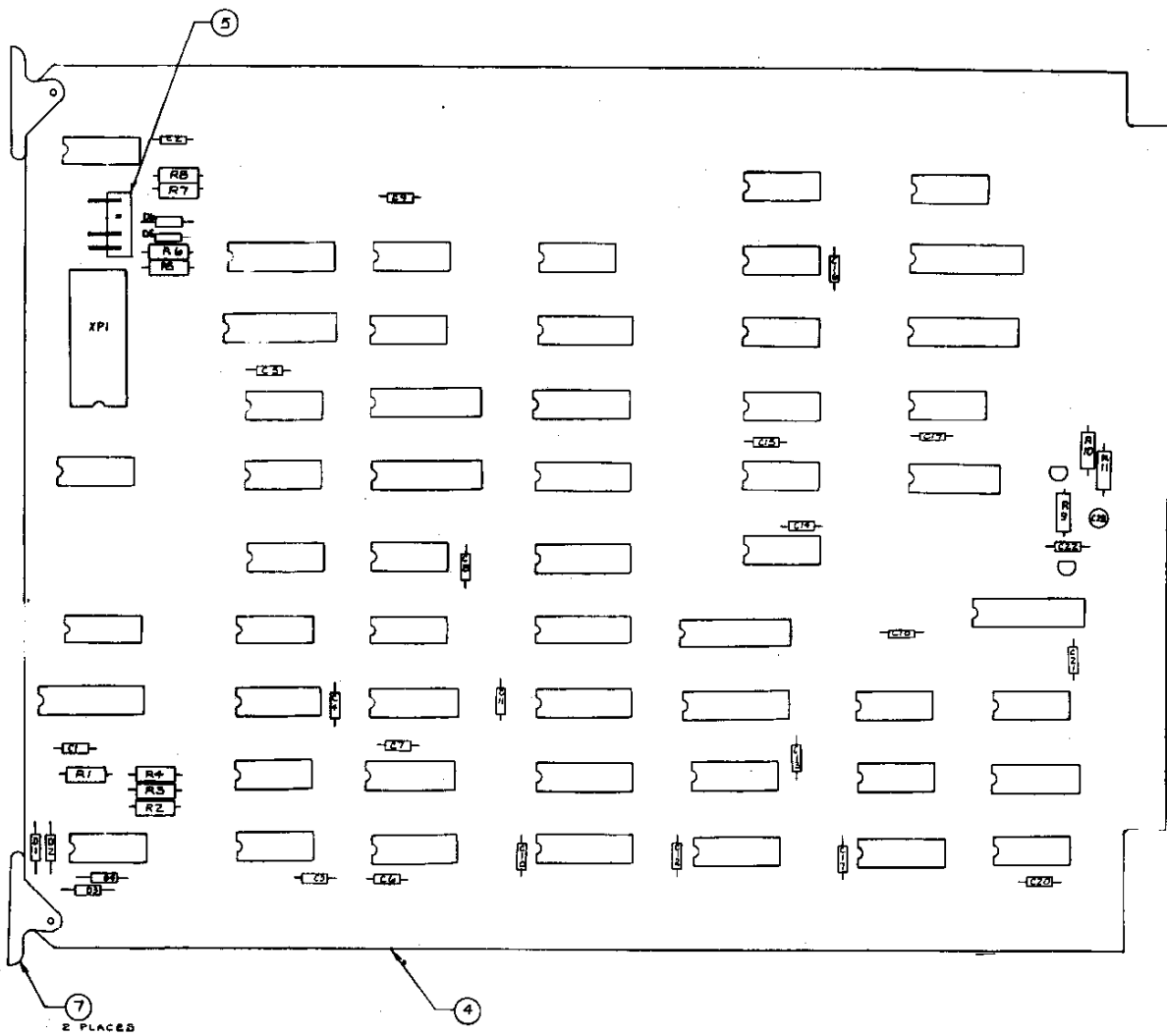

## UNIVERSAL SOUND BOARD ASSEMBLY

DRAWING NUMBER 800-0377

<u>ITEM NO.</u>	<u>PART NO.</u>	<u>QTY</u> <u>REQD.</u>	<u>DESCRIPTION</u>	<u>REF DES.</u>
1	150-0087	2	Cap-E 4.7 f 25V RDL	C1, C4
2	150-0090	1	Cap-E 33 f 25V RDL	C60
3	150-0135	7	Cap-E 1 f 25V RDL	C14, C15, C33- C36, C54
4	151-0002	9	Cap-CER 100 pf 50V	C6-C8, C19-C24
5	151-0021	2	Cap-CER 20 pf 50V	C41, C42
6	151-0060	29	Cap .1 f 16V AX	C3, C5, C10-C12, C18, C26-C31, C37-C40, C43- C-50, C57-C59, C61, C62
7	152-0011	3	Cap-F .15 f 50V	C51, C55, C56
8	152-0085	6	Cap-F .01 f 50V	C9, C13, C16, C17, C25, C32
9	152-0144	1	Cap-F .082 f 50V	C53
10	170-0259	1	PC Board	
11	212-0081	1	Conn 4 Pin M RTG PLZD	P1
12	213-0001	2	Skt 24 Pin Dual INLN	XU50, XU51
13	213-0002	2	Skt 18 Pin Dual INLN	XU44, XU45
14				
15	213-0005	1	Skt 40 Pin Dual INLN	XU46
16	230-0037	1	XTAL 6.0 MHz	Y1
17	280-0420	2	Card Ejector Snap On	
18	313-0037	1	IC TL081	U49
19	313-0038	13	IC TL082	U1, U3-U6, U9, U17-U23
20	314-0018	1	IC 74LS00	U36
21	314-0055	1	IC 74LS244	U55
22	314-0060	1	IC 74LS20	U40
23	314-0062	2	IC 74LS74	U2, U38
24	314-0067	1	IC 74LS30	U59

<u>ITEM NO.</u>	<u>PART NO.</u>	<u>QTY</u> <u>REQD.</u>	<u>DESCRIPTION</u>	<u>REF DES.</u>
25	314-0068	3	IC 74LS32	U35, U37, U39
26	314-0075	2	IC 74LS393	U32, U33
27	314-0076	3	IC 74LS157	U56-U58
28	314-0085	1	IC 74LS14	U48
29	314-0087	2	IC 74LS139	U10, U11
30	314-0099	2	IC 74LS245	U52, U53
31	314-0100	1	IC 74LS273	U54
32	314-0104	1	IC 74LS138	U34
33	314-0131	1	IC 74LS373	U47
34	315-0035	1	IC MM5837	U60
35	315-0046	2	IC 2114	U44, U45
36	315-0059	3	IC 8253	U41-U43
37	315-0077	1	IC 8035	U46
38	315-0079	6	IC CD4053	U7, U8, U15, U16, U30, U31
39	315-0132	9	IC AD7524	U12-U14, U24-U29
40	315-0133	2	IC 2K x 8 Static RAM	U50, U51
41	470-0102	8	Res 1K Ohm 1/4W 5%	R23, R24, R30, R33, R53, R56, R59, R63
42	470-0103	11	Res 10K Ohm 1/4W 5%	R20-R22, R27, R40, R41, R50- R52, R57, R58
43	470-0104	29	Res 100K Ohm 1/4W 5%	R1, R7-R10, R12, R13, R15, R16, R18, R19, R25, R28, R29, R31, R32, R34-R36, R38, R39, R42, R43, R45, R46, R48, R49, R54, R55

<u>ITEM NO.</u>	<u>PART NO.</u>	<u>QTY</u> <u>REQD.</u>	<u>DESCRIPTION</u>	<u>REF DES.</u>
44	470-0105	2	Res 1M ohm 1/4W 5%	R2, R11
45	470-0124	1	Res 120K Ohm 1/4W 5%	R6
46	470-0222	2	Res 2.2K Ohm 1/4W 5%	R5, R60
47	470-0271	1	Res 270 Ohm 1/4W 5%	R62
48	470-0272	2	Res 2.7K Ohm 1/4W 5%	R64, R65
49	470-0333	4	Res 33K Ohm 1/4W 5%	R14, R37, R44, R61
50	470-0334	1	Res 330K Ohm 1/4W 5%	R3
51	470-0562	3	Res 5.6K Ohm 1/4W 5%	R17, R26, R47
52	470-0332	1	Res 3.3K Ohm 1/4W 5%	R4
53	482-0023	1	XSTR 2N4093	Q1
54	152-0054	1	Cap-F .001 f 50V	C2
55	152-0076	1	Cap-F .1 f 50V	C52
56	212-0158	1	Conn Header 8 Pos	P2
57	212-0159	1	Conn Jumper	

# UNIVERSAL SOUND BOARD ASSEMBLY

800-0377

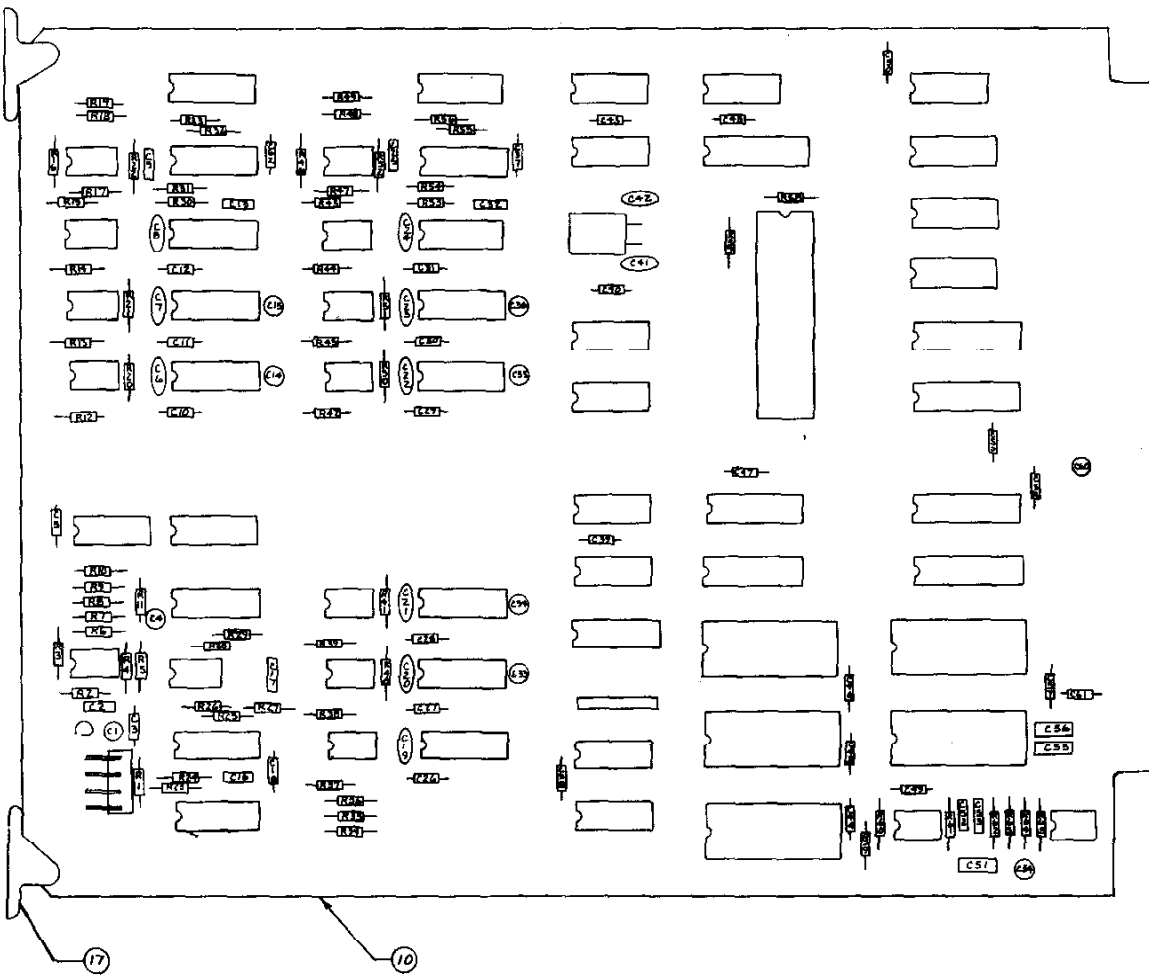

## G-80 POWER SUPPLY CHASSIS ASSEMBLY

DRAWING NUMBER 800-0191

<u>ITEM NO.</u>	<u>PART NO.</u>	<u>QTY</u> <u>REQD.</u>	<u>DESCRIPTION</u>	<u>REF DES.</u>
1	530-0016	1	Heat Sink, G-80 Pwr Sup.	
2	250-0460	1	Chassis Support	
3	250-0461	1	Cover	
4	800-0170	1	PCB Assembly	
5	253-0206	6	PCB Support, Threaded	
6	281-0032-06	8	Thread Forming Screw, #6 Type B, 3/8 long	
7				
8	482-0104	1	Power Transistor	TIP 141
9	313-0023	1	Negative 5 Volt Regulator	320T5
10	313-0014	1	Positive 12 Volt Regulator	340T12
11	313-0015	1	Negative 12 Volt Regulator	320T12
12	482-0100	1	Power Transistor (Audio Amp)	TIP 125
13	482-0019	1	Power Transistor (Audio Amp)	TIP 120
14				
15				
16	420-0557	1	Fuse Decal	
17	280-0117	1	Tab Rivet Male 1/4"	
18	420-0575	1	Power Supply B Decal	
19	281-0001-08	6	Pan Head Phillips Screw, 4-40x1/2" Lg	
20	280-0341-00	6	Shoulder Washer, #4	
21	310-0006-01	6	Transistor Insulator, T0-220	
22	284-0001-00	6	Flat Washer #4	
23	284-0031-00	6	Split Lock Washer #4	
24	283-0021-00	6	Machine Hex Nut, 4-40	
25	800-0243	1	G-80 Transistor Harness Assembly P1	



<u>ITEM NO.</u>	<u>PART NO.</u>	<u>QTY</u> <u>REQD.</u>	<u>DESCRIPTION</u>	<u>REF DES.</u>
26	800-0244	1	G-80 Transistor Harness Assembly, P2	
27	800-0245	1	G-80 Transistor Harness Assembly, P3	
28	800-0246	1	G-80 Transistor Harness Assembly, P4	
29	800-0247	1	G-80 Transistor Harness Assembly, P5	
30	800-0248	1	G-80 Transistor Harness Assembly, P6	
31	310-0007-01	1	Transistor Insulator "H", T0-218	

# G-80 POWER SUPPLY ASSEMBLY

800-0191

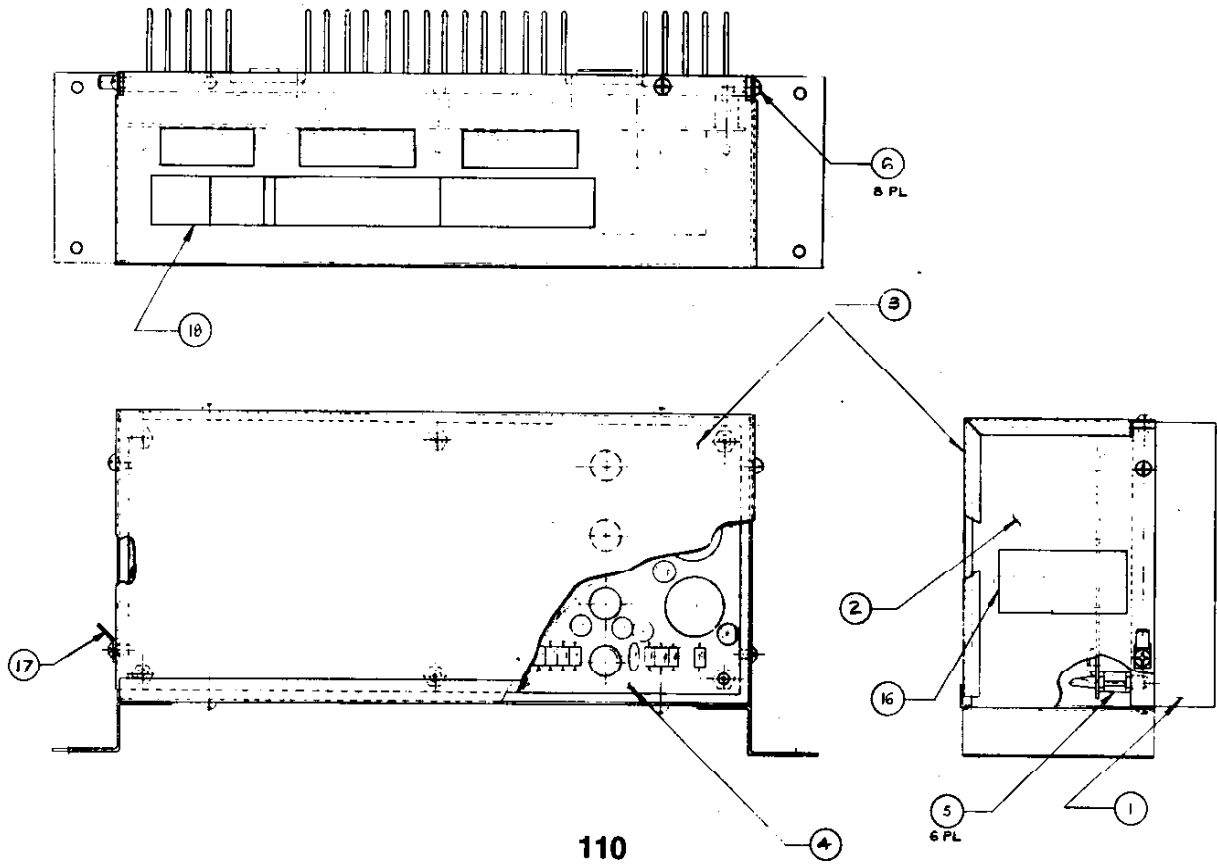
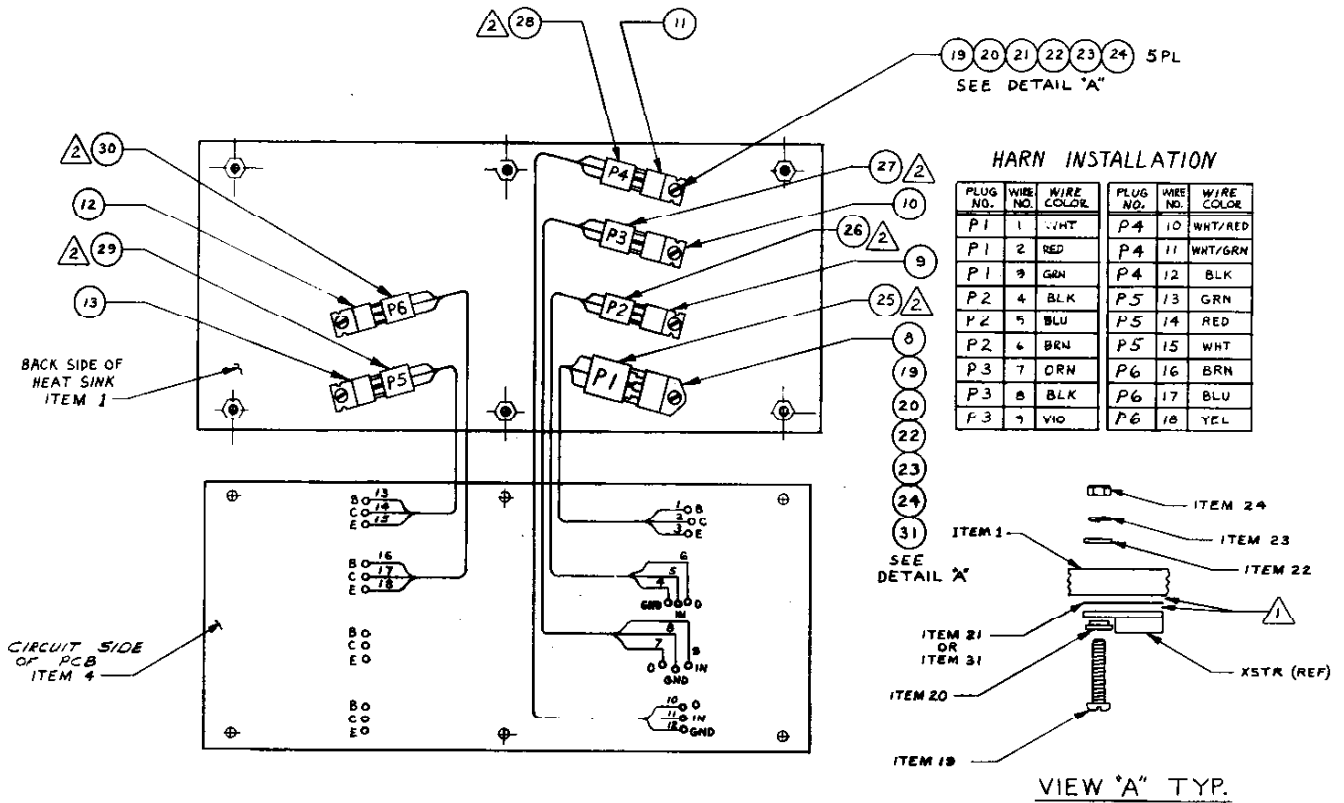

<u>ITEM NO.</u>	<u>PART NO.</u>	<u>QTY</u> <u>REQD.</u>	<u>DESCRIPTION</u>	<u>REF DES.</u>
1	150-0088	9	Electrolytic Capacitor, 10 uf, 25V	C5, C8, C10, C18, C19, C23, C24, C26, C31
2	150-0092	1	Electrolytic Capacitor, 100 uf, 25V	C17
3	150-0095	1	Electrolytic Capacitor, 3300 uf, 25V	C30
4	150-0096	3	Electrolytic Capacitor, 6800 uf, 16V	C32-C34
5	150-0097	4	Electrolytic Capacitor, 4700 uf, 25V	C15, C16, C27, C28
6	151-0002	1	Ceramic Capacitor, 100 pf, 50V	C9
7	151-0007	1	Ceramic Capacitor, .005 uf, 100V	C20
8	151-0011	4	Ceramic Capacitor, .01 uf, 50V	C21, C22, C25, C29
9	151-0012	3	Ceramic Capacitor, .1 uf, 50V	C2, C13, C14
10	151-0021	1	Ceramic Capacitor, 20 pf, 50V	C7
11	170-0222	1	PC Board	
12	212-0020	2	10-Pin Male Connector RTA	
13	212-0081	2	4-Pin Male Connector RTA	
14	313-0001	1	IC LM723 Dip	U1
15	471-0011	1	Resistor, 10 Ohm, 1/2W 5%	R2
16	471-0101	1	Resistor, 100 Ohm, 1/2W 5%	R32
17	471-0102	3	Resistor, 1K Ohm, 1/2W 5%	R10, R27, R29
18	471-0103	2	Resistor, 10K Ohm, 1/2W 5%	R6, R30
19	471-0104	1	Resistor, 100K Ohm, 1/2W 5%	R23
20	471-0222	2	Resistor, 2.2K Ohm, 1/2W 5%	R21, R22

<u>ITEM NO.</u>	<u>PART NO.</u>	<u>QTY</u> <u>REQD.</u>	<u>DESCRIPTION</u>	<u>REF DES.</u>
21	471-0223	2	Resistor, 22K Ohm, 1/2W 5%	R5, R9
22	471-0332	1	Resistor, 3.3K Ohm, 1/2W 5%	R28
23	471-0182	1	Resistor, 1.8K Ohm, 1/2W 5%	R26
24	471-0681	1	Resistor, 680 Ohm, 1/2W 5%	R7
25	473-05R0	1	Resistor, .05 Ohm, 5W 3%	R25
26	473-00R2	2	Resistor, .2 Ohm, 3W 5%	R14, R15
27	475-0004	1	Pot 1K Car PCMTV	R31
28	481-0002	2	Diode MR751	D10, D12
29	481-0004	10	Diode MR501	D6-D9, D11, D13-D17
30	481-0006	3	Diode 1N914/1N4148	D1, D4, D5
31	482-0006	2	Transistor 2N4403	Q1, Q7
32	482-0014	2	Transistor 2N4401	Q2, Q3
33	514-0002	2	Fuse 3A Norm	F1, F2
34	514-0003	8	Clip Fuse Mounting	
35	514-0006	1	Fuse 1.5A Norm	F4
36	514-0008	1	Fuse 10A Slow Blow	F3
37	800-0191	1	Schematic Reference	
38	471-0220	1	Resistor, 22 Ohm, 1/2W 5%	R8
39	471-0221	1	Resistor, 220 Ohm, 1/2W 5%	R33

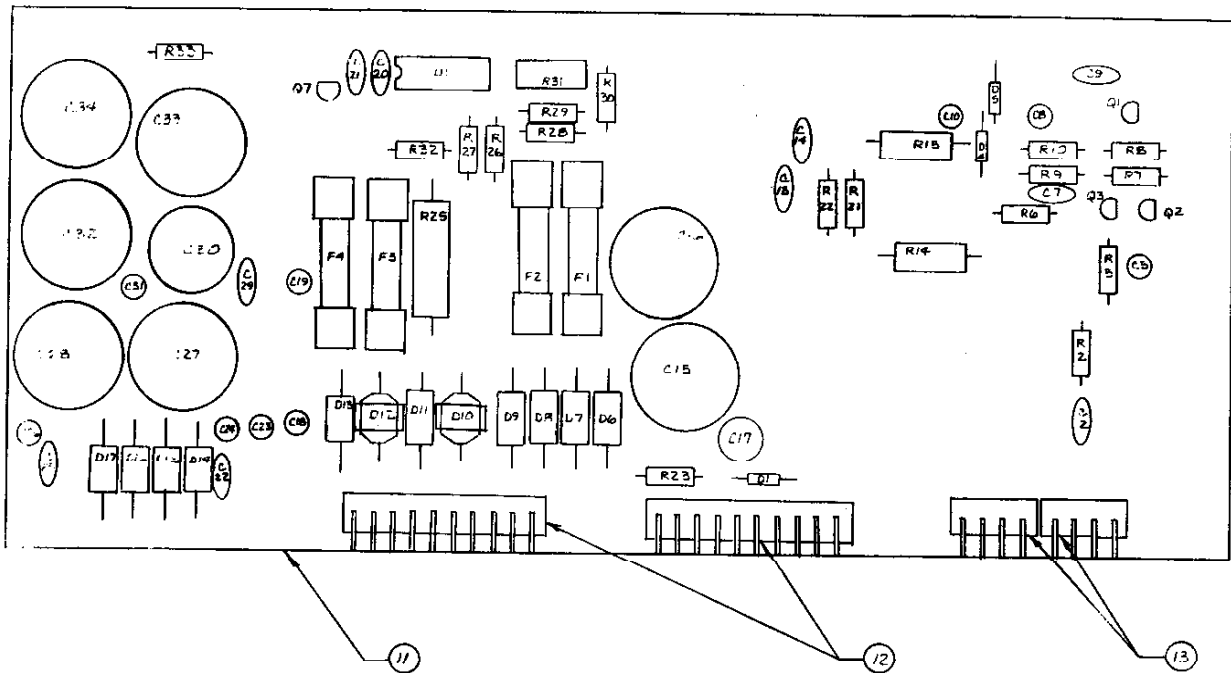

8

7

6

5

\* 800-0290 REF

\* 800-0285 REF

\* 800-0286 REF

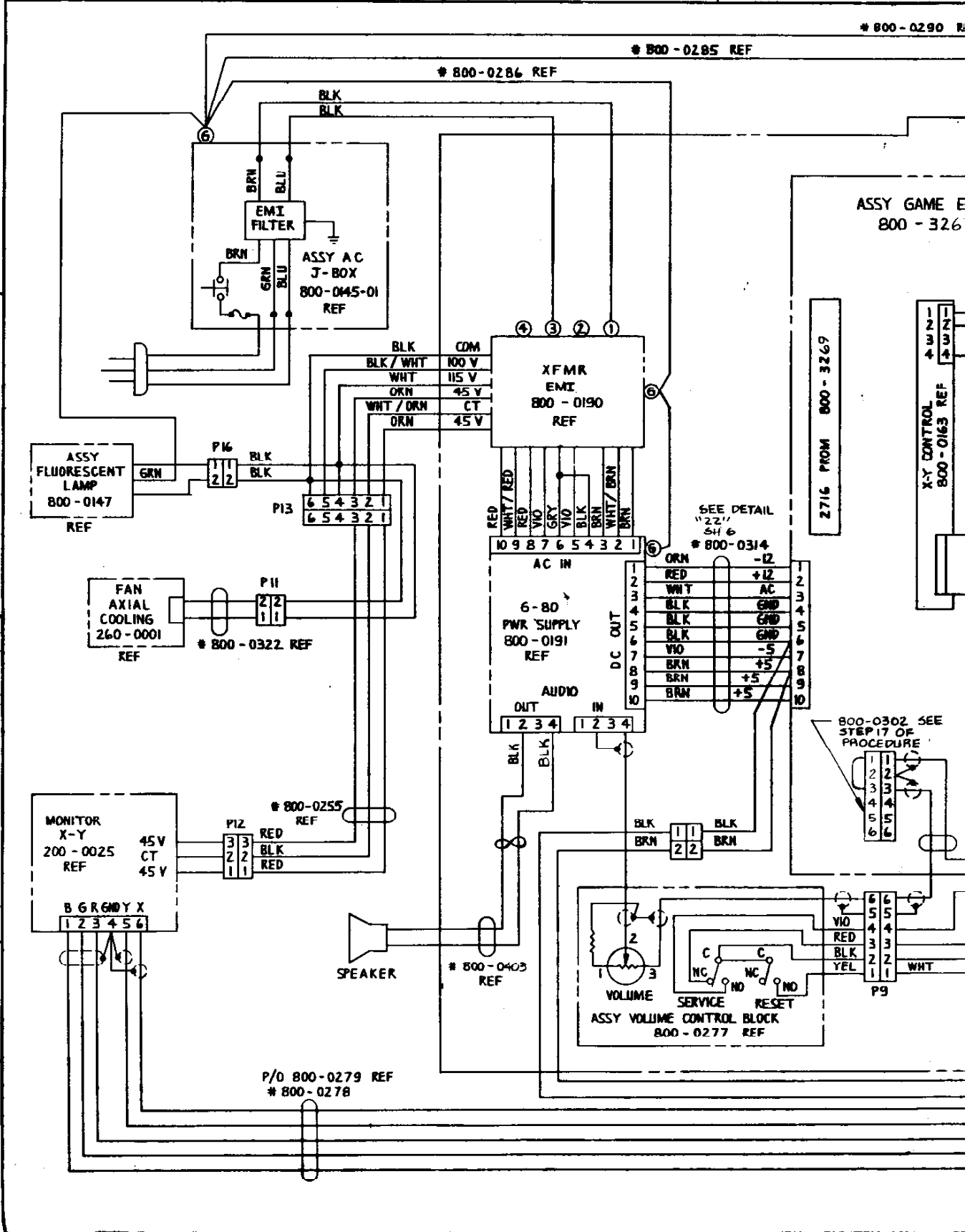

ASSY GAME E  
800-326

2716 FROM 800-3269

1 2 3 4  
1 2 3 4  
X-Y CONTROL  
800-0163 REF

SEE DETAIL  
"22"  
546

\* 800-0314

10	RED	ORN	-12	2
9	WHT/RED	RED	+12	3
8	RED	WHT	AC	3
7	VIO	BLK	GND	4
6	GRY	BLK	GND	5
5	VIO	BLK	GND	6
4	BLK	BRN	-5	7
3	BLK	BRN	+5	8
2	BRN	BRN	+5	9
1	BRN	BRN	+5	10

800-0302 SEE  
STEP 17 OF  
PROCEDURE

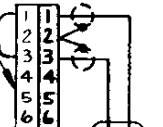

P/O 800-0279 REF  
\* 800-0278

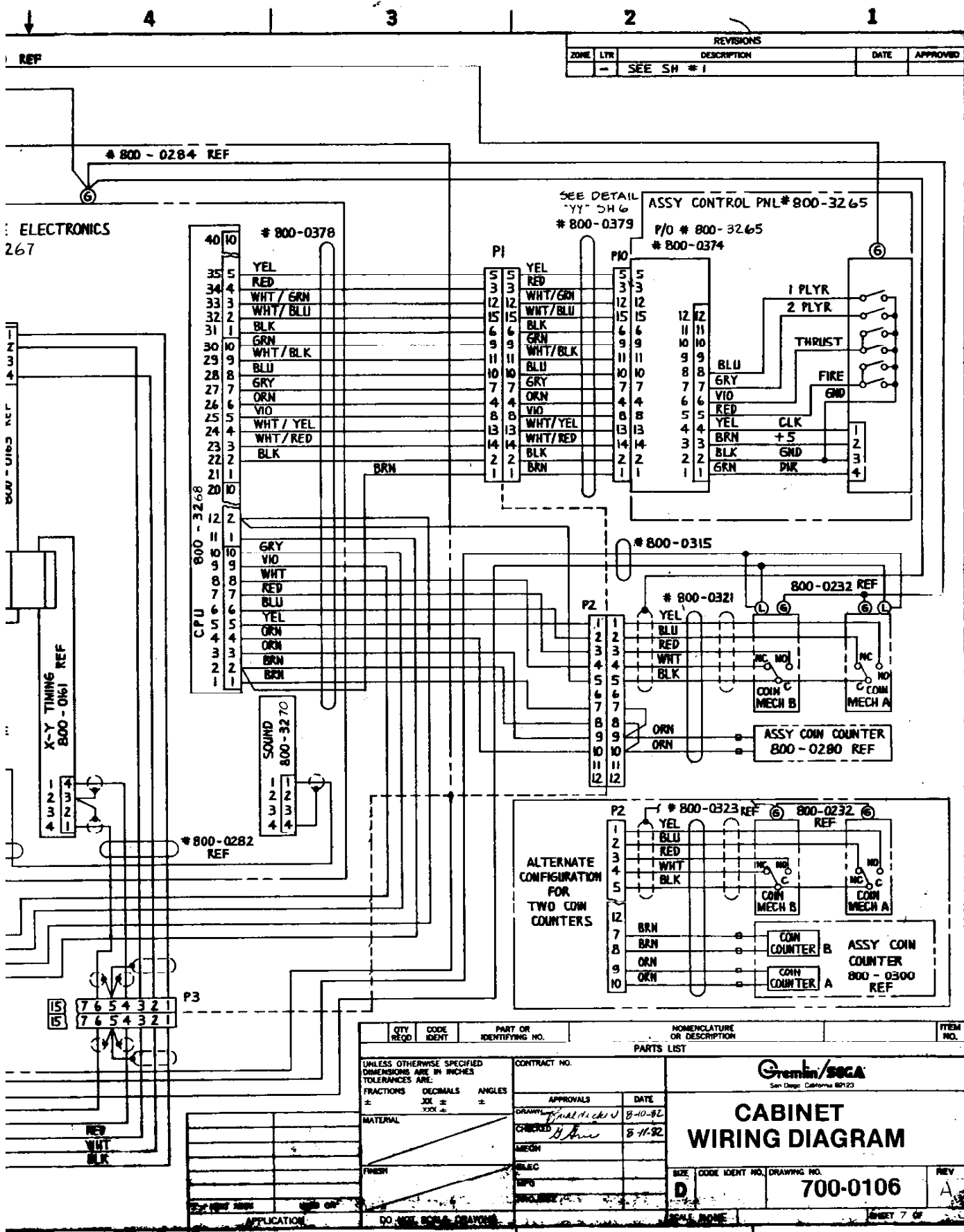

REVISIONS				
ZONE	LTR	DESCRIPTION	DATE	APPROVED
-	-	SEE SH #1		

QTY REQD	CODE IDENT	PART OR IDENTIFYING NO.	NOMENCLATURE OR DESCRIPTION	ITEM NO.
PARTS LIST				
UNLESS OTHERWISE SPECIFIED DIMENSIONS ARE IN INCHES TOLERANCES ARE:		CONTRACT NO.		
FRACTIONS ±	DECIMALS .XX ±	ANGLES ±	APPROVALS	
MATERIAL		DATE		
FINISH		DRAWN: <i>Paul Dickov</i> 8-10-82		
APPLICATION		CHECKED: <i>Blair</i> 5-11-82		
DO NOT SCALE DRAWING		MECH		
		ELEC		
		SPS		
		APPROVED		
		SIZE: D CODE IDENT NO. DRAWING NO. 700-0106 REV A		
		SHEET 7 OF		

**Gremban/BOGA**  
San Diego, California 92123

## CABINET WIRING DIAGRAM

700-0106

D  
C  
A  
700-0106

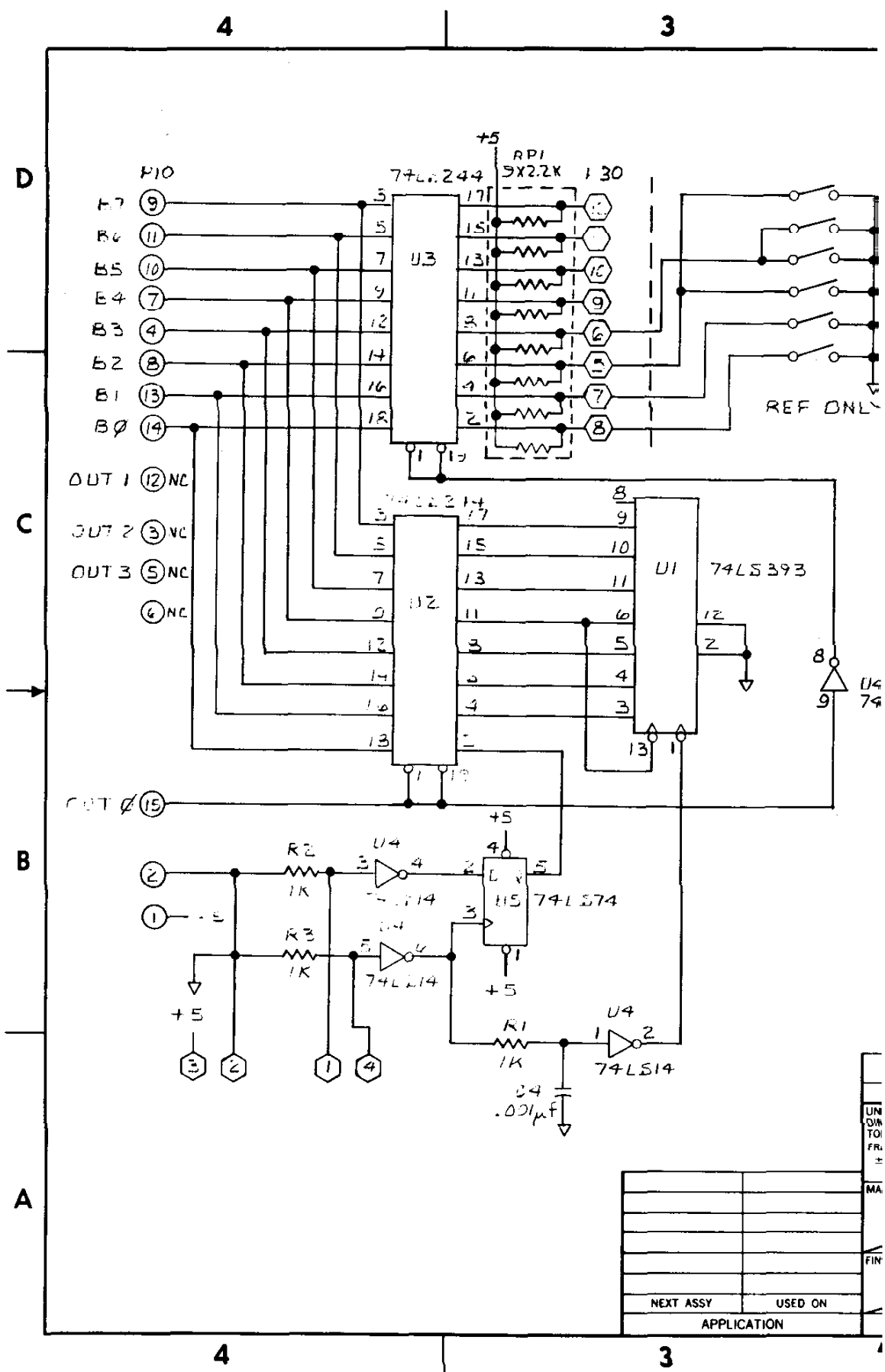

UN	TO	FR	±
MA			
FIN			
NEXT ASSY	USED ON		
APPLICATION			



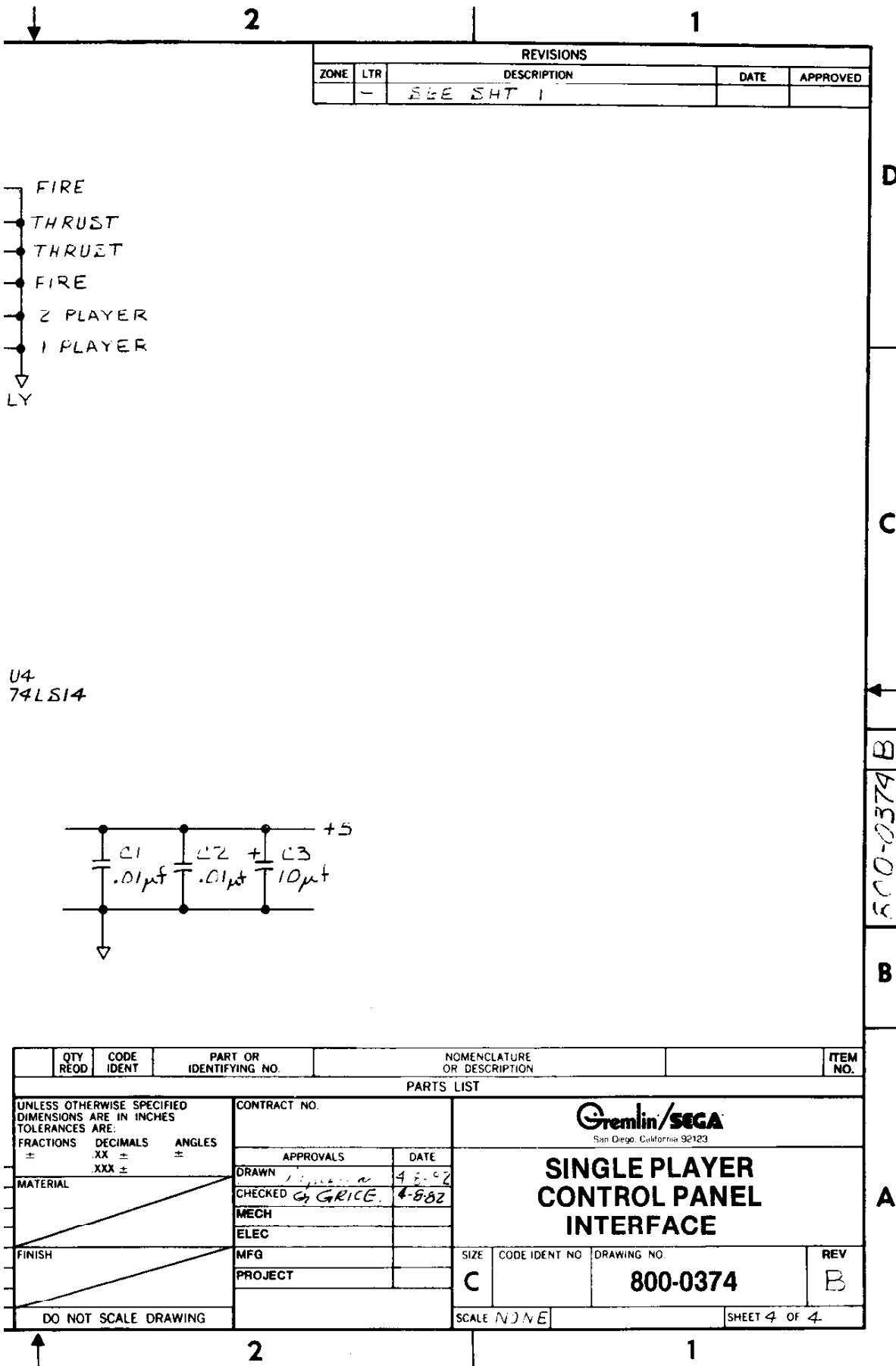

REVISIONS				
ZONE	LTR	DESCRIPTION	DATE	APPROVED
	-	SEE SHT 1		

FIRE  
 THRUST  
 THRUST  
 FIRE  
 2 PLAYER  
 1 PLAYER  
 LY

U4  
74LS14

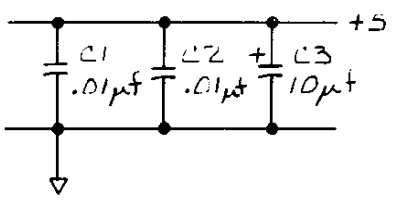

800-0374|B

QTY REQD	CODE IDENT	PART OR IDENTIFYING NO.	NOMENCLATURE OR DESCRIPTION	ITEM NO.
PARTS LIST				
UNLESS OTHERWISE SPECIFIED DIMENSIONS ARE IN INCHES TOLERANCES ARE: FRACTIONS ±    DECIMALS XX ±    ANGLES ± MATERIAL		CONTRACT NO. APPROVALS DRAWN <i>[Signature]</i> DATE 4-5-82 CHECKED <i>G. GRICE</i> 4-5-82 MECH ELEC	<b>Gremlin/SEGA</b> <small>San Diego, California 92123</small> <b>SINGLE PLAYER            CONTROL PANEL            INTERFACE</b>	
FINISH		MFG	SIZE C	CODE IDENT NO. 800-0374
DO NOT SCALE DRAWING		PROJECT	DRAWING NO. 800-0374	REV B
			SCALE NONE	SHEET 4 OF 4

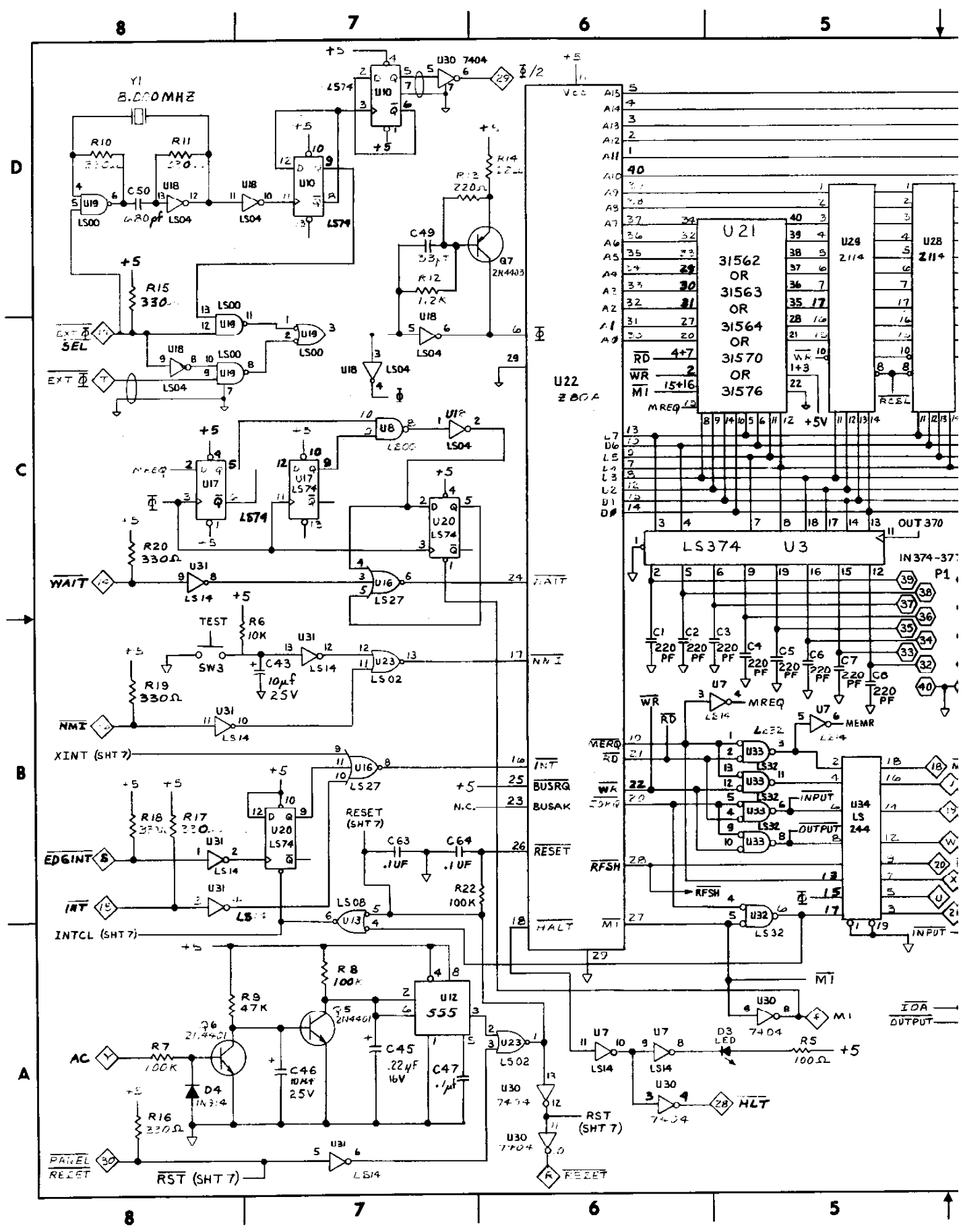

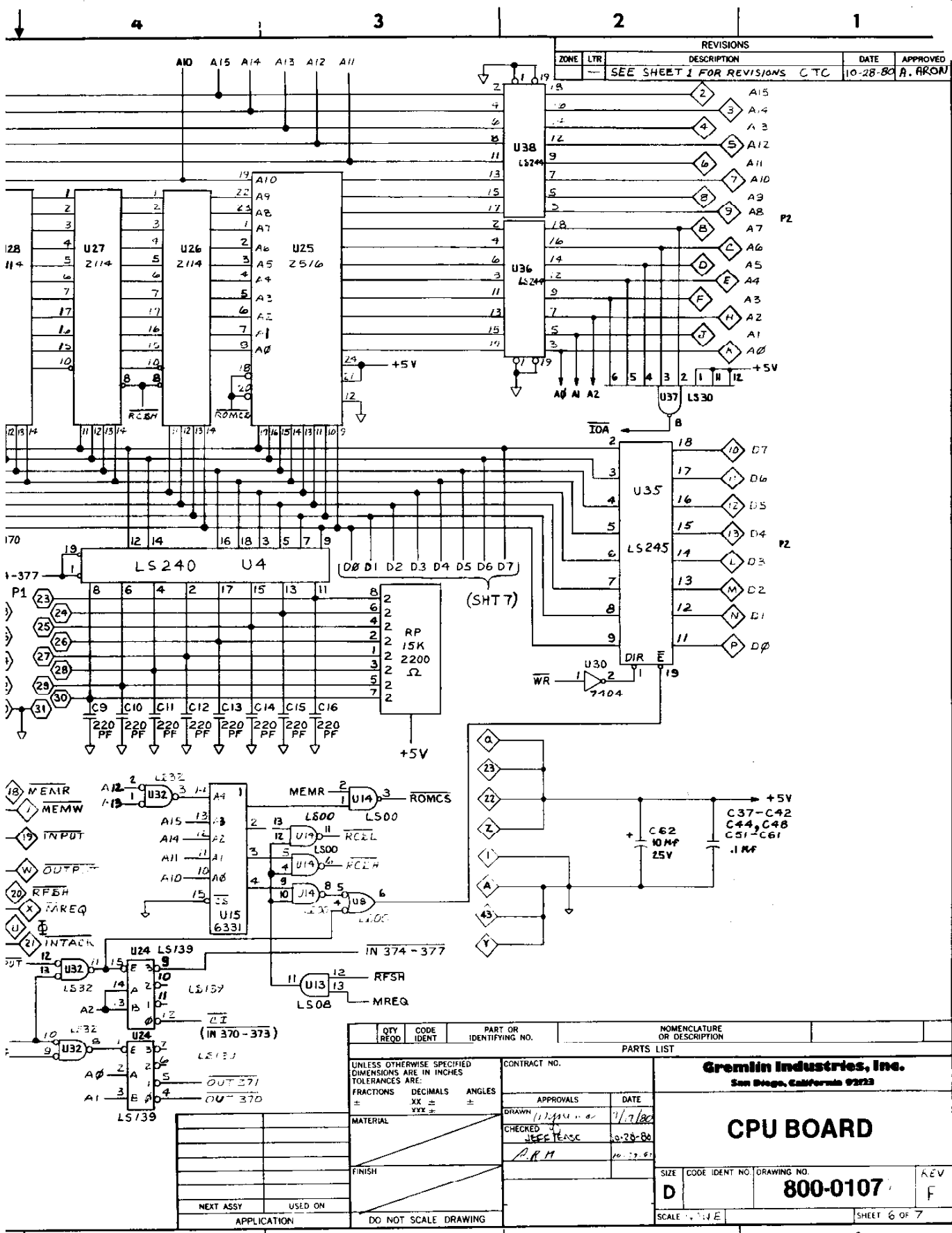

800-0107 F

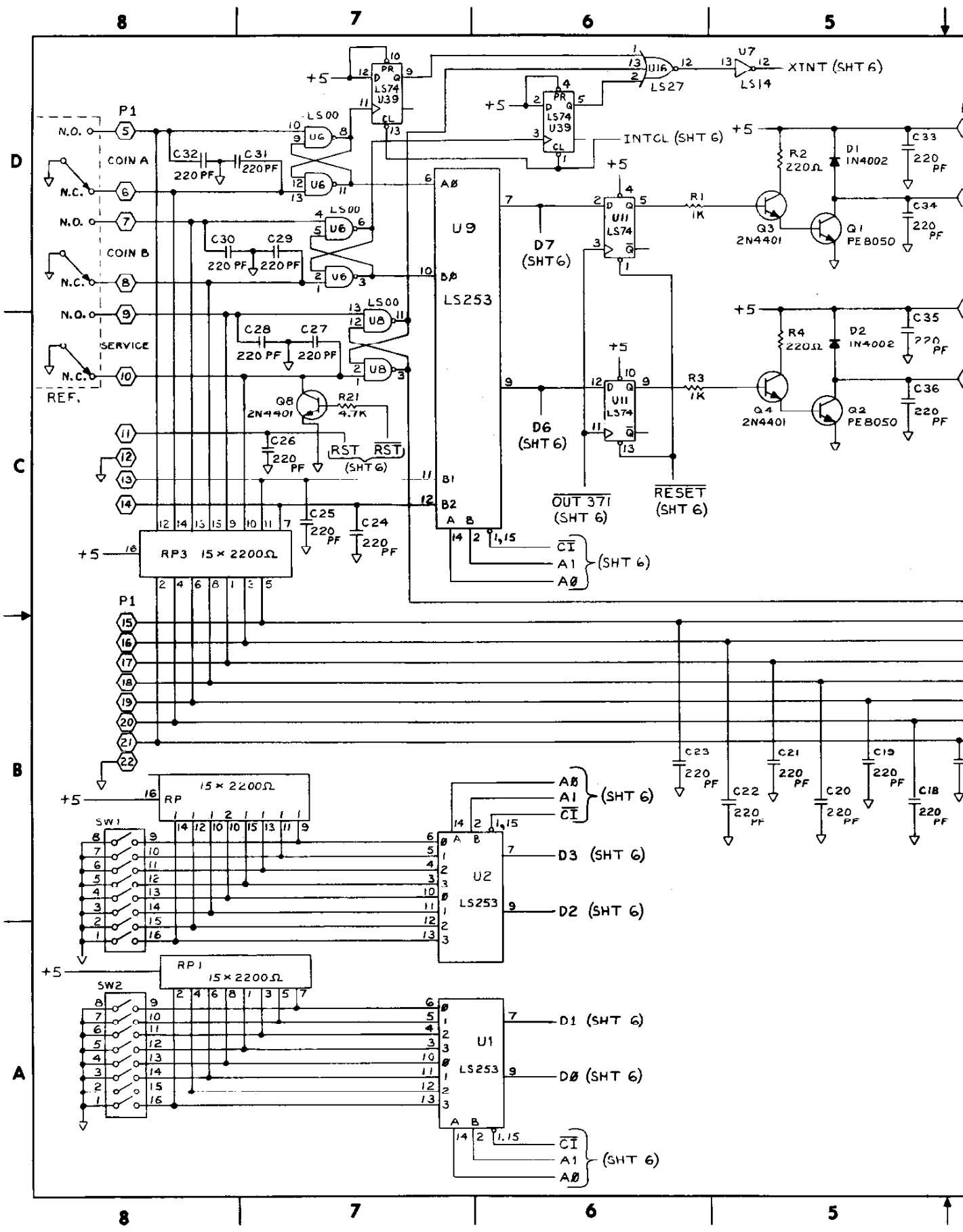

REVISIONS				
ZONE	LTR	DESCRIPTION	DATE	APPROVED
	A	RELEASED	CTC	10-28-80 A. ARON
	B	ECN # 528	CTC	11-13-80 JEFFREY
	C	ECN # 669	CTC	2-16-81 RH
	D	ECN # 677A	CTC	2-25-81 <del>ARM</del>
	E	PER ECN # 978	M.G.A.	8-31-81 G. HIGLER
		SEE SHT 1 FOR REV	WJB	

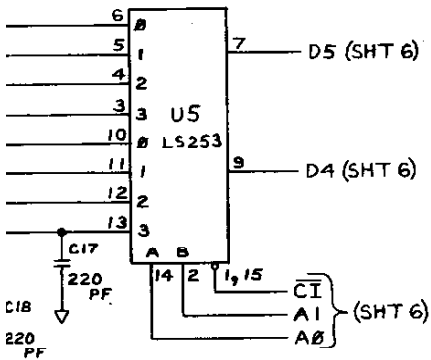

D  
C  
B  
F  
800-0107

QTY REQD	CODE IDENT	PART OR IDENTIFYING NO.	NOMENCLATURE OR DESCRIPTION
PARTS LIST			
UNLESS OTHERWISE SPECIFIED DIMENSIONS ARE IN INCHES TOLERANCES ARE: FRACTIONS    DECIMALS    ANGLES ±                    XX ±                    ° ±			CONTRACT NO.
MATERIAL			<b>Gremlin Industries, Inc.</b> San Diego, California 92133
FINISH			<b>CPU BOARD</b>
NEXT ASSY                      USED ON		APPROVALS                      DATE DRAWN C. T. CATTELL                      10-23-80 CHECKED JEFFREY                      10-28-80 ARM                                              10-29-80	SIZE    CODE IDENT NO.    DRAWING NO.    REV D                                              800-0107                      F
APPLICATION		DO NOT SCALE DRAWING	SCALE NONE                      SHEET 7 OF 7

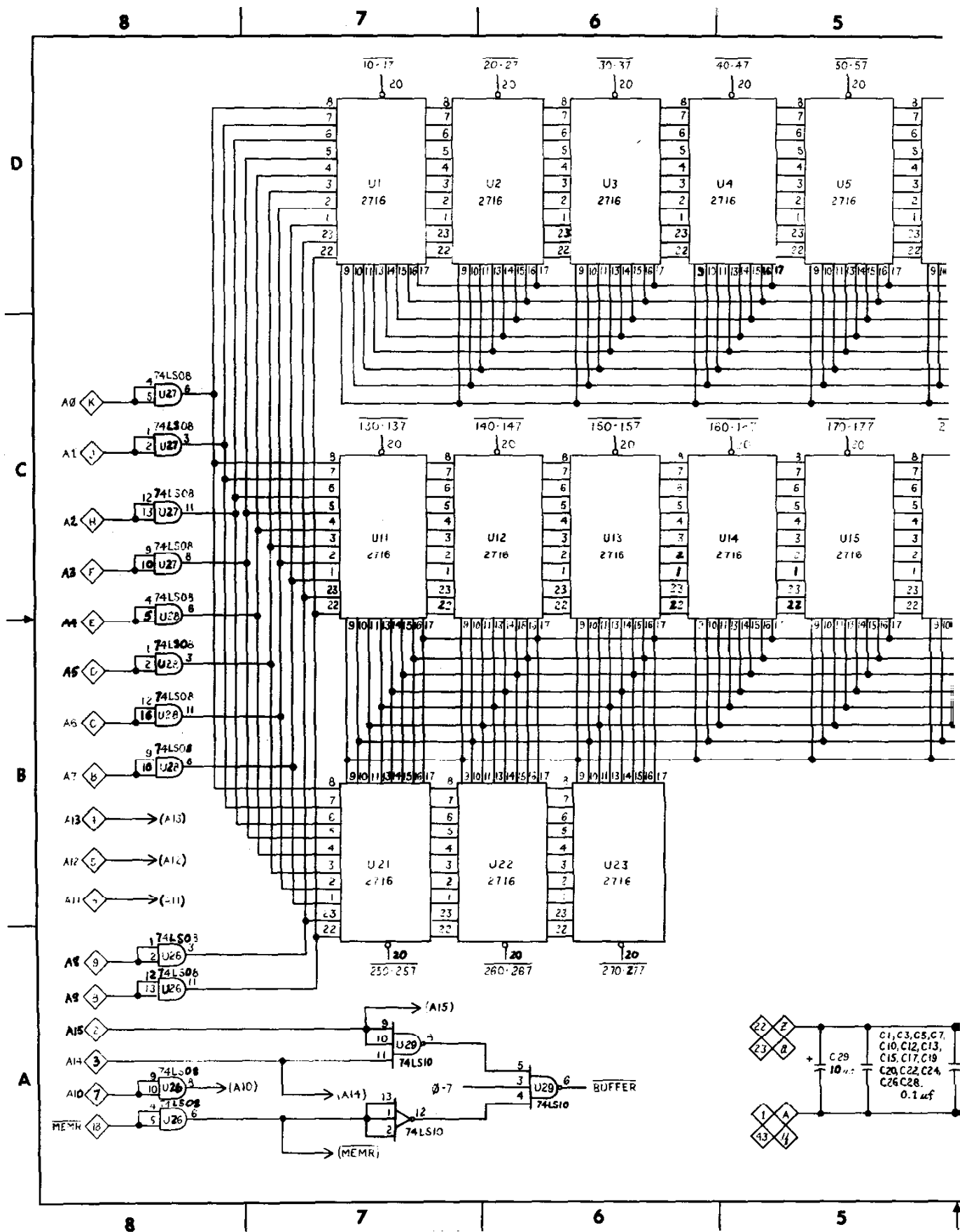

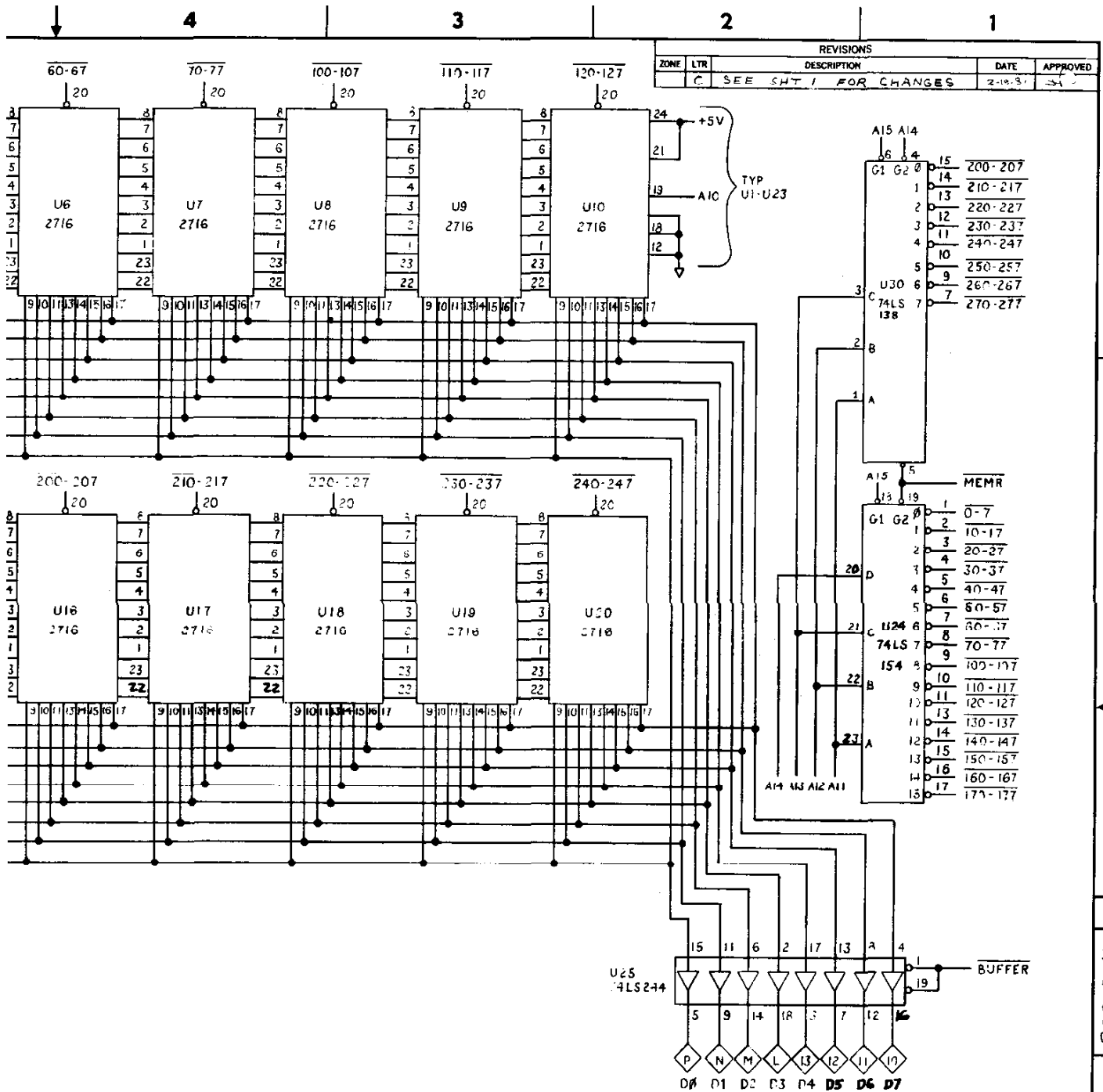

REVISIONS				
ZONE	LTR	DESCRIPTION	DATE	APPROVED
C		SEE SHT 1 FOR CHANGES	2-15-81	

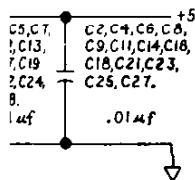

QTY REQD	CODE IDENT	PART OR IDENTIFYING NO.	NOMENCLATURE OR DESCRIPTION
PARTS LIST			
UNLESS OTHERWISE SPECIFIED DIMENSIONS ARE IN INCHES. TOLERANCES ARE:		CONTRACT NO.	
FRACTIONS	DECIMALS	ANGLES	APPROVALS
±	.XX ±	±	DATE
±	.XXX ±		
MATERIAL		DRAWN <i>Johnnie</i> (10/14/80)	
FINISH		CHECKED <i>L. M.</i> (10/22/80)	
NEXT ASSY		<b>Gremlin Industries, Inc.</b> San Diego, California 92123  <b>2716 EPROM BOARD</b>	
USED ON			
APPLICATION		SIZE	CODE IDENT NO.
		D	800-0151
DO NOT SCALE DRAWING		DRAWING NO.	REV
		SCALE NONE	SHEET 4 OF 4

800-0151 L

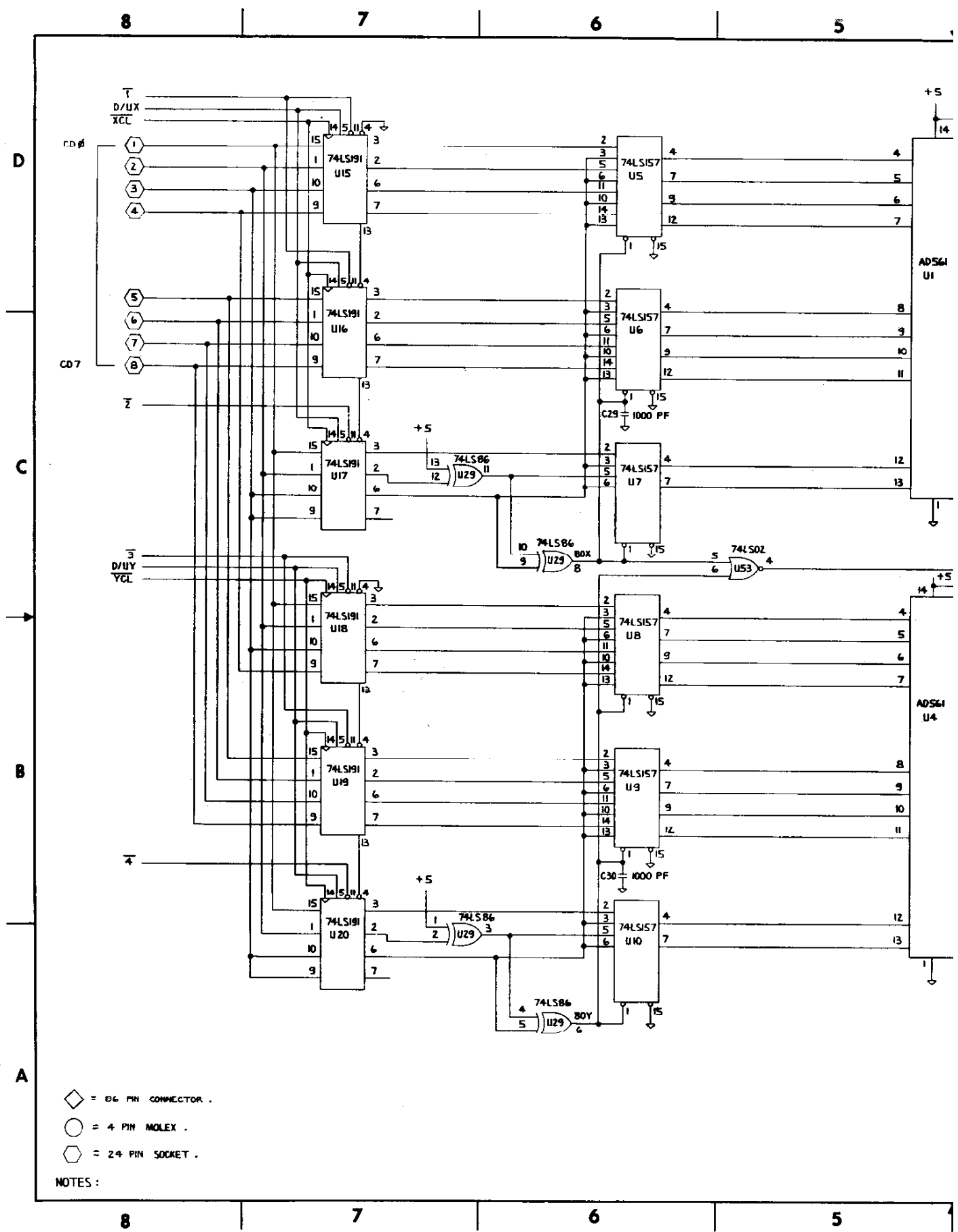

- ◇ = 24 PIN CONNECTOR .
- = 4 PIN MOLEX .
- ⬡ = 24 PIN SOCKET .

NOTES :

8 7 6 5

D  
C  
B  
A

8 7 6 5



REVISIONS				
ZONE	LTR	DESCRIPTION	DATE	APPROVED
		SEE SHY. 1	SD	

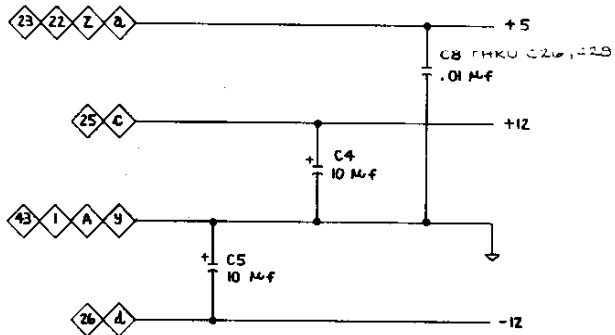
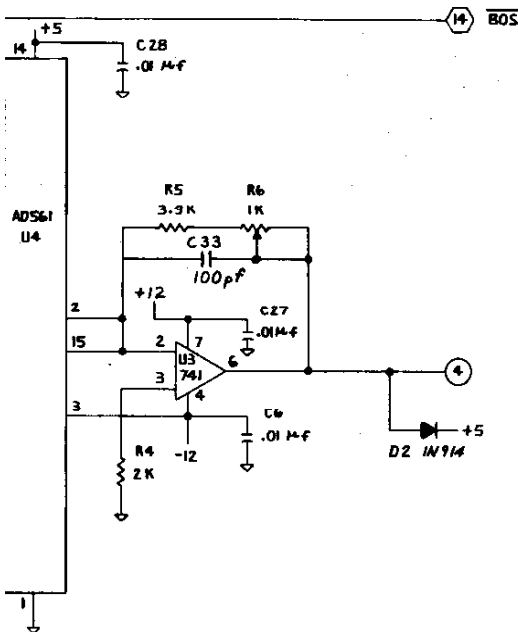
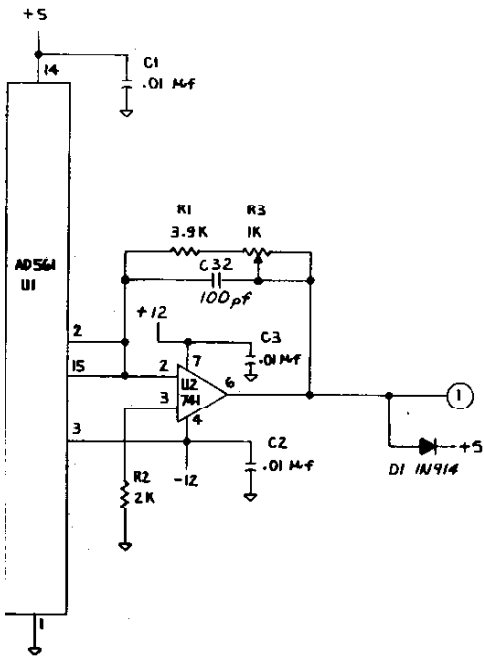

QTY REQD	CODE IDENT	PART OR IDENTIFYING NO.	NOMENCLATURE OR DESCRIPTION
PARTS LIST			
UNLESS OTHERWISE SPECIFIED DIMENSIONS ARE IN INCHES TOLERANCES ARE:		CONTRACT NO.	
FRACTIONS	DECIMALS	ANGLES	
±	.XX ±	±	
	.XXX ±		
MATERIAL		APPROVALS	DATE
		DRAWN SON DUONG	3-12-81
		CHECKED <i>[Signature]</i>	4-20-81
FINISH			
800-3155	700-0054		
NEXT ASSY	USED ON		
APPLICATION		DO NOT SCALE DRAWING	
		Gremlin Industries, Inc. San Diego, California 92123	
		<b>X-Y TIMING</b>	
SIZE	CODE IDENT NO.	DRAWING NO.	REV
D		800-0161	1
SCALE NONE		SHEET 5 OF 7	

D  
C  
B  
A  
800-0161

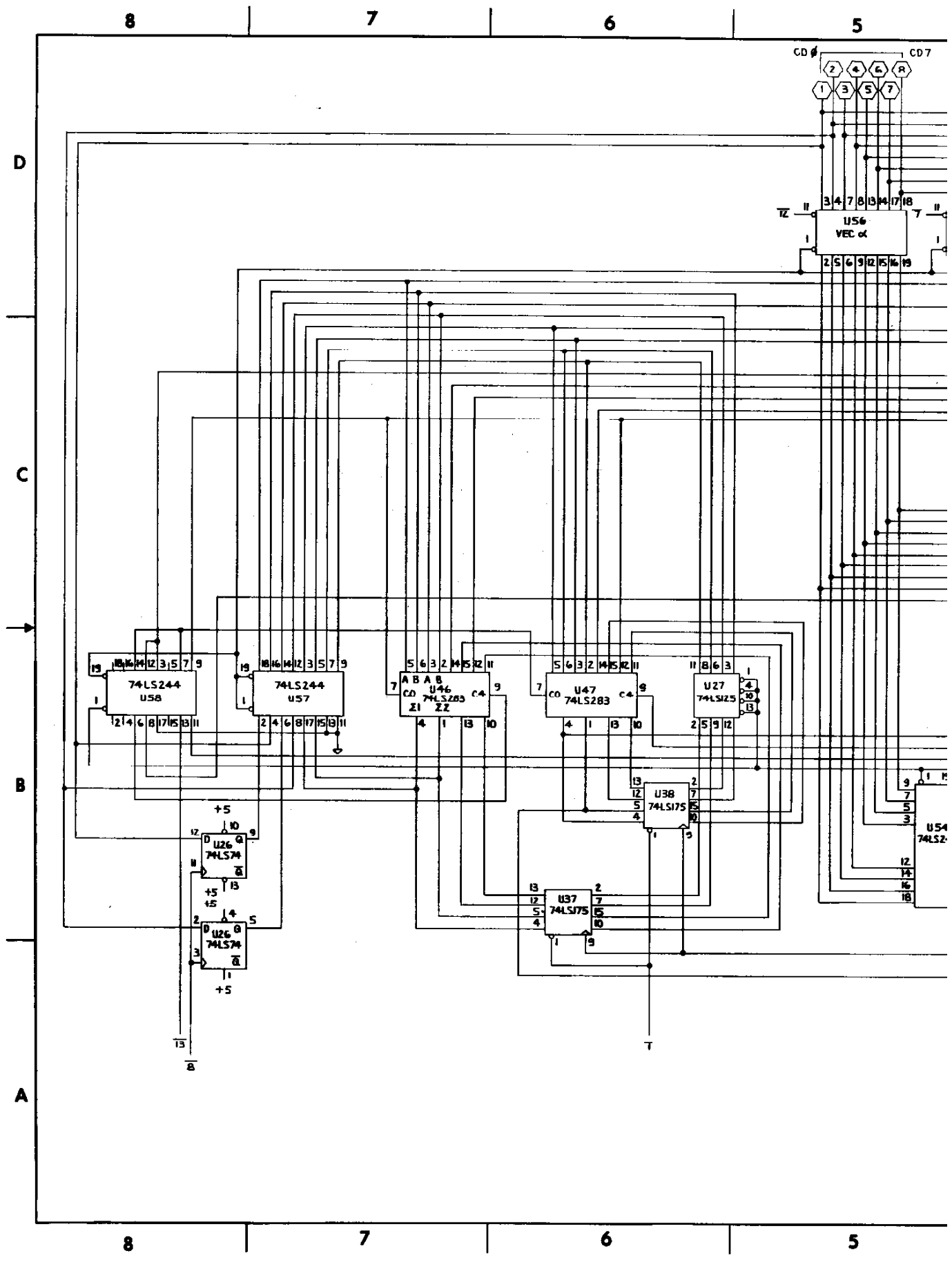

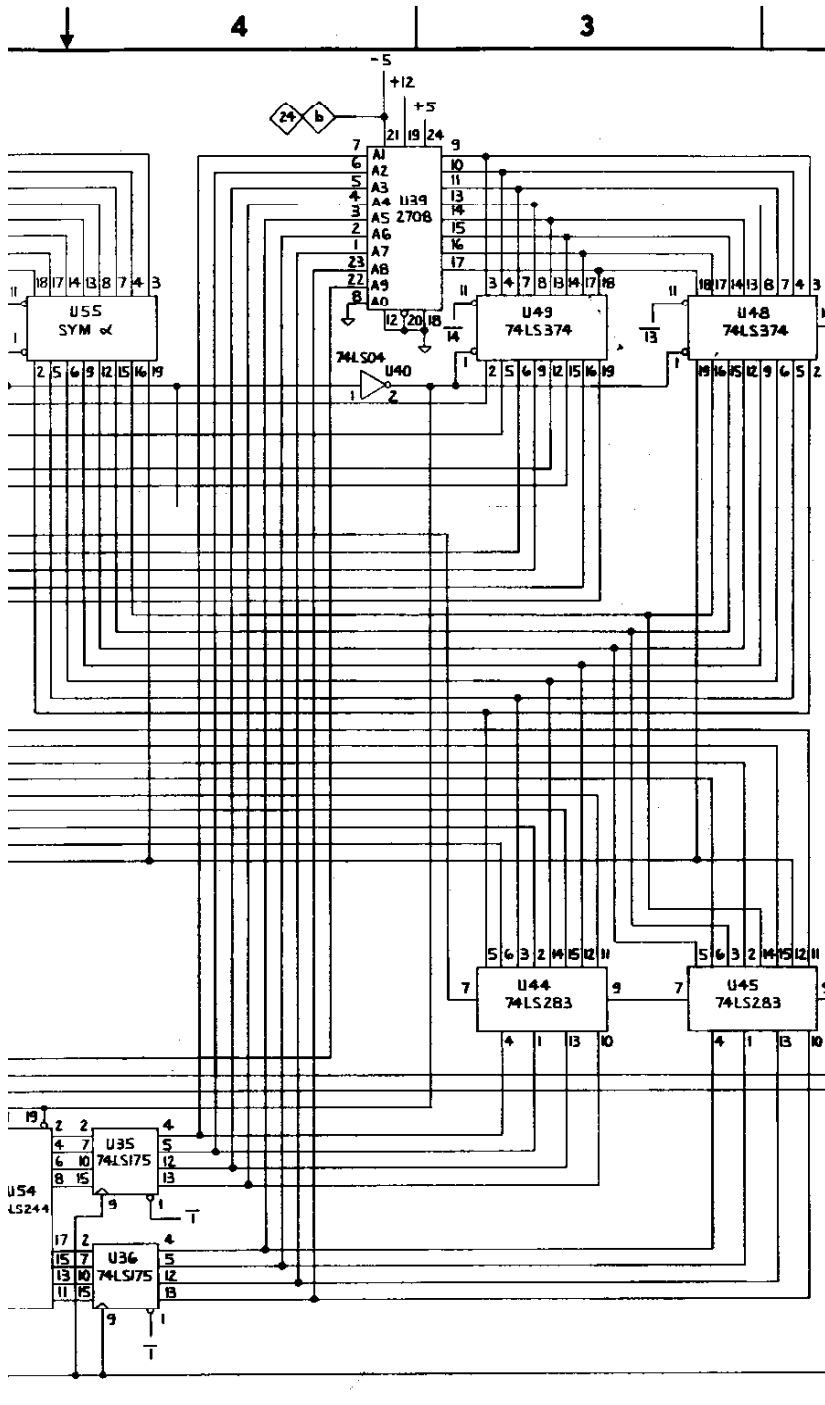

REVISIONS				
ZONE	LTR	DESCRIPTION	DATE	APPROVED
		SEE SHT. 1	SD	

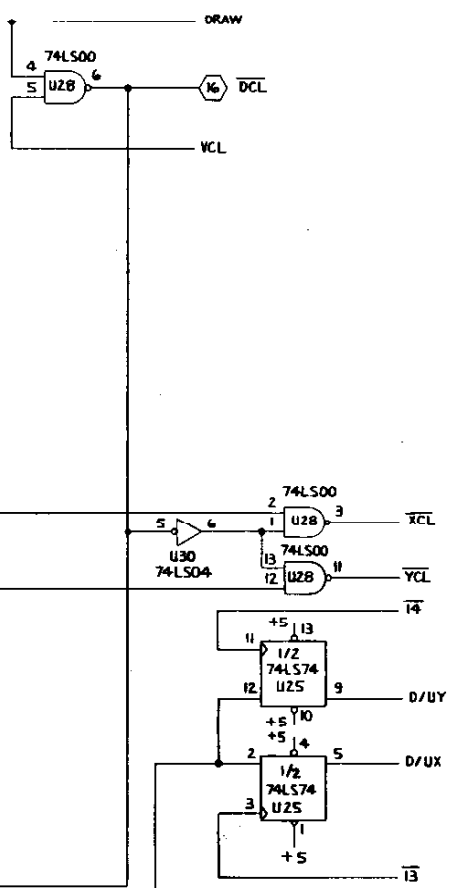

QTY REQD	CODE IDENT	PART OR IDENTIFYING NO.	NOMENCLATURE OR DESCRIPTION
PARTS LIST			
UNLESS OTHERWISE SPECIFIED DIMENSIONS ARE IN INCHES TOLERANCES ARE:		CONTRACT NO.	<b>Gremlin Industries, Inc.</b> San Diego, California 92123
FRACTIONS	DECIMALS	ANGLES	
±	.xx ±	±	<b>X-Y TIMING</b>
	.xxx ±		
MATERIAL		APPROVALS	DATE
		DRAWN SON DUONG	3-16-81
		CHECKED <i>[Signature]</i>	4-28-81
			9/2/81
FINISH		SIZE	CODE IDENT NO. DRAWING NO.
		D	800-0161
800-3155 700-0054		SCALE NONE	REV J
NEXT ASSY USED ON			SHEET 6 OF 7
APPLICATION		DO NOT SCALE DRAWING	

D  
C  
B  
A  
800-0161

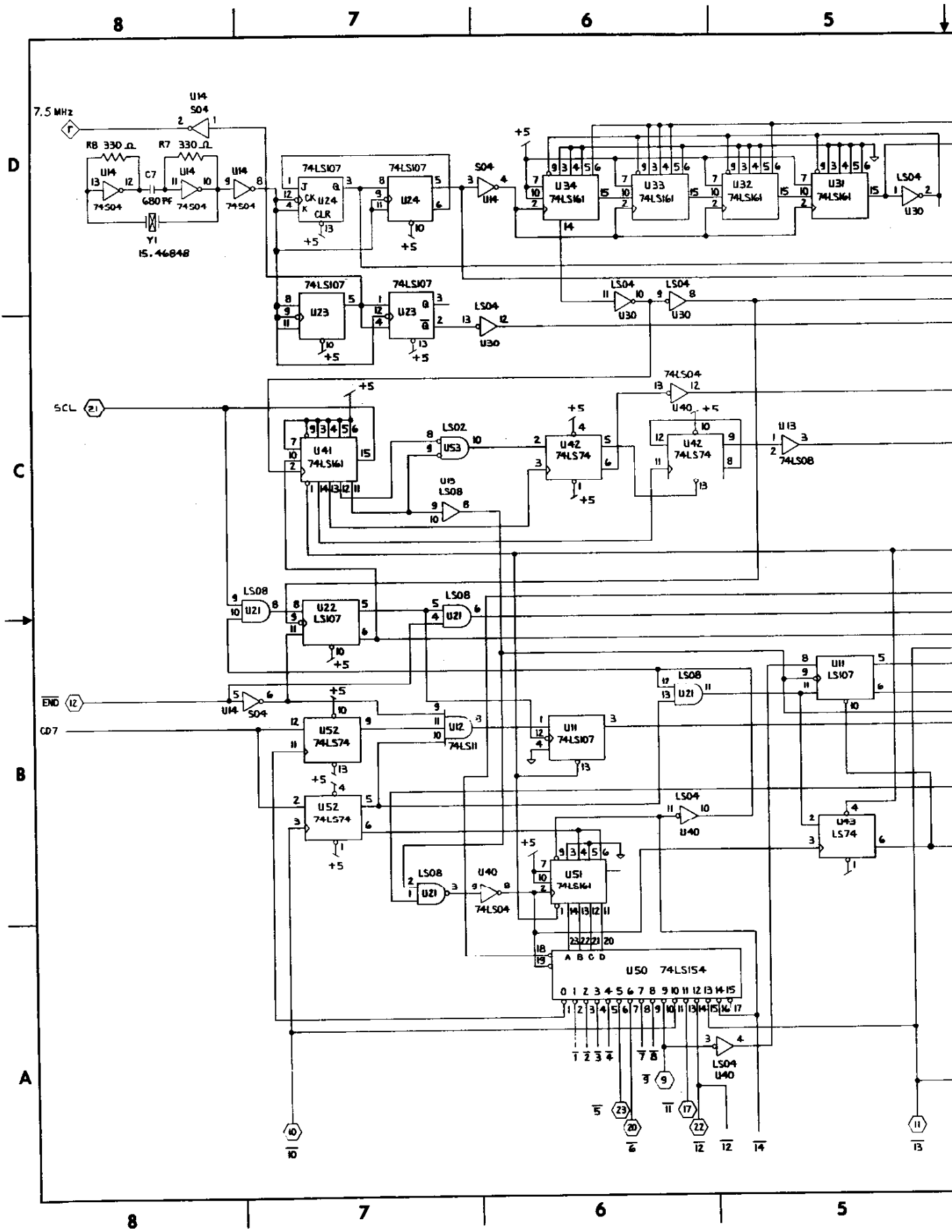

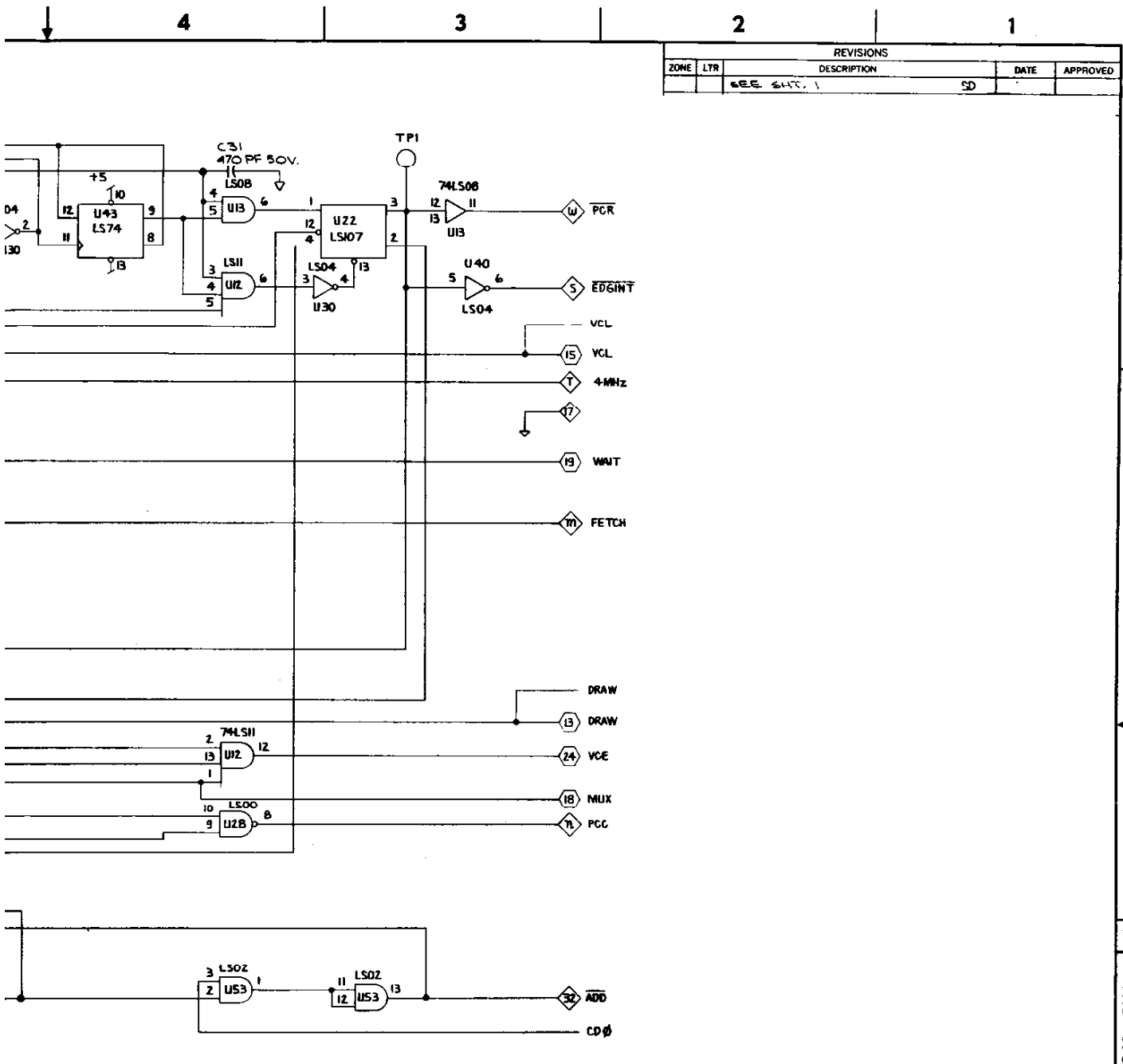

REVISIONS				
ZONE	LTR	DESCRIPTION	DATE	APPROVED
		SEE SHEET 1	SD	

D  
C  
B  
A

QTY	CODE	PART OR	NOMENCLATURE
REQD	IDENT	IDENTIFYING NO.	OR DESCRIPTION
PARTS LIST			
UNLESS OTHERWISE SPECIFIED DIMENSIONS ARE IN INCHES TOLERANCES ARE:		CONTRACT NO.	
FRACTIONS	DECIMALS	ANGLES	
±	XX ±	±	
±	XXX ±		
MATERIAL		APPROVALS	
		DRAWN <i>SOM DUONG</i> 10-14-80	
		CHECKED <i>JEFF PEASE</i> 11-6-80	
		<i>1/20/81</i>	
FINISH		DATE	
NEXT ASSY		SIZE	
700-0059		D	
USED ON		CODE IDENT NO.	
APPLICATION		DRAWING NO.	
DO NOT SCALE DRAWING		800-0161	
		REV	
		7	
		SCALE NONE	
		SHEET 7 OF 7	

A

800-0161

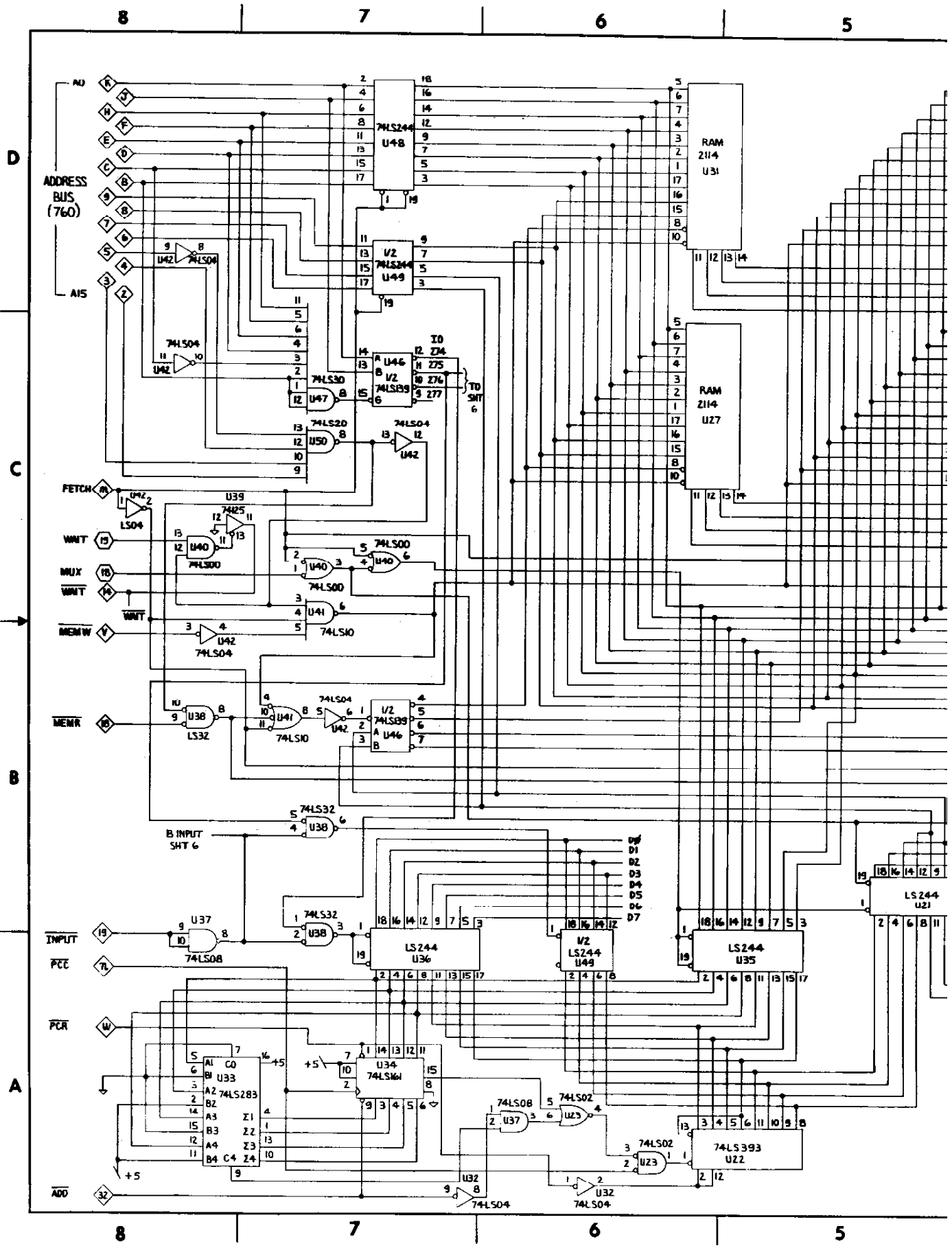

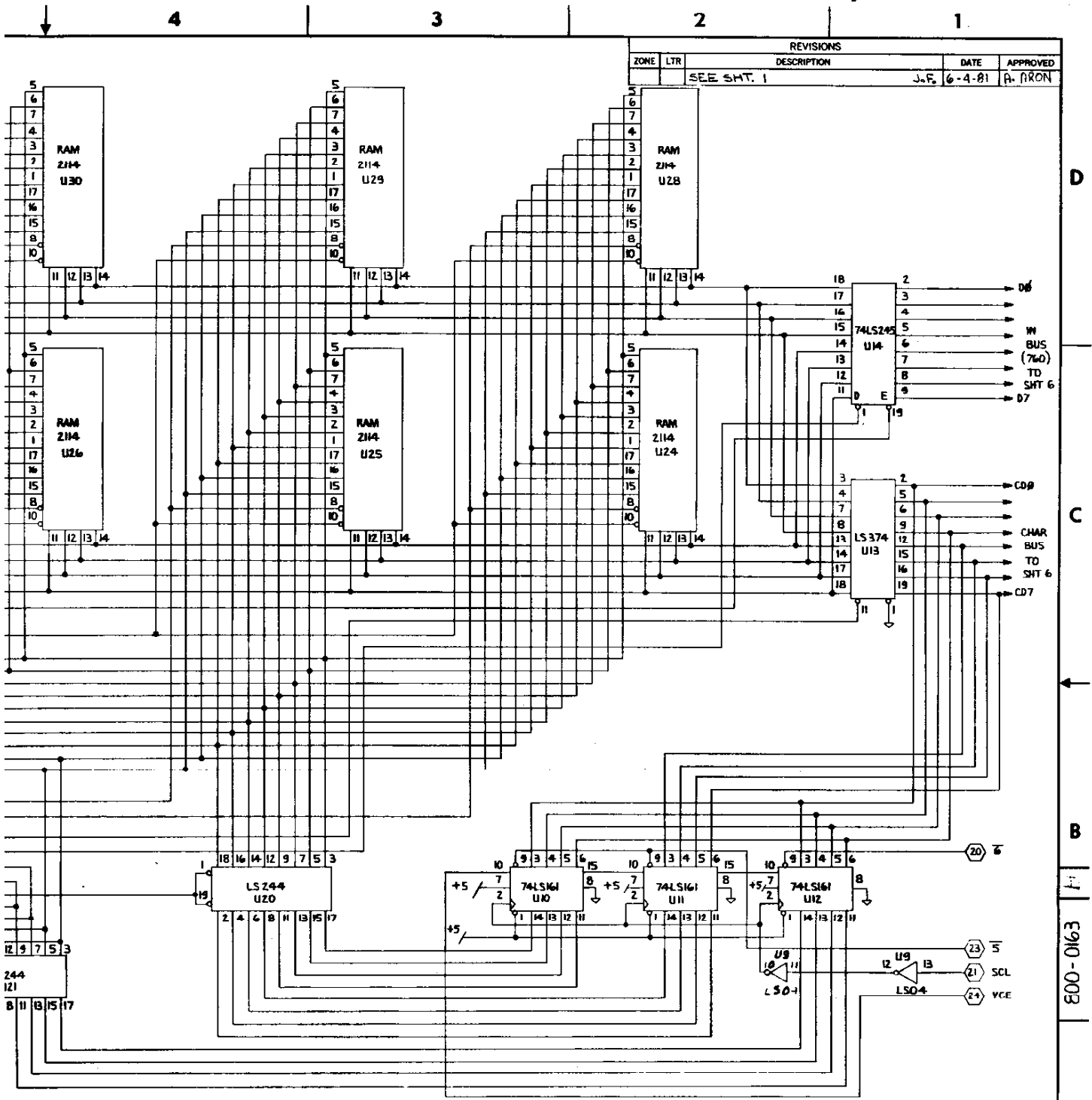

REVISIONS				
ZONE	LTR	DESCRIPTION	DATE	APPROVED
		SEE SHT. 1	J.F. 6-4-81	A. ARON

QTY	CODE	PART OR	NOMENCLATURE
REQD	IDENT	IDENTIFYING NO.	OR DESCRIPTION
PARTS LIST			
UNLESS OTHERWISE SPECIFIED DIMENSIONS ARE IN INCHES TOLERANCES ARE:		CONTRACT NO.	
FRACTIONS	DECIMALS	ANGLES	
±	.XX ±	±	
±	.XXX ±	±	
MATERIAL		APPROVALS	
		DATE	
		DRAWN SON DUONG 10-6-80	
		CHECKED JEFF PEARCE 11-3-80	
		APPROVED [Signature] 1/16/81	
FINISH		SIZE	
		CODE IDENT NO.	
		DRAWING NO.	
		REV	
800-3155 700-0054		D	
NEXT ASSY USED ON		800-0163	
APPLICATION		SCALE NONE	
DO NOT SCALE DRAWING		SHEET 5 OF 6	

**Gremlin Industries, Inc.**  
San Diego, California 92123

# X-Y CONTROL

800-0163

D  
C  
B  
A

800-0163

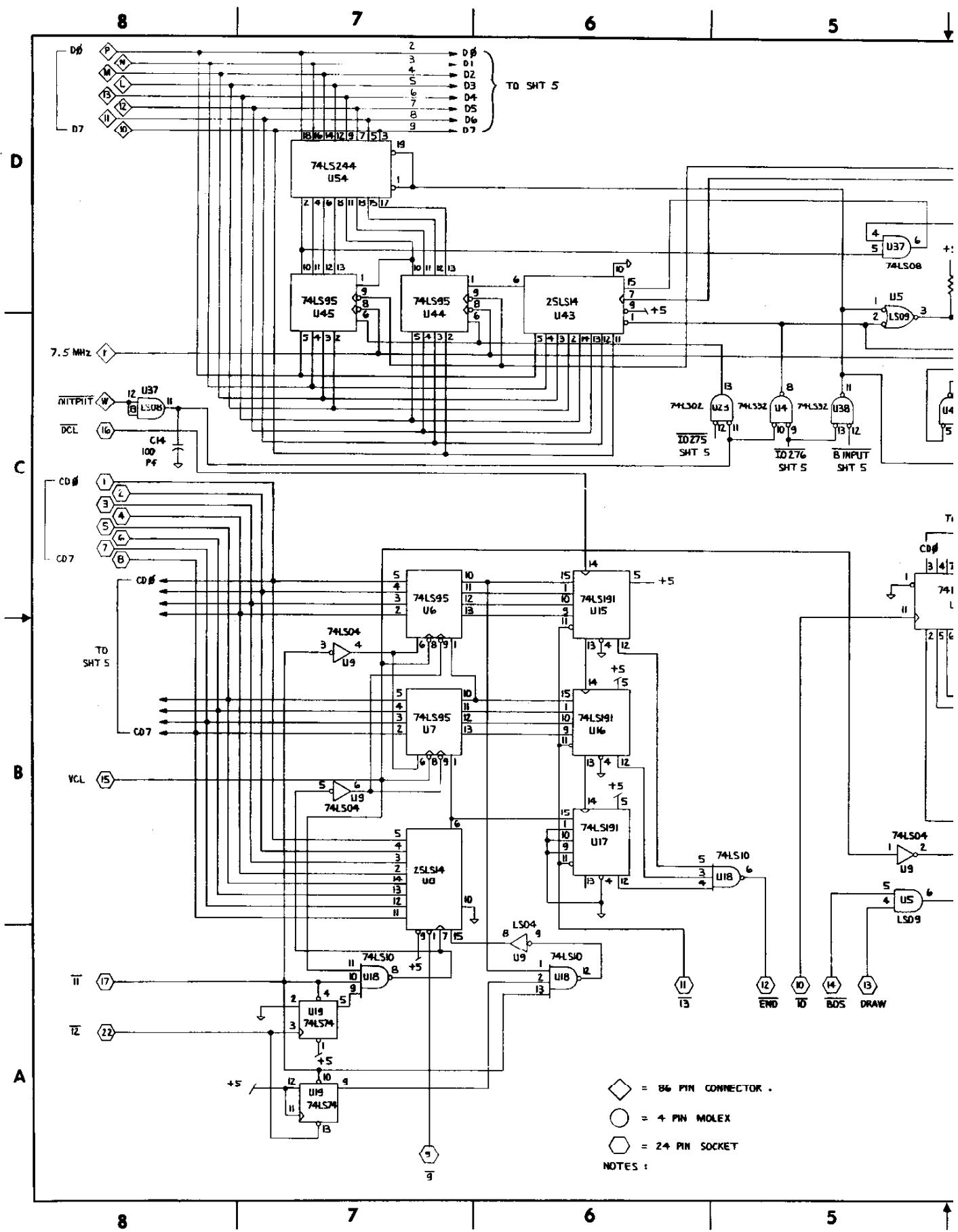

◇ = 86 PIN CONNECTOR .  
 ○ = 4 PIN MOLEX  
 ◻ = 24 PIN SOCKET  
 NOTES :



4		3		2		1	
REVISIONS							
ZONE	LTR	DESCRIPTION				DATE	APPROVED
		SEE SHT. 1				J.F. 6-4-81	G. ARON

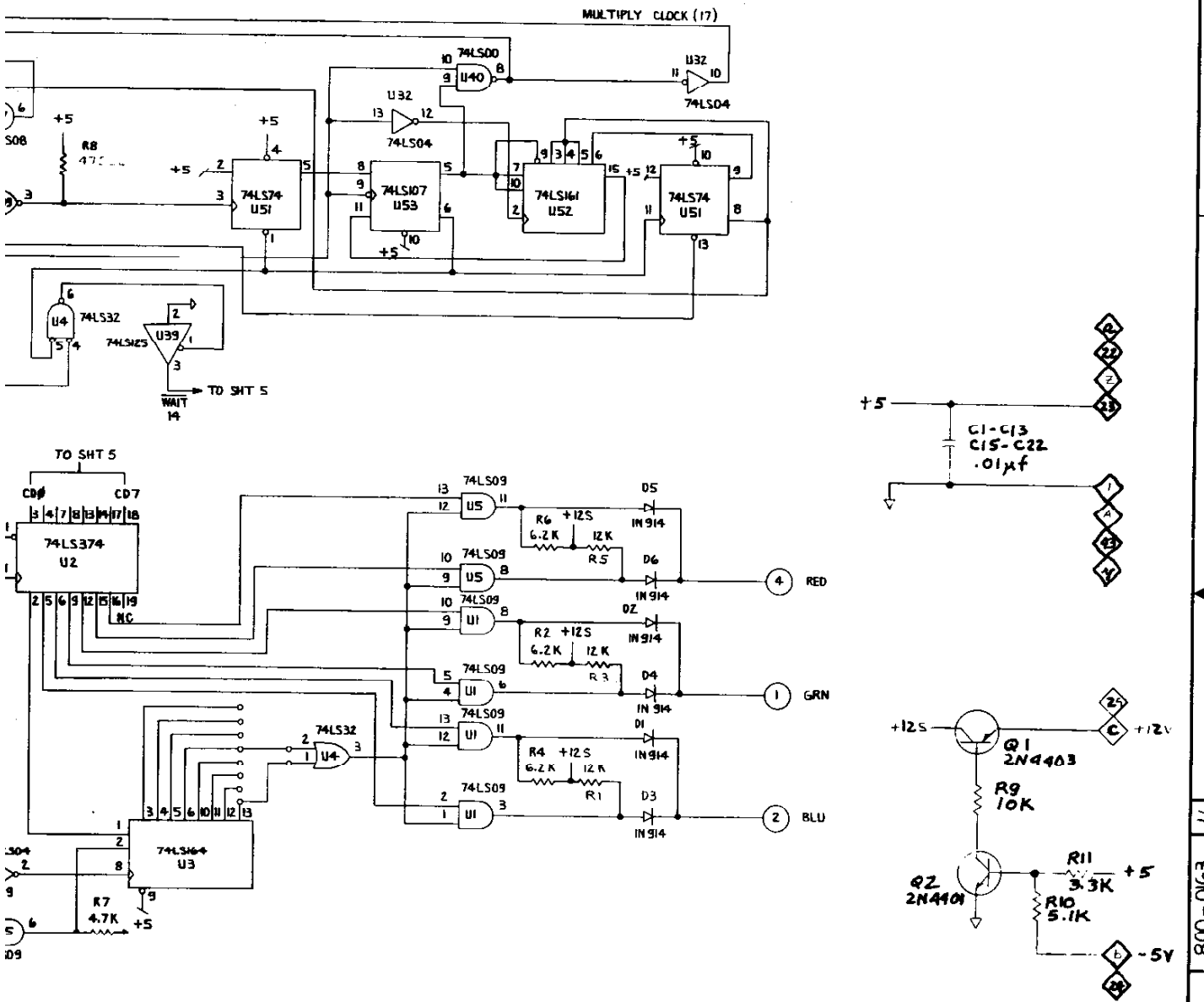

QTY REQD	CODE IDENT	PART OR IDENTIFYING NO.	NOMENCLATURE OR DESCRIPTION
PARTS LIST			
UNLESS OTHERWISE SPECIFIED DIMENSIONS ARE IN INCHES TOLERANCES ARE:		CONTRACT NO.	
FRACTIONS	DECIMALS	ANGLES	
+	.XX ±	±	
	.XXX ±		
MATERIAL		APPROVALS	
		DATE	
		DRAWN SON DUONG 10-8-80	
		CHECKED JEFF PASE 11-3-80	
		APPROVED [Signature] 11/11	
FINISH		Gremlin Industries, Inc.	
		San Diego, California 92123	
<b>X-Y CONTROL</b>			
SIZE	CODE IDENT NO	DRAWING NO.	REV
D		800-0163	P1
SCALE NONE		SHEET 6 OF 6	

4		3		2		1	
APPLICATION		DO NOT SCALE DRAWING		SCALE NONE		SHEET 6 OF 6	

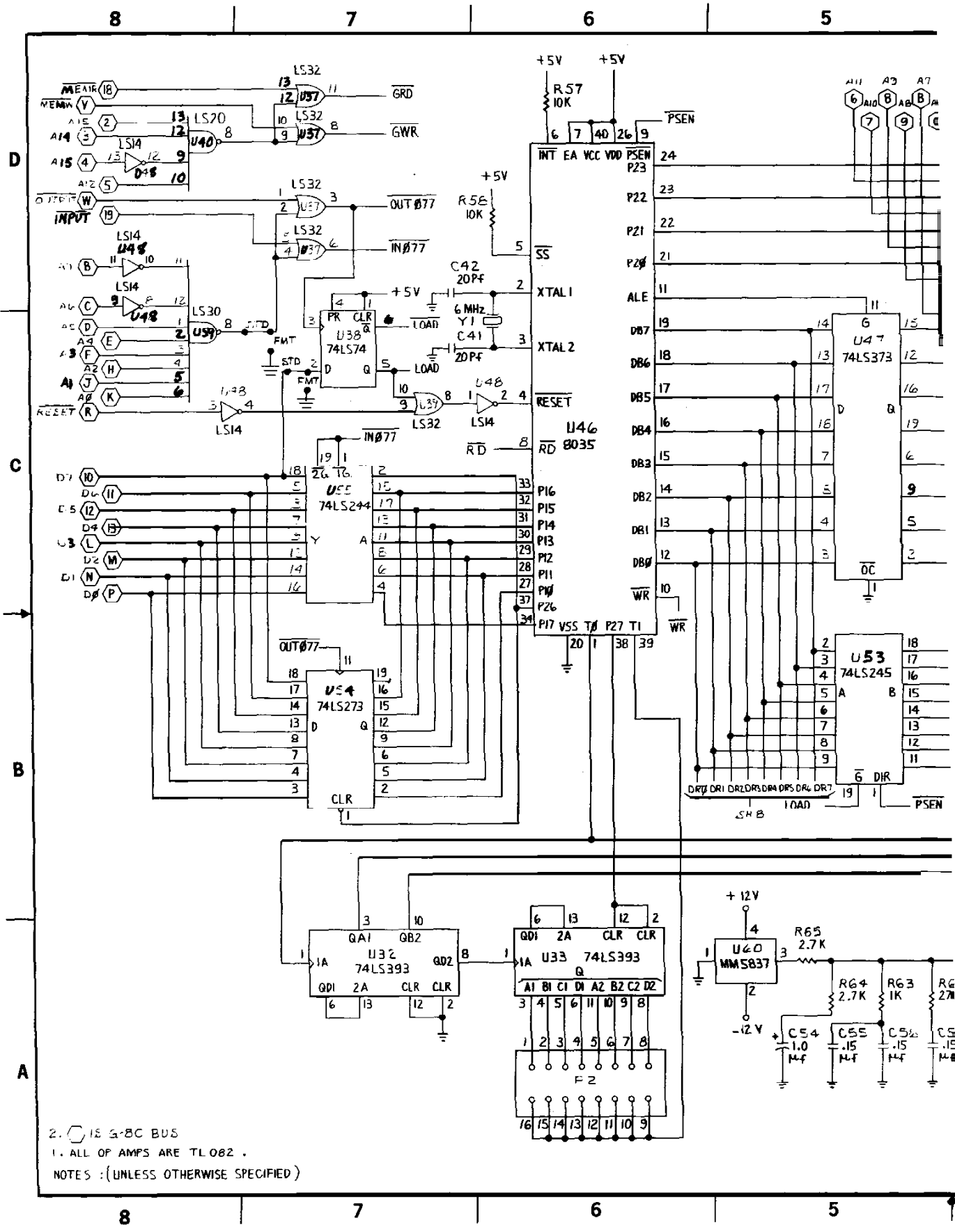

2.  $\square$  IS 3-BC BUS  
 1. ALL OF AMPS ARE TL082.  
 NOTES: (UNLESS OTHERWISE SPECIFIED)

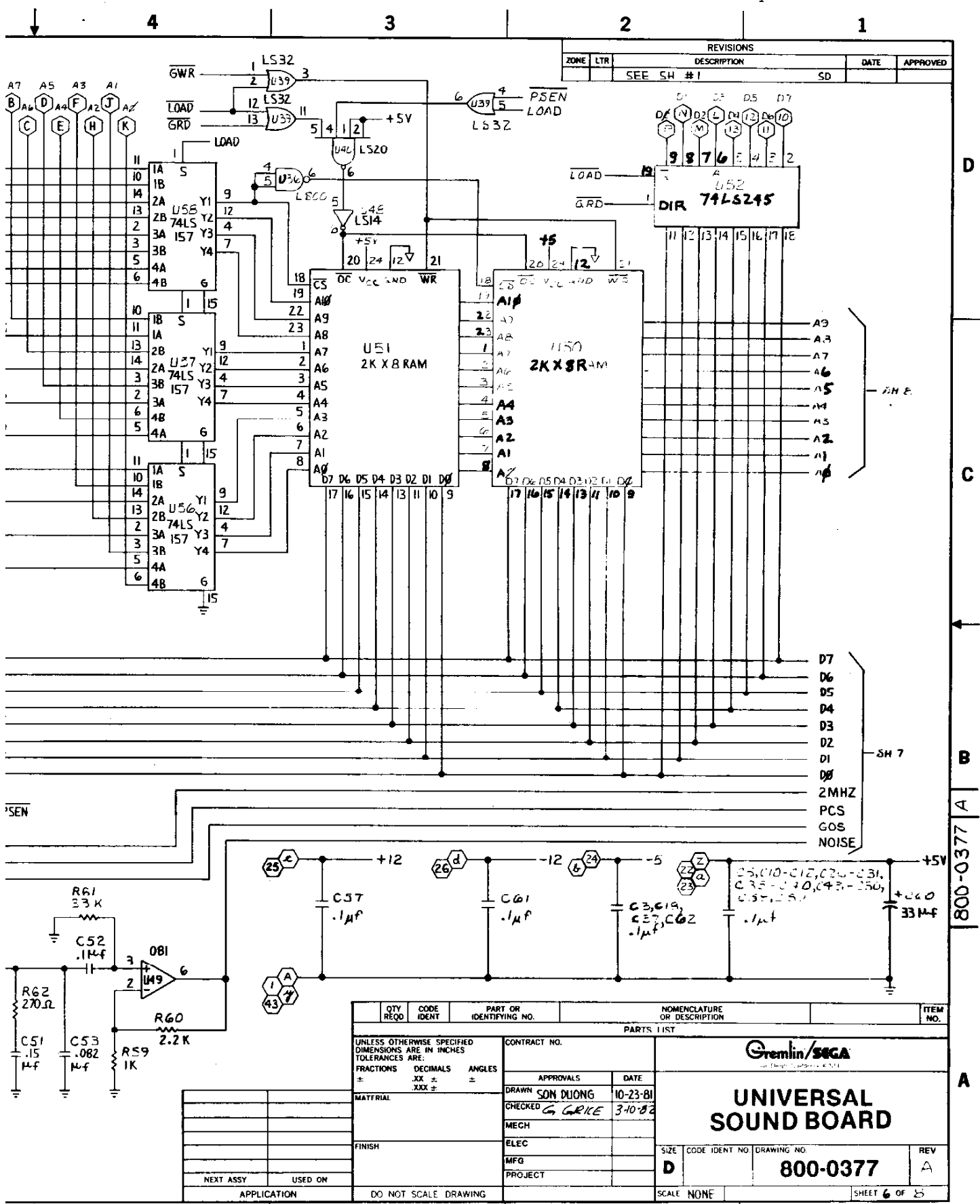

REVISIONS				
ZONE	LTR	DESCRIPTION	DATE	APPROVED
		SEE SH #1	SD	

D  
 C  
 B  
 A  
 800-0377 A  
 A

QTY REQD	CODE IDENT	PART OR IDENTIFYING NO.	NOMENCLATURE OR DESCRIPTION	ITEM NO.
PARTS LIST				
UNLESS OTHERWISE SPECIFIED DIMENSIONS ARE IN INCHES TOLERANCES ARE:		CONTRACT NO.	<b>Gremlin/SEGA</b> An Sega Company 4701 <b>UNIVERSAL SOUND BOARD</b>	
FRACTIONS	DECIMALS	ANGLES		
±	±	±		
±	±	±		
MATERIAL		APPROVALS	DATE	
		DRAWN SON DUONG	10-23-81	
		CHECKED G. GRIKE	3-10-82	
FINISH		MECH		
		ELEC		
		MFG		
		PROJECT		
NEXT ASSY	USED ON	SIZE	CODE IDENT NO. DRAWING NO.	REV
		D	800-0377	A
APPLICATION	DO NOT SCALE DRAWING	SCALE	NONE	SHEET 6 OF 8

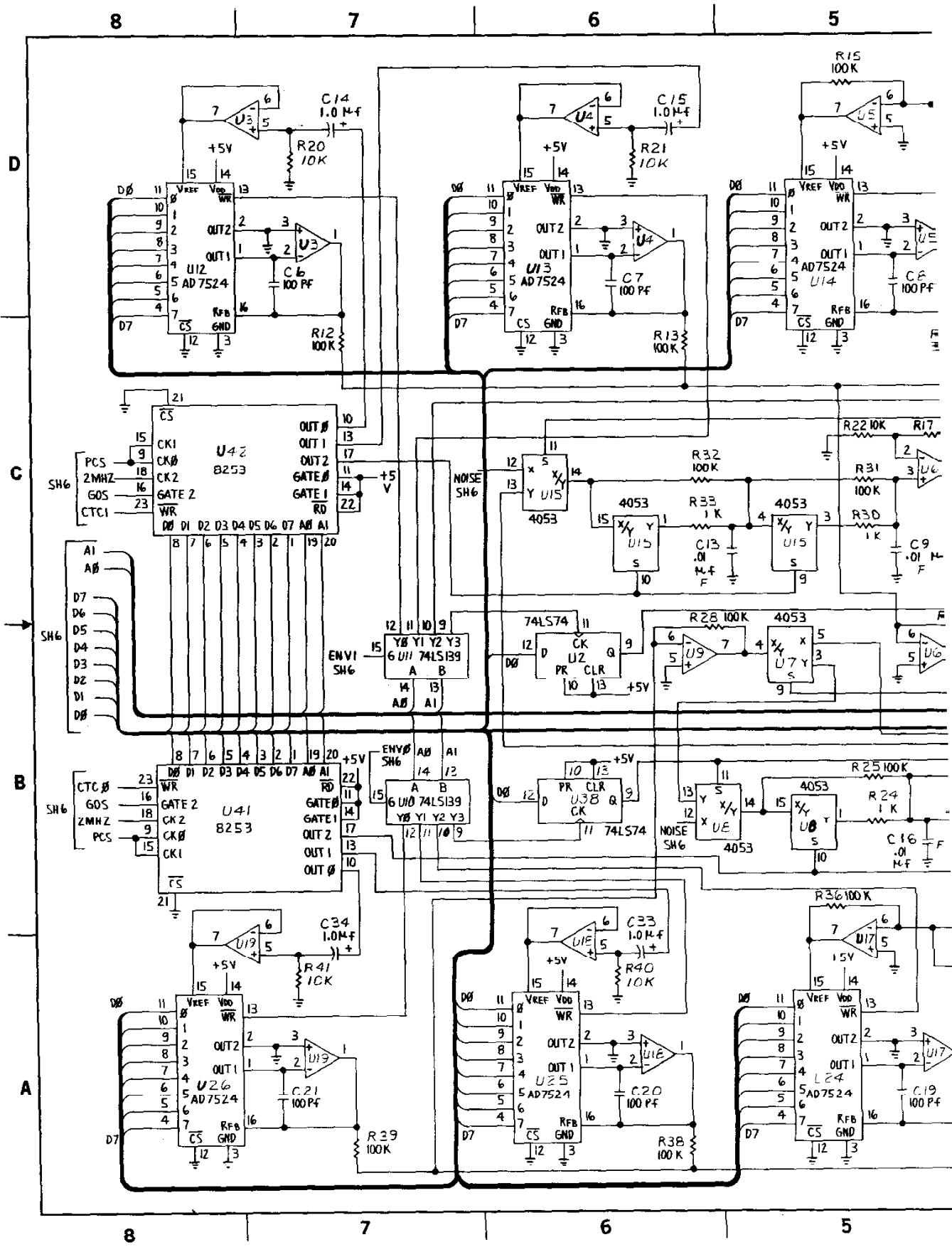

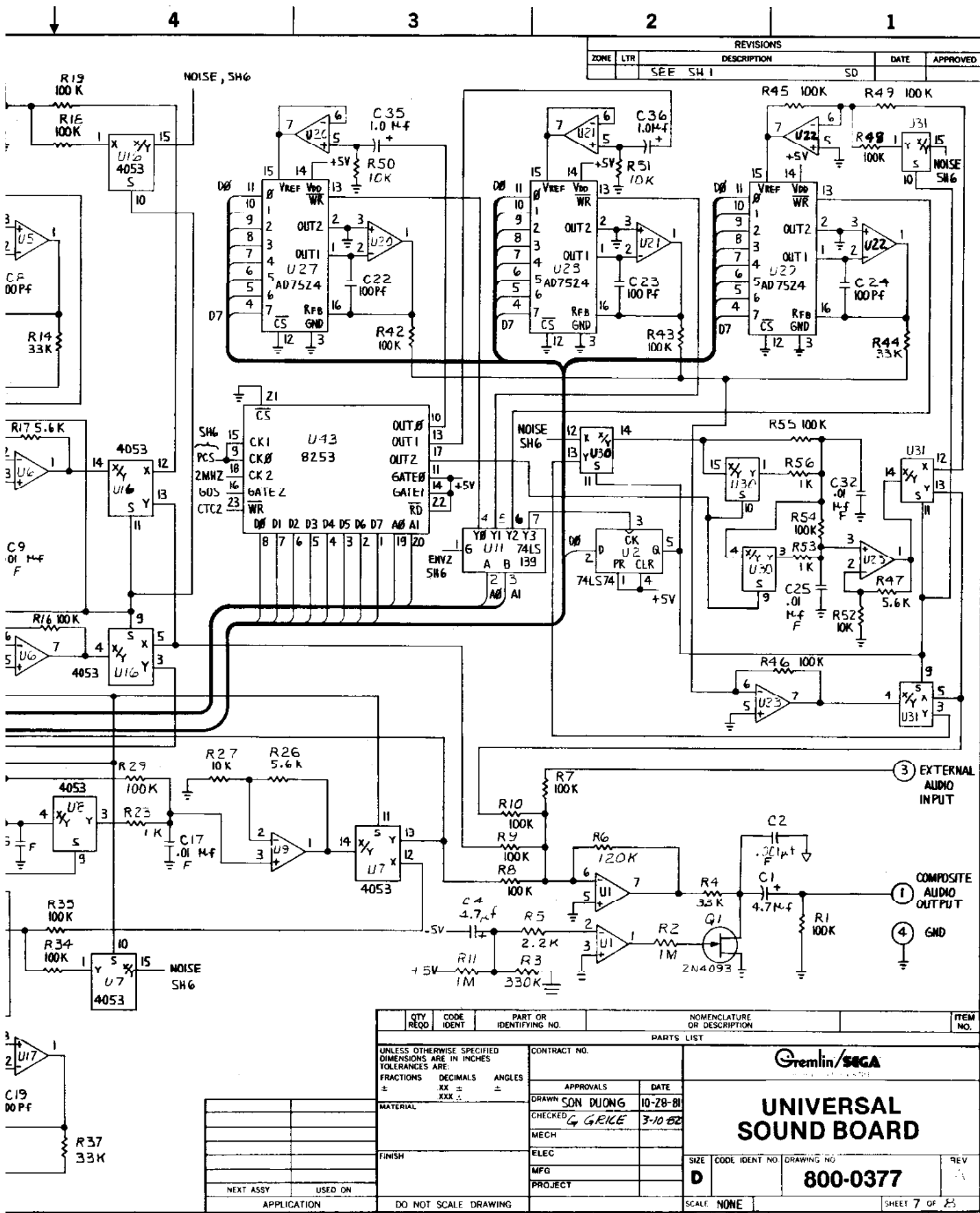

REVISIONS				
ZONE	LTR	DESCRIPTION	DATE	APPROVED
		SEE SH 1	SD	

D  
 C  
 B  
 A  
 800-0377

QTY REQD	CODE IDENT	PART OR IDENTIFYING NO.	NOMENCLATURE OR DESCRIPTION	ITEM NO.
PARTS LIST				
UNLESS OTHERWISE SPECIFIED DIMENSIONS ARE IN INCHES TOLERANCES ARE:		CONTRACT NO.		
FRACTIONS	DECIMALS	ANGLES		
±	±	±		
MATERIAL		APPROVALS		
FINISH		DATE		
NEXT ASSY		DRAWN SON DUONG 10-28-81		
USED ON		CHECKED G. GRICE 3-10-82		
APPLICATION		MECH		
DO NOT SCALE DRAWING		ELEC		
		MFG		
		PROJECT		
<h2 style="text-align: center;">UNIVERSAL SOUND BOARD</h2>				
SIZE CODE IDENT NO. DRAWING NO.				REV
<b style="font-size: 1.2em;">800-0377</b>				
SCALE NONE				SHEET 7 OF 8

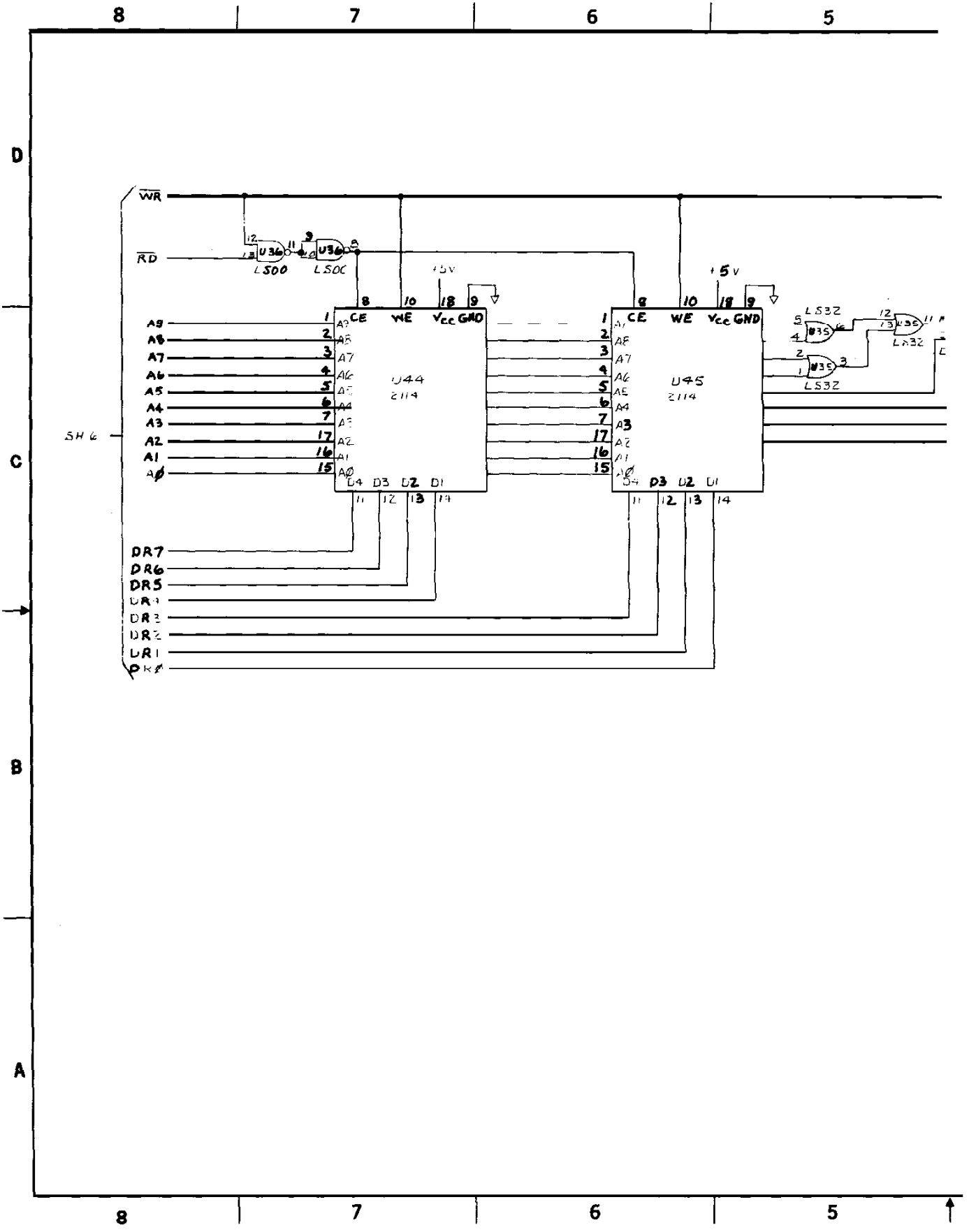

REVISIONS				
ZONE	LTR	DESCRIPTION	DATE	APPROVED
-	-	SEE SHEET 1		

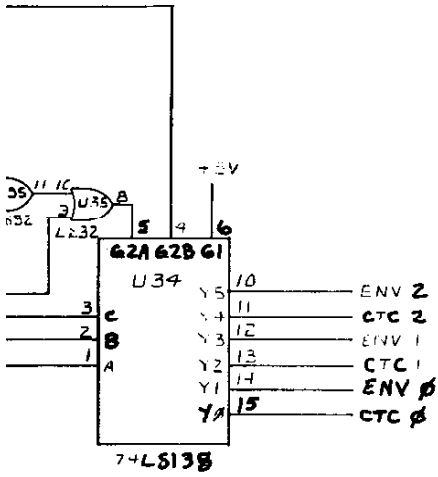

D  
 C  
 B  
 A  
 REV-C-377

QTY REQD	CODE IDENT	PART OR IDENTIFYING NO.	NOMENCLATURE OR DESCRIPTION	ITEM NO.
PARTS LIST				
UNLESS OTHERWISE SPECIFIED DIMENSIONS ARE IN INCHES TOLERANCES ARE:		CONTRACT NO.		
FRACTIONS ±	DECIMALS XX = ±	ANGLES XXX = ±	APPROVALS	DATE
MATERIAL		DRAWN <i>[Signature]</i> 4-14-23		
FINISH		CHECKED <i>[Signature]</i> 6-22-82		
NEXT ASSY		MECH		
USED ON		ELEC		
APPLICATION		MFG		
DO NOT SCALE DRAWING		PROJECT		
		SCALE	SIZE CODE IDENT NO DRAWING NO	REV
			D 800-0377	A
			SHEET 8 OF 8	

**Gremlin/SEGA**  
**UNIVERSAL SOUND BOARD**

A

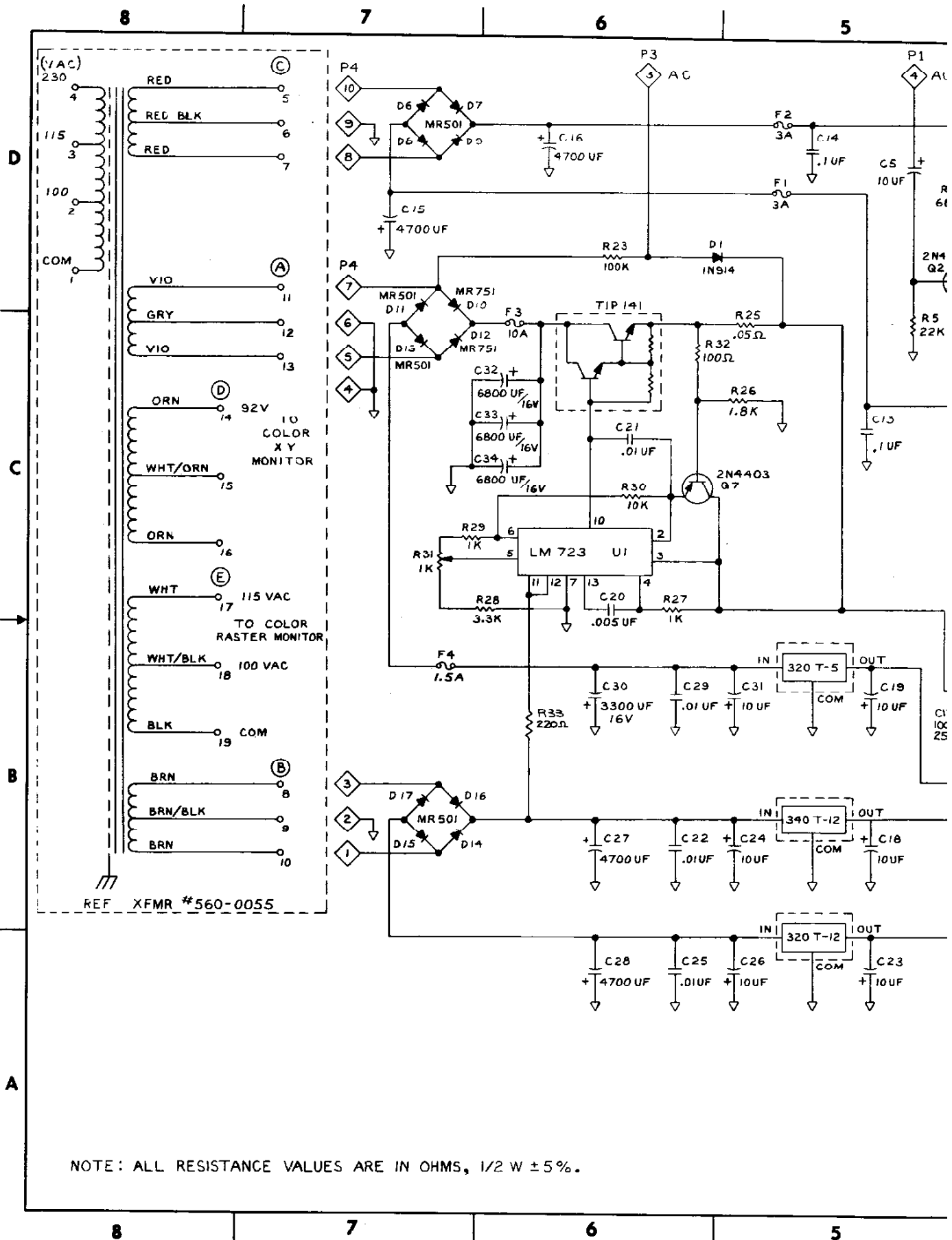

NOTE: ALL RESISTANCE VALUES ARE IN OHMS, 1/2 W ± 5%.



1	2	3	4															
<table border="1"> <tr> <th colspan="4">REVISIONS</th> </tr> <tr> <th>ZONE</th> <th>LTR</th> <th>DESCRIPTION</th> <th>DATE</th> <th>APPROVED</th> </tr> <tr> <td>A</td> <td></td> <td>RELEASED</td> <td>CTC</td> <td>11-16-80</td> <td>J</td> </tr> </table>				REVISIONS				ZONE	LTR	DESCRIPTION	DATE	APPROVED	A		RELEASED	CTC	11-16-80	J
REVISIONS																		
ZONE	LTR	DESCRIPTION	DATE	APPROVED														
A		RELEASED	CTC	11-16-80	J													

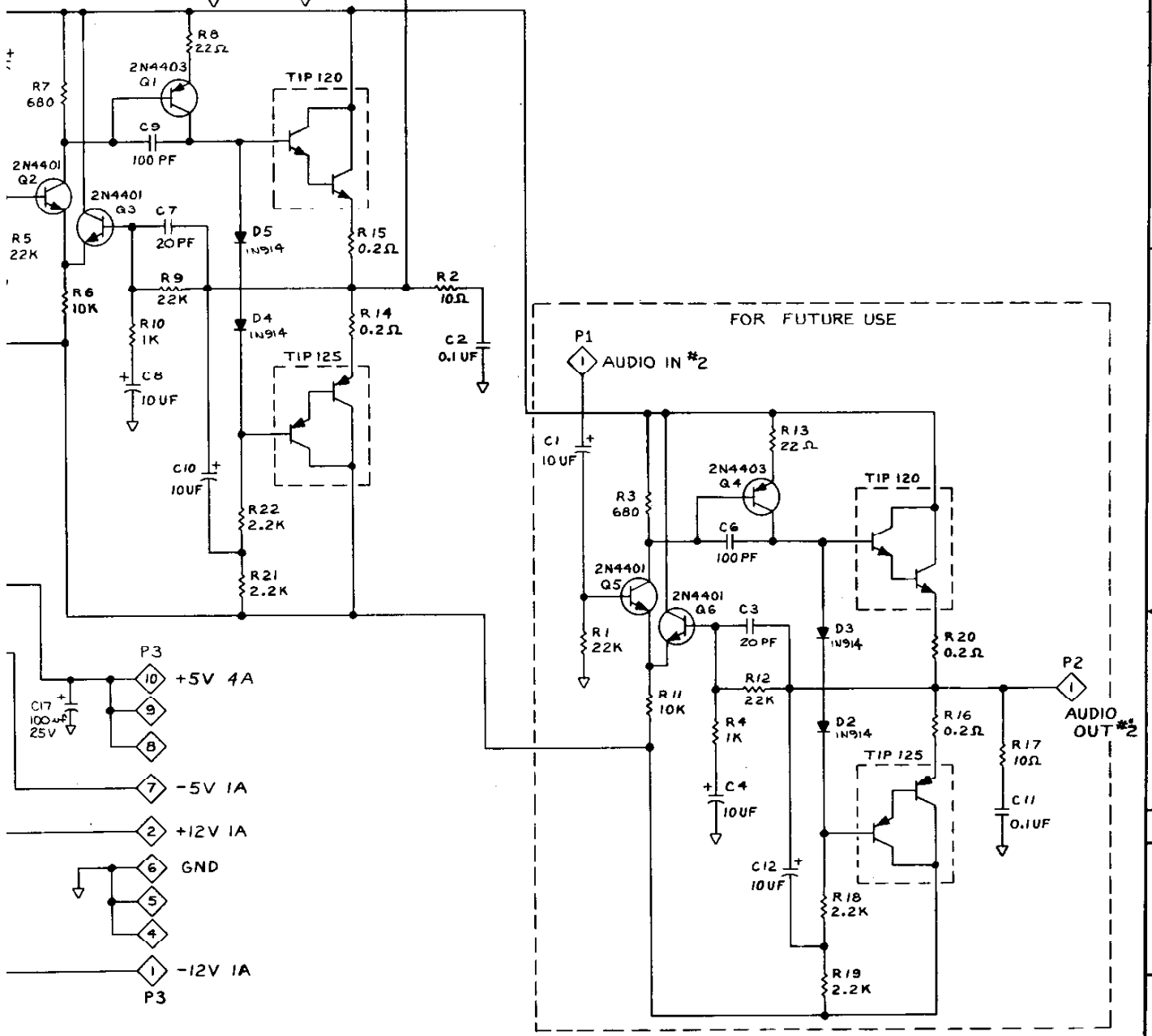

D  
C  
B  
H  
800-0191

QTY REQD	CODE IDENT	PART OR IDENTIFYING NO.	NOMENCLATURE OR DESCRIPTION
PARTS LIST			
UNLESS OTHERWISE SPECIFIED DIMENSIONS ARE IN INCHES TOLERANCES ARE:		CONTRACT NO.	
FRACTIONS	DECIMALS	ANGLES	
±	.XX ±	±	
	.XXX ±		
MATERIAL		APPROVALS	DATE
		DRAWN	12/11/80
		CHECKED	12/16/80
FINISH			
NEXT ASSY USED ON			
APPLICATION		DO NOT SCALE DRAWING	
		<b>Gremlin Industries, Inc.</b> San Diego, California 92123  <b>G-80 POWER SUPPLY</b>	
SIZE	CODE IDENT NO.	DRAWING NO.	REV
D		800-0191	H
SCALE NONE		SHEET 3 OF 3	

NOTES  
UNLESS OTHER  
INDICATED  
FOR RELIABILITY  
WITH

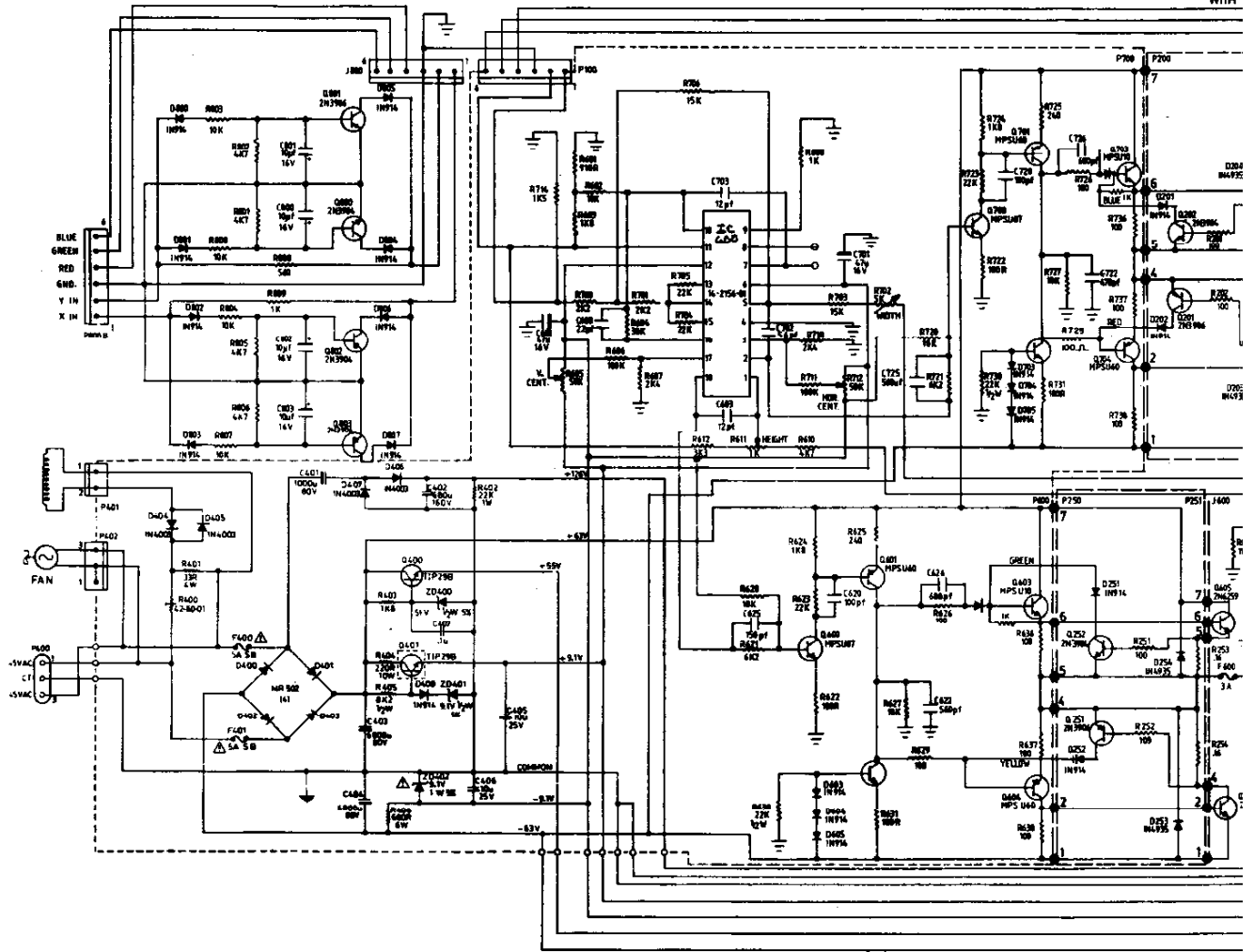

Model Number

RESISTORS OTHERWISE SPECIFIED RESISTANCE (RXX-K, M, or M) ARE 1/4 WATT CARBON RESISTORS. FOR SAFETY PURPOSES (AND CONTINUING RELIABILITY) REPLACE ALL COMPONENTS MARKED WITH SAFETY SYMBOL WITH IDENTICAL TYPE.

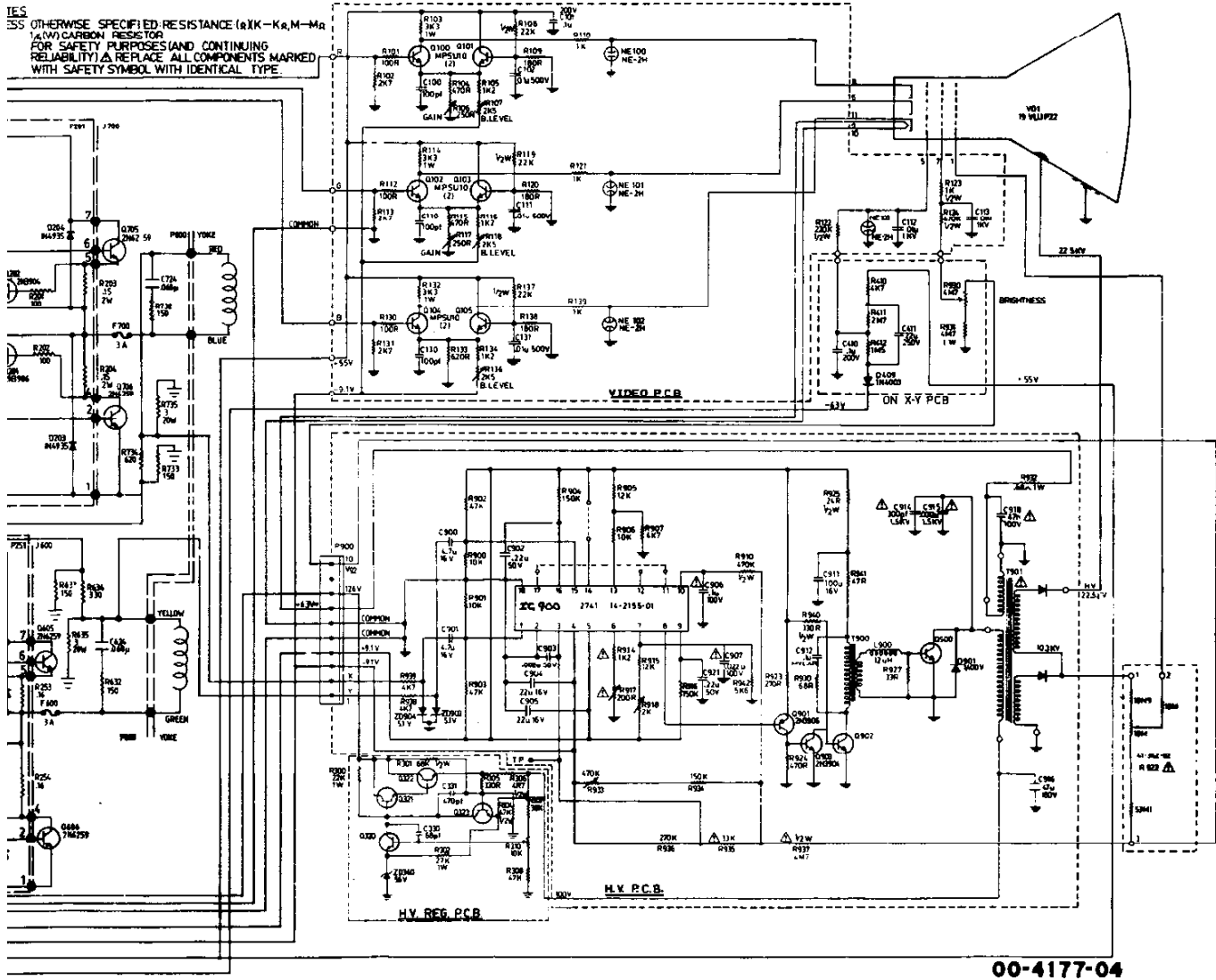

00-4177-04

iber GO8-003

19" X-Y Color Monitor  
200-0025

WE WELCOME YOUR COMMENTS!

Your comments and suggestions will assist us in improving the usefulness of our publications. They are an integral part of preparing for revisions of manuals and parts catalogs.

If you have any technical questions about any SEGA/Gremlin game, are requesting additional publications, or have a suggestion about how we can make our publications more useful to you, drop us a line or use the handy form below. We value your input.

Comments:

Fill in if you wish a reply:

Name \_\_\_\_\_ Firm \_\_\_\_\_  Distributor  
Address \_\_\_\_\_  Operator  
City \_\_\_\_\_ State \_\_\_\_\_ Zip \_\_\_\_\_  Other \_\_\_\_\_

TS

First Fold



NO POSTAGE  
NECESSARY  
IF MAILED  
IN THE  
UNITED STATES

**BUSINESS REPLY MAIL**

FIRST CLASS PERMIT NO. 10129 SAN DIEGO, CALIFORNIA

POSTAGE WILL BE PAID BY ADDRESSEE

**SEGA/GREMLIN**  
**16250 Technology Drive**  
**San Diego, California 92127**

**Attn: Customer Service**

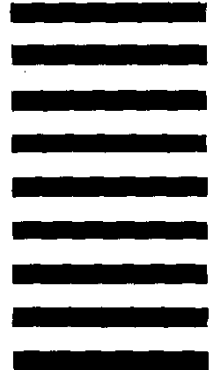

Second Fold

Tape This Edge



# SERVICE NOTE

**EFFECT:** TAC/SCAN

**NUMBER:** 001

There have been some errors identified in the TAC/SCAN™ Owner's Manual (P/N 420-0795). Please correct your documentation as follows:

- At the top right-hand corner of pages 40 through 44, correct the Drawing Number to read 700-0106-01.
- At the top right-hand corner of pages 45 through 50, correct the Drawing Number to read 700-0106-00.
- On pages 40 and 46, please add this information to ITEM NO. 30 on both sheets:

<u>ITEM NO.</u>	<u>PART NO.</u>	<u>QTY REQ'D.</u>	<u>DESCRIPTION</u>
30.	253-0245-00	1	CRT Mask

- The two attached sheets contain part numbers for programmed IC's used on TAC/SCAN™ CPU and 2716 EPROM Boards. Please include them with your Owner's Manual.

SEGA Electronics, Inc. 16250 Technology Drive, San Diego, CA. 92127-1985

Toll-free technical assistance 1-800-854-1938 outside CA.

1-800-722-8576 inside CA.

<u>ITEM NO.</u>	<u>PART NO.</u>	<u>QTY. REQ'D</u>	<u>DESCRIPTION</u>	<u>REF. DESG.</u>
1	316-1670-00	1	IC EPROM 2716	U1
	316-1671-00	1	IC EPROM 2716	U2
	316-1672-00	1	IC EPROM 2716	U3
	316-1673-00	1	IC EPROM 2716	U4
	316-1674-00	1	IC EPROM 2716	U5
	316-1675-00	1	IC EPROM 2716	U6
	316-1676-00	1	IC EPROM 2716	U7
	316-1677-00	1	IC EPROM 2716	U8
	316-1678-00	1	IC EPROM 2716	U9
	316-1679-00	1	IC EPROM 2716	U10
	316-1680-00	1	IC EPROM 2716	U11
	316-1681-00	1	IC EPROM 2716	U12
	316-1682-00	1	IC EPROM 2716	U13
	316-1683-00	1	IC EPROM 2716	U14
	316-1684-00	1	IC EPROM 2716	U15
	316-1685-00	1	IC EPROM 2716	U16
	316-1686-00	1	IC EPROM 2716	U17
	316-1687-00	1	IC EPROM 2716	U18
	316-1688-00	1	IC EPROM 2716	U19
	316-1709-00	1	IC EPROM 2716	U20
	316-1710-00	1	IC EPROM 2716	U21
2	800-0151-00	1	ASSY G-80 2716 PROM BOARD	

ASSY. CPU PCB

DRAWING NUMBER 800-3268

<u>ITEM NO.</u>	<u>PART NO.</u>	<u>QTY. REQ'D</u>	<u>DESCRIPTION</u>	<u>REF. DESG.</u>
1	316-1711-00	1	IC EPROM 2716	U25
2	315-0076-00	1	CHIP 315-0082	U21
3	800-0107-00	1	ASSY. CPU BOARD	





**EFFECT:** TAC/SCAN™ CONVERT-A-PAK

**NUMBER:** 002 11/24/82

It has been noted that a number of TAC/SCAN™ CONVERT-A-PAK's (P/N 700-0107) have left the factory with two possible assembly problems. We recommend that you perform the following simple checks:

1. With the front electronics compartment door open, reach up on both sides and flip the control panel latches up. Swing the control panel up and out, revealing the control panel harness connector on your right. With each wire, one at a time, tug firmly (though NOT HARD), checking for loose pin crimps. In the event that any wires do pull out of the connector, an attempt can be made to salvage the pins; using a Molex pin extractor, remove the pin from the connector. Pry open the crimp, re-insert the wire, and re-crimp the pin onto the wire. If the pin cannot be saved, replacement Molex female pins (P/N 211-0042) are available from your distributor.
2. Facing an open G-80 card cage, note the red plastic connectors at the front edge of the various cards. This is an "insulation-displacement" type of connector, and the problem here is that the wires may not be inserted into the connector far enough to effect an electrical connection. Simply take any thin-bladed screwdriver (a "tweezer" is ideal) and push the wires further into the connector. This forces the wire between two metal "blades", cutting the insulation and bringing the conductor into physical contact with that particular "pin-out".

SEGA Electronics, Inc., 16250 Technology Drive, San Diego, CA. 92127-1985

Toll-free technical assistance: 1-800-854-1938 outside CA.

1-800-722-8576 inside CA.

