



©CAPCOM CO., LTD. 1996 ALL RIGHTS RESERVED

OPERATORS MANUAL



WARNING

This game is for use in the United States of America and Canada. Sales, export or operation outside of these countries may be constructed as copyright and trademark infringements and is strictly prohibited. Violators are subject to severe penalties and will be prosecuted to the full extent of the law.

CAPCOM[®] COIN-OP, INC.

3311 N. Kennicott Avenue
Arlington Heights, Illinois 60004

Phone: (847) 797-6100

Fax: (847) 797-6306

PM00157-KIT
031996

THANK YOU FOR PURCHASING A **STREET FIGHTER ALPHA 2™** VIDEO KIT. WE INVITE YOU TO USE THE FOLLOWING MAILING ADDRESS, TELEPHONE OR FAX NUMBER FOR PARTS OR SERVICE INFORMATION CONCERNING THIS GAME:

CAPCOM® COIN-OP, INC.
ATTN: FIELD SERVICE - VIDEO PRODUCTS
3311 N. KENNICOTT AVENUE
ARLINGTON HEIGHTS, ILLINOIS 60004
PHONE: (847) 797-6100
FAX: (847) 797-6306

THE SERIAL NUMBERS OF YOUR KIT ARE LOCATED ON THE GAME CARTRIDGES AS SHOWN BELOW. PLEASE HAVE THESE SERIAL NUMBERS AVAILABLE WHEN CONTACTING US FOR SERVICE INFORMATION.

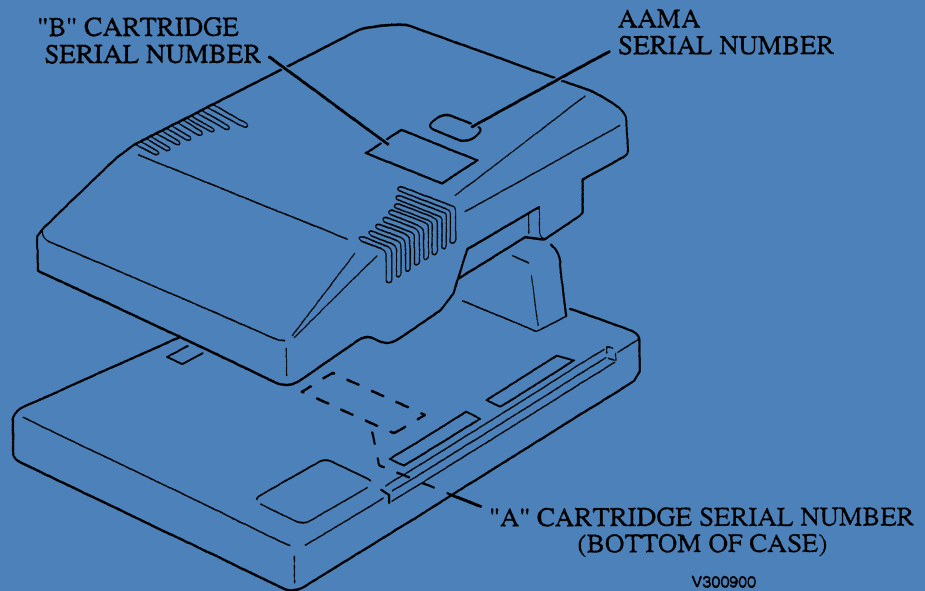

DEPENDING ON THE TYPE OF KIT YOU PURCHASED, PLEASE RECORD THE SERIAL NUMBERS HERE:

"FULL" KIT	A-CARTRIDGE SERIAL #	_____
	B-CARTRIDGE SERIAL #	_____
	AAMA SERIAL #	_____
"B" KIT	B-CARTRIDGE SERIAL #	_____
	AAMA SERIAL #	_____

TABLE OF CONTENTS

<i>Warranty Information</i>	ii
<i>Kit Inspection</i>	1
<i>Kit Installation</i>		
“FULL” Kit		
Preparation	3
Installation	3
Marquee	3
System Wiring	5
Test Bracket	6
Game Cartridge(s)	6
“B” Kit		
Preparation and Installation	7
<i>Test Mode</i>		
Test Menu	9
Accessing the Menu	9
How to Select an Item	9
Closing the Menu	10
Menu Item Descriptions	10
Configuration Menu	11
System Configuration	12
Game Configuration	13
<i>Cable Wiring</i>		
JAMMA Connections	14
Auxiliary Cable Connections	14
<i>Template : Control Panel Drill Hole(s)</i>		

LIMITED PRODUCT WARRANTY (APPLIES TO DOMESTIC SALES ONLY)

CAPCOM® COIN-OP, INC. (Seller), warrants only to the initial purchaser of its products, that the items listed below are free from defects in material and workmanship under normal use and service for the warranty periods specified:

- | | |
|--|--------------|
| A. CPS II System Cartridges | One (1) Year |
| B. Electronic and Mechanical Components: | (90) days |

No other part of Seller's products are warranted.

Warranty periods are effective from the initial date of shipment from seller to its authorized distributors.

Seller's sole liability shall be, at its option, to repair or replace products which are returned to Seller during the warranty periods specified, provided:

- A. Seller is notified promptly upon discovery by buyer that stated products are defective;
- B. Such products are properly packaged and then returned, prepaid to Seller's designated plant.

This warranty does not apply to any parts damaged during shipment or handling, or due to improper installation or usage, or alteration. In no event shall Seller be liable for any anticipated profits, loss of profits, loss of use, incidental or consequential damages or any other losses incurred by the customer in connection with the purchase of a CAPCOM® COIN-OP, INC. product.

WARRANTY DISCLAIMER

EXCEPT AS SPECIFICALLY PROVIDED IN A WRITTEN CONTRACT BETWEEN SELLER AND PURCHASER, THERE ARE NO OTHER WARRANTIES, EXPRESSED OR IMPLIED, INCLUDING ANY IMPLIED WARRANTIES OF MERCHANTABILITY OR FITNESS FOR A PARTICULAR PURPOSE.

IMPORTANT NOTICE

THIS SHIPMENT HAS BEEN CAREFULLY INSPECTED AND PROPERLY PACKAGED BEFORE LEAVING THE FACTORY. WE CANNOT ASSUME RESPONSIBILITY FOR BREAKAGE THAT MAY OCCUR DURING TRANSPORTATION OF THE GAME. IF THIS GAME IS DAMAGED UPON RECEIPT FROM THE CARRIER, IMMEDIATELY NOTIFY THE CARRIER AND FILE A DAMAGE REPORT.

KIT INSPECTION

There are two kits available for conversion to **STREET FIGHTER™ : ALPHA 2**

- 1) **SFAT1000** ("FULL" kit) contains the complete game cartridges, all necessary graphics, and replacement joysticks and button switches. The "FULL" kit is intended for conversion of most JAMMA-compatible, horizontal screen cabinets.
- 2) **SFAT1000B** ("B" kit) contains the game software cartridge (B-cartridge) and must also be installed to a current CAPCOM® System II game. It includes all the necessary game graphics for a cabinet conversion (marquee, control panel overlay, monitor card, etc.).

Check that all parts have been shipped with your kit. If any parts are missing, contact your distributor immediately.

KIT PARTS LIST

SFA1000	SFA1000B	PART NO.	DESCRIPTION	QTY
√		A-00653	CPS II System Cartridges (A/B)	1
	√	A-00654	CPS II System Cartridge (B)	1
√	√	GE1200	Monitor Card	1
√	√	AW00209	Marquee	1
√	√	AW00145-1	Overlay, Control Panel	1
√	√	AW00211	Decal, Joystick & Button Switches	1
√	√	AW00212	Decal, Cabinet Side	2
√	√	AW00210-01	Decal - Top, Instruction	1
√	√	AW00210-02	Decal - Btm., Instruction	1
√	√	PM00157-KIT	Manual, Operators	1
√		03-0052	Cable, Auxiliary	1
√		GE2030	Joystick	2
√		16-0130	Switch, 1-Player Start Button (White)	1
√		16-0131	Switch, 2-Player Start Button (White)	1
√		16-0133	Switch, Button (Red)	4
√		16-0134	Switch, Button (Blue)	4
√		16-0136	Switch, Button (Green)	4
√		03-0050	Bracket, Volume/Test	1
√		13-0066	Bracket, A-Cartridge Mounting	4
√		SC00104-05	Screw, Wood	4

CAUTION

Please read the following instructions to keep the PC board in good condition:

- ◆ Do not block the ventilation slots.
- ◆ Do not drop or bump the board.
- ◆ Do not spill any liquids on the case.
- ◆ Do not disassemble the case.

ATTENTION

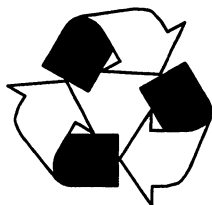

The product that you have purchased contains a recyclable battery. At the end of its useful life, under various state and local laws, it may be illegal to dispose of this battery into the municipal waste system. Check with your local solid waste official for details in your area for recycling options or proper disposal.

DISASSEMBLING THE CASE OR REMOVING THE STICKER MAY CAUSE THE TERMINATION OF YOUR REPAIR WARRANTY.

“FULL” KIT INSTALLATION



WARNING:

MAKE SURE ELECTRICAL POWER TO THE GAME IS OFF BEFORE STARTING THE KIT INSTALLATION.

PREPARATION

1. Disconnect and remove the old printed circuit board(s) from the cabinet.
2. Remove or open the control panel, and disconnect and remove the buttons and joystick(s) from the control panel.
3. Remove any covering from the control panel overlay, and then remove the control panel overlay.
4. Place the Drill Hole Template (included in this manual) over the control panel to determine where any new holes should go. Center punch any needed new holes on the control panel.
5. Cut out the new holes using a 1-3/16" hole saw.
6. If there is an additional control panel cover (such as plastic or lexan) that will be utilized, cut any additional holes using the same template.
7. Plug up unused holes with wood dowel (1-1/8" diameter), being careful to sand any rough edges, or use available button plugs.

INSTALLATION

Marquee Installation

8. Remove the marquee glass, old marquee overlay, and the old cabinet graphics.
9. Install the new marquee and replace the glass.

Control Panel Overlay Installation (See Figure 1)

10. The control panel overlay in the kit is oversized to accommodate most control panel sizes. Center the

overlay on the control panel, leaving some excess material at the edges.

11. Remove the protective backing from the overlay and press it down on the control panel, keeping it properly aligned. Press it down firmly, smooth out any bubbles, and press it over the edges.

12. Trim any excess from the overlay. Place the drill hole template on top of the overlay, aligning it with the joystick holes. Pierce through the overlay at each control panel hole. Then, cut away overlay material covering the joystick and button holes. Remove the template and clean off the overlay.

13. Peel off the backings of the 6-button and joystick decals, align over the control panel holes, and press in place on the overlay (refer to the drill hole template for proper placement). Using a knife, trim material from the center hole of the joystick decal.

14. Install the control panel cover (if required).

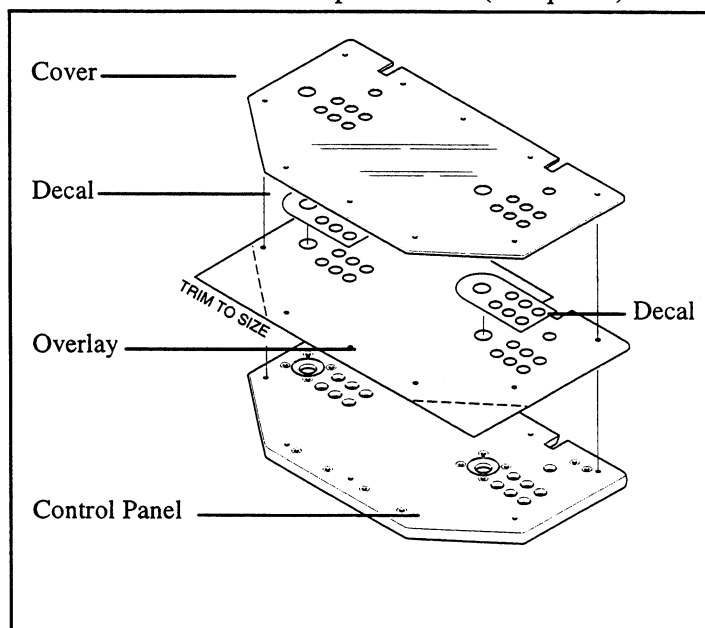

Figure 1
Overlay Installation

Reassembly of Components

15. Install all buttons and retaining rings on the control panel as shown in Figure 2. Install two RED buttons to the immediate right of each joystick, install two GREEN buttons to the right of the red ones, and install two BLUE buttons to the right of the green ones.

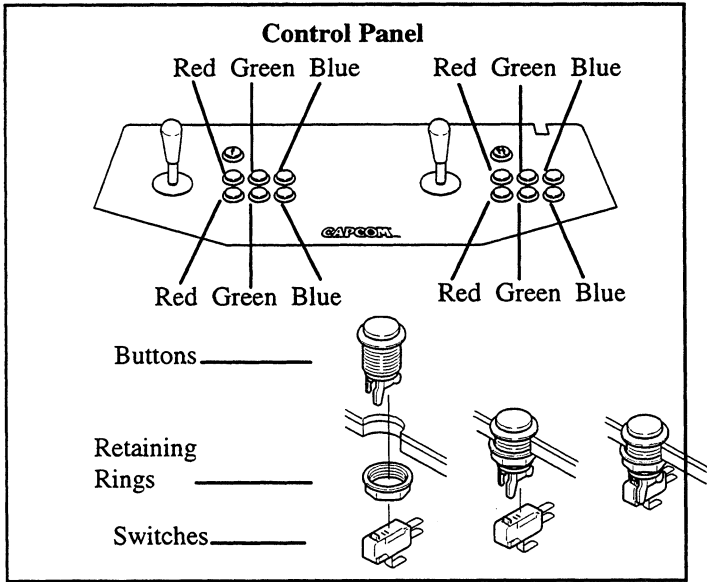

FIGURE 2
Control Panel Buttons and Switches

16. Notice that there are two white buttons. (See Figure 3.) Install the PLAYER ONE button on the top left-hand side of the control panel, and the PLAYER TWO button on the top right-side of the control panel. The WHITE buttons are START buttons.

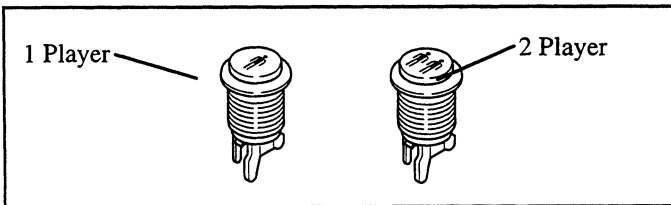

FIGURE 3
Function and Start Buttons

17. Install the switches on the buttons as shown in Figure 2. Orient the switches so that when a button is pressed, the red contact on the switch is depressed.

18. Install the joysticks on the control panel as shown in Figure 4.

Wiring

NOTE:

All switch wires used in this game must be wired to the normally-open connection on the switches. Each switch requires a ground wire on the common

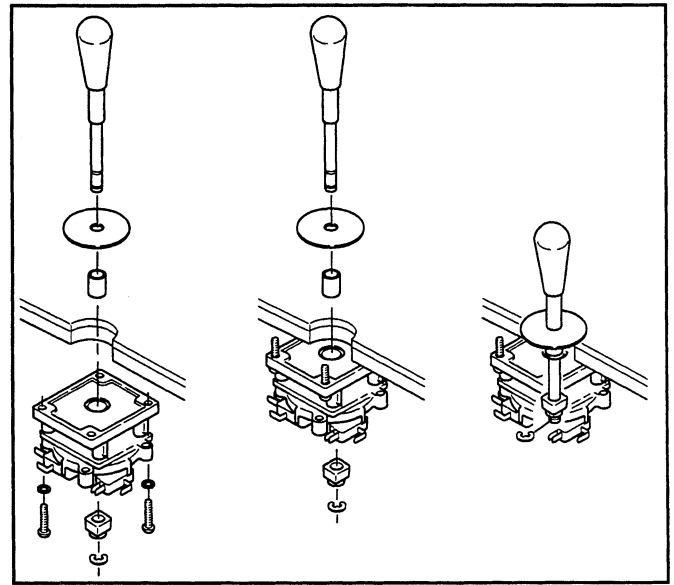

FIGURE 4
Joystick Installation

connector and the appropriate control or switch wire on the normally-open connector of the switch.

19. Reconnect the existing JAMMA connectors to the control panel according to the chart of Figure 5.

20. Connect the Player 1 and Player 2 Kick buttons to the auxiliary cable harness connectors shown in Figure 6. Make the connections according to the chart of Figure 7.

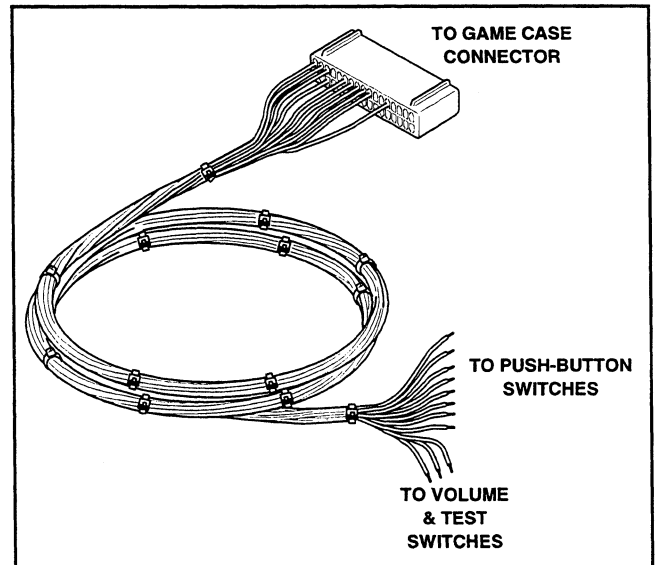

FIGURE 6
Auxiliary Cable Harness

JAMMA CONNECTOR REF.	*WIRE COLOR	CONNECTS TO	COMPONENT	FUNCTION
18	WHITE/BLACK	PLAYER 1	JOYSTICK	UP
19	WHITE/BROWN	PLAYER 1	JOYSTICK	DOWN
20	WHITE/RED	PLAYER 1	JOYSTICK	LEFT
21	WHITE/ORANGE	PLAYER 1	JOYSTICK	RIGHT
22	WHITE/YELLOW	PLAYER 1	PUNCH BUTTON	JAB
23	WHITE/GREEN	PLAYER 1	PUNCH BUTTON	STRONG
24	WHITE/BLUE	PLAYER 1	PUNCH BUTTON	FIERCE
V	VIOLET/BLACK	PLAYER 2	JOYSTICK	UP
W	VIOLET/BROWN	PLAYER 2	JOYSTICK	DOWN
X	VIOLET/RED	PLAYER 2	JOYSTICK	LEFT
Y	VIOLET/ORANGE	PLAYER 2	JOYSTICK	RIGHT
Z	VIOLET/YELLOW	PLAYER 2	PUNCH BUTTON	JAB
a	VIOLET/GREEN	PLAYER 2	PUNCH BUTTON	STRONG
b	VIOLET/BLUE	PLAYER 2	PUNCH BUTTON	FIERCE

Figure 5: Control Panel JAMMA Wiring Connections

* **Wire Color Note:** Wire colors shown are according to the AAMA -AMOA Standard for wire color assignments; your harness may contain different colors than shown above.

AUXILIARY CABLE CONNECTOR REF.	WIRE COLOR	CONNECTS TO	COMPONENT	FUNCTION
34	BLACK	PLAYER 1	KICK BUTTON	COMMON
19	BLUE	PLAYER 1	KICK BUTTON	SHORT
17	RED	PLAYER 1	KICK BUTTON	FORWARD
15	PINK	PLAYER 1	KICK BUTTON	ROUNDHOUSE
33	BLACK	PLAYER 2	KICK BUTTON	COMMON
21	GRAY/YELLOW	PLAYER 2	KICK BUTTON	SHORT
23	PINK/YELLOW	PLAYER 2	KICK BUTTON	FORWARD
9	PURPLE/YELLOW	PLAYER 2	KICK BUTTON	ROUNDHOUSE
29	GRAY/YELLOW	TEST BRACKET	VOLUME SWITCH	UP
30	PINK/YELLOW	TEST BRACKET	VOLUME SWITCH	DOWN
31	BLACK/WHITE	TEST BRACKET	VOLUME SWITCH	COMMON

Figure 7: Auxiliary Cable Wiring Connections for Control Panel and Test Bracket

21. An optional Test/Volume bracket (see Figure 8) is included in this kit. Your cabinet may already contain this bracket. If you decide to install, the bracket should be mounted inside the coin door and on top of the cash box for easy access.

NOTE: The A-cartridge also contains the same Test and Volume functions found on the test bracket.

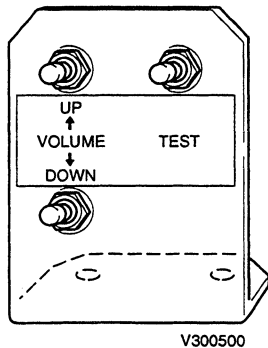

Figure 8: Test Bracket

Wiring of the Test Bracket requires connections to both the main JAMMA harness as well as the auxiliary cable harness (refer to Figure 9).

LEAD WIRE COLOR	SWITCH FUNCTION	CONNECTS TO
YELLOW	VOLUME-UP	AUX. CABLE '29' (GRAY/YELLOW)
GREEN	COMMON	AUX. CABLE '31' (BLACK/WHITE)
BLACK	VOLUME-DOWN	AUX. CABLE '30' (PINK/YELLOW)
GREEN	COMMON	AUX. CABLE '31' (BLACK/WHITE)
BROWN	TEST	JAMMA '15'
BLACK	GROUND	JAMMA 'A' or 'B' or 'e' or 'f' or '1' or '2' or '27' or '28'

Figure 9: Test Bracket Wiring Chart

GAME CARTRIDGE INSTALLATION

22. Install the four (4) mounting brackets to the underside of the "A" cartridge as shown in Figure 10.

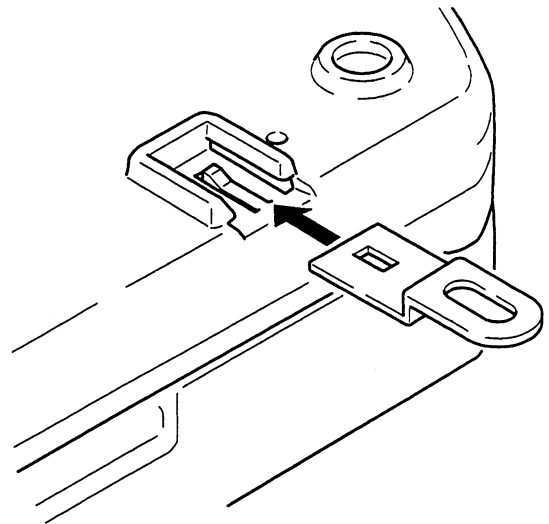

Figure 10: Mounting Bracket Installation

23. Using the supplied wood screws, fasten the game cartridge case to the control panel shelf, as shown in Figure 11.

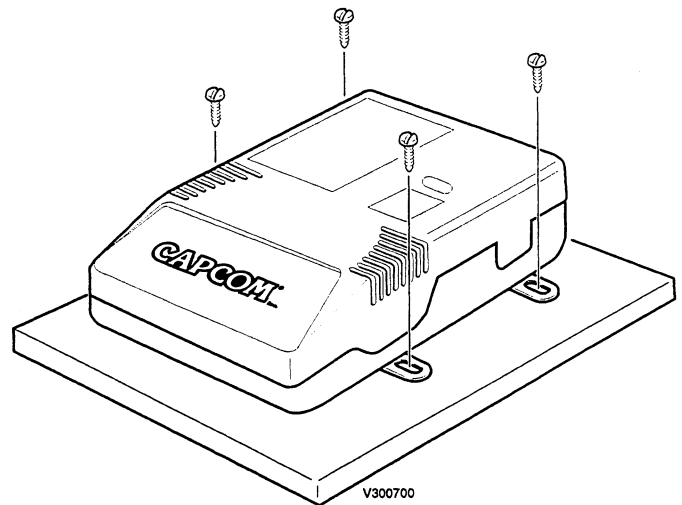

Figure 11: Case Mounting

24. Connect the JAMMA harness connector and the auxiliary cable connector to the "A" cartridge. If your cabinet is equipped with Q-SOUND, also attach the audio cables.

**WARNING**

Improper installation of the JAMMA harness connector to the game cartridge will cause damage to the enclosed PCB.

25. Power-up the game and set all operator adjustable options by pressing the **TEST** switch. Follow the instructions under the **TEST MENU** section of this manual.

“B” KIT INSTALLATION

1. To install the cabinet graphics, you must follow the “FULL” Kit Preparation and Installation Procedure, steps 3 through 14.
2. To remove the existing “B” cartridge from the “A” cartridge, pull the old case clamps apart (see Figure 12). Carefully remove the old “B” cartridge and install the new “B” cartridge. Re-install the case clamps.

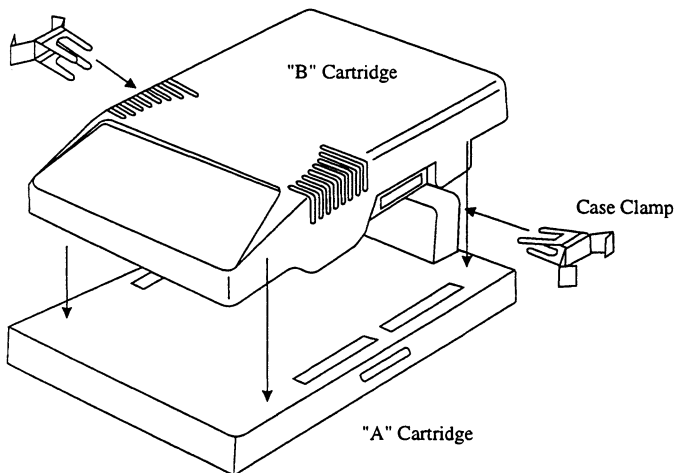

Figure 12 : Case Clamp Installation

**WARNING**

DISASSEMBLY OF EITHER GAME CARTRIDGE WILL VOID YOUR WARRANTY.

3. Power-up the game and set all operator adjustable options by pressing the **TEST** switch. Follow the instructions under the **TEST MENU** section of this manual.

NOTES

TEST MENU

The test menu allows you to test the functions and configure the game. These items include input devices such as joysticks, buttons and coin door or switches, output devices such as monitor, speakers and meters. Through the Test Menu you can also access the Configuration Menu, where you can change the settings of the game.

1. ACCESSING THE TEST MENU

- **For a CAPCOM® cabinet, or a cabinet with a test switch:**
Make sure the game is on and push the test switch. The screen shown below will appear.
- **For a cabinet without a test switch:**
Push the blue test switch on the outside of the black plastic casing (refer to the inside back cover of the manual).

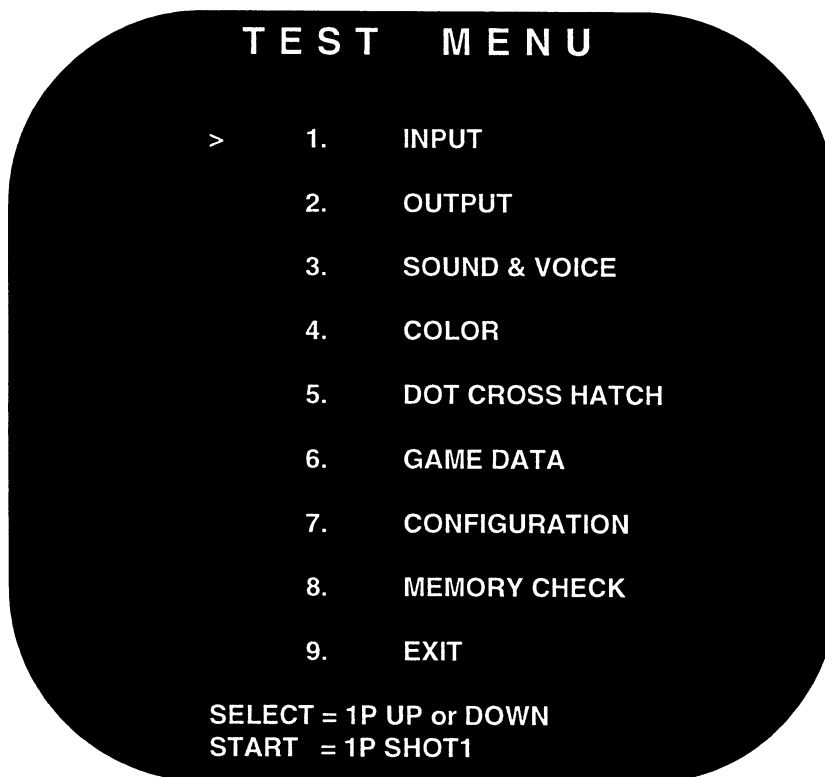

2. HOW TO SELECT AN ITEM

- Use the *PLAYER 1 JOYSTICK* to move the arrow in front of the desired item and press the *PLAYER 1 SHOT 1 (PUNCH-JAB)* button.
- To return to the test menu, push the *PLAYER 1 START* and *PLAYER 1 SHOT 1(PUNCH-JAB)* buttons simultaneously.
- The test menu will always return to the screen:
 - a) After you exit the “**7. CONFIGURATION MENU**” and
 - b) After the memory is tested from the menu, “**8. MEMORY CHECK**”.

3. CLOSING THE TEST MENU

To close the Test Menu, highlight “9. EXIT” and push the *PLAYER 1 SHOT 1(PUNCH-JAB)* button.

4. TEST MENU ITEM DESCRIPTIONS

INPUT	Used to test all the input switches, such as joysticks and buttons. The “0” changes to a “1” as the button is pushed or joystick is moved. Check connections and switches in case the “0” doesn’t change to a “1” when depressed or moved.
OUTPUT	Used to test the coin meter and the coin lock.
SOUND & VOICE	Select a code of SOUND or VOICE with the <i>PLAYER 1 JOYSTICK</i> . Push the <i>PLAYER 1 SHOT 1 (PUNCH-JAB)</i> button to hear the sound of the selected code.
COLOR	Shows color bars of red, green, blue, and white. Adjust RGB and brightness to obtain the optimum color balance and solid black background.
DOT CROSS HATCH	Used to test the screen size, focus and distortion.
GAME DATA	Coin meter and playtime information will be displayed.
CONFIGURATION	Used to change the game play settings. Refer to the CONFIGURATION MENU section.
MEMORY CHECK	Used to test memory. “OK” appears when each block of memory passes test, “NG” appears in case of malfunction. If “NG” appears, repeat the memory test and wait for the “OK” message. Contact your distributor if “NG” still appears.
EXIT	Select this item and push the <i>PLAYER 1 SHOT 1(PUNCH-JAB)</i> button to return to game play mode.

CONFIGURATION MENU

The Configuration Menu is used to change various game settings such as level difficulty, credits, sound configuration, etc. These settings are stored in memory on the PCB.

The Configuration Menu is divided into 2 sections. In the **SYSTEM** section, you can change credits, sound, and coin door configurations. In the **GAME** section, you can change the play difficulty level and duration of the game.

1. ACCESSING THE CONFIGURATION MENU

- From the TEST MENU, move the arrow to “7. CONFIGURATION” and push the *PLAYER 1 SHOT 1 (PUNCH-JAB)* button. The screen below will be displayed. A description of each option is explained in the table below.

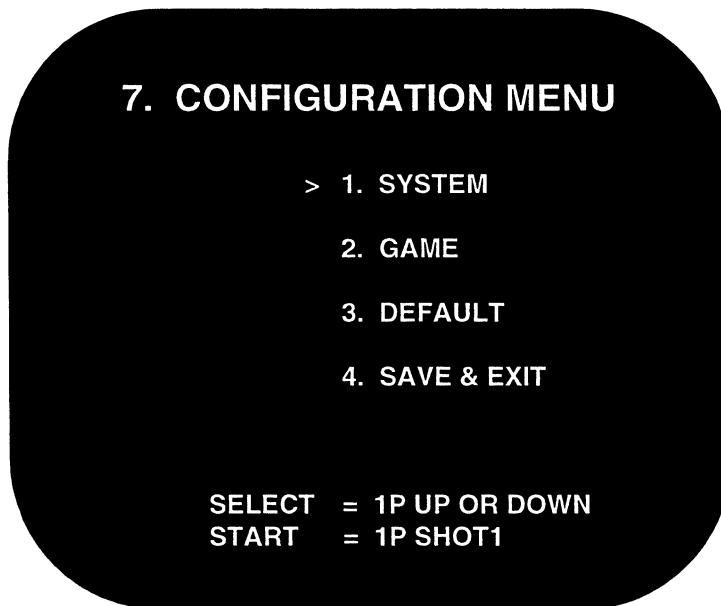

SYSTEM	Select this item to change settings for credits, monitor flip, sound and coin door configurations.
GAME	Select this item to change difficulty level, damage level, time count speed, maximum number of rounds and event type.
DEFAULT	Use this item to restore configuration settings to the original factory values. Press the <i>PLAYER 1 SHOT 1 (PUNCH-JAB)</i> and <i>PLAYER 1 SHOT 2 (PUNCH-STRONG)</i> buttons at the same time to restore default values.
SAVE & EXIT	Use this to save new configuration settings and exit to the Test Menu. The message “SAVING NEW CONFIGURATION IN EEPROM” will appear while the new settings are being saved. DO NOT turn power off to the game until “SAVING” is complete and the Test Menu reappears.

SYSTEM CONFIGURATION

CHANGING THE SYSTEM CONFIGURATION SETTINGS

Move the *PLAYER 1 JOYSTICK* up or down to highlight the desired option. Once the option is highlighted, move the *PLAYER 1 JOYSTICK* left or right or press the *PLAYER 1 SHOT 1(PUNCH-JAB)* button to select.

7-1. SYSTEM CONFIGURATION

> 1. COIN MODE	2 COINS 1 CREDIT
2. CONTINUE	ON
3. MONITOR	NORMAL
4. DEMO SOUND	ON
5. SOUND MODE	STEREO (QSOUND)
6. CHUTE TYPE	2 CHUTES SINGLE
7. EXIT	

SELECT OPTION = 1P UP OR DOWN
 MODIFY SETTING = 1P LEFT OR RIGHT
 = 1P SHOT1 OR SHOT2

SYSTEM CONFIGURATION ITEM DESCRIPTIONS

1. COIN MODE	SELECT THE CHARGE PER PLAY.
2. CONTINUE	SELECT ON FOR CONTINUOUS PLAY OR OFF FOR NON-CONTINUOUS PLAY.
3. MONITOR	FLIPS THE POSITION OF THE SCREEN. IF THE SCREEN APPEARS UPSIDE-DOWN, CHANGE THE SETTING TO FLIP; IF THE SCREEN APPEARS CORRECT, SELECT NORMAL.
4. DEMO SOUND	TURNS ATTRACT SOUNDS ON OR OFF.
5. SOUND MODE	SELECT STEREO OR MONAURAL FOR USE WITH YOUR CABINET. NOTE: STEREO SHOULD ONLY BE SELECTED FOR USE WITH CAPCOM® QSOUND CABINETS.
6. CHUTE TYPE	SELECT THE NUMBER OF PLAYER(S) AND COIN CHUTE TYPE.
7. EXIT	TO SAVE THE SETTINGS AND RETURN TO THE CONFIGURATION MENU, HIGHLIGHT THIS ITEM AND PUSH EITHER THE <i>PLAYER 1 SHOT 1 (PUNCH-JAB)</i> BUTTON OR THE <i>PLAYER 1 SHOT 2 (PUNCH-STRONG)</i> BUTTON.

SYSTEM CONFIGURATION OPTION SETTINGS

1. COIN MODE	1 COIN 1 CREDIT	1 COIN 2 CREDITS	1 COIN 3 CREDITS	1 COIN 4 CREDITS	1 COIN 5 CREDITS	
	1 COIN 6 CREDITS	1 COIN 7 CREDITS	1 COIN 8 CREDITS	1 COIN 9 CREDITS	2 COINS 1 CREDIT	
	3 COINS 1 CREDIT	4 COINS 1 CREDIT	5 COINS 1 CREDIT	6 COINS 1 CREDIT	7 COINS 1 CREDIT	
	8 COINS 1 CREDIT		9 COINS 1 CREDIT		2 COINS START 1 COIN CONTINUE	FREE PLAY
	ON			OFF		
2. CONTINUE	NORMAL			FLIP		
3. MONITOR	ON			OFF		
4. DEMO SOUND	STEREO (Q SOUND)			MONAURAL		
5. SOUND MODE	2 CHUTES SINGLE		2 CHUTES MULTI		1 CHUTE SINGLE	
6. CHUTE TYPE						

NOTE: FACTORY SETTING

GAME CONFIGURATION

CHANGING THE GAME CONFIGURATION SETTINGS

Move the *PLAYER 1 JOYSTICK* up or down to highlight the desired option. Once the option is highlighted, move the *PLAYER 1 JOYSTICK* left or right or press the *PLAYER 1 SHOT 1 (PUNCH-JAB)* button to select.

7-2. GAME CONFIGURATION

>	1. DIFFICULTY	HARD 2
	2. DAMAGE LEVEL	MEDIUM
	3. TIMER SPEED	SLOW
	4. GAME SPEED	TURBO 2
	5. MAX ROUND	3 ROUNDS
	6. EVENT	OFF
	7. AUTOMATIC	OFF
	8. EXIT	

SELECT OPTION = 1P UP OR DOWN

MODIFY SETTINGS = 1P LEFT OR RIGHT
1P SHOT1 OR SHOT2

GAME CONFIGURATION ITEM DESCRIPTIONS

1. *DIFFICULTY	SETS THE GAME DIFFICULTY LEVEL.
2. *DAMAGE LEVEL	SETS THE ATTACK DAMAGE LEVEL.
3. TIMER SPEED	SETS THE SPEED OF THE COUNTDOWN FOR THE TIMER DISPLAY.
4. *GAME SPEED	SETS THE SPEED AT WHICH THE CHARACTERS FIGHT.
5. MAX ROUND	SETS THE NUMBER OF ROUNDS PER MATCH 1 ROUND: WINNER OF THE SINGLE ROUND WINS. 3 ROUNDS: WINNER OF 2 OUT OF 3 ROUNDS WINS. 5 ROUNDS: WINNER OF 3 OUT OF 5 ROUNDS WINS.
6. EVENT	OFF- NORMAL SETTING 1 MATCH- MATCHES PLAYER WITH ONE CREDIT. A WIN OR A LOSS RESULTS IN GAME OVER (<i>CONTINUE</i> IS NOT AVAILABLE).
7. AUTOMATIC	SETS AN AUTOMATIC BLOCKING FEATURE FOR MOST CHARACTERS (USED FOR BEGINNING PLAYERS). NOT RECOMMENDED FOR MOST LOCATIONS.
8. EXIT	RETURN TO THE CONFIGURATION MENU.

***NOTE:** IN THE EVENT THAT THESE SETTINGS REQUIRE ADJUSTMENT, PLEASE CONTACT US FOR ADDITIONAL INFORMATION AND RECOMMENDATIONS FOR MAXIMUM GAME EARNINGS.

GAME CONFIGURATION OPTIONS

1. DIFFICULTY	EASY	NORMAL	HARD 1	HARD 2	HARD 3
	HARD 4		HARD 5		EXPERT
2. DAMAGE LEVEL	LOW	MEDIUM	NORMAL	HIGH	
3. TIMER SPEED	SLOW	NORMAL	FAST	FASTEST	
4. GAME SPEED	NORMAL	TURBO 1	TURBO 2	FREE SELECT 1	FREE SELECT 2
5. MAX ROUND	1 ROUND	3 ROUNDS		5 ROUNDS	
6. EVENT	OFF			1 MATCH	
7. AUTOMATIC	OFF			FREE SELECT	

NOTE: FACTORY SETTING

JAMMA CONNECTIONS

SOLDER SIDE		COMPONENT SIDE	
GND	A	1	GND
GND	B	2	GND
+5 VDC	C	3	+5 VDC
+5 VDC	D	4	+5 VDC
N.C.	E	5	N.C.
+12 VDC	F	6	+12 VDC
KEY	H	7	KEY
N/C	J	8	COIN COUNTER 1
COIN LOCK 2	K	9	COIN LOCK 1
*SPEAKER (-)	L	10	*SPEAKER (+)
N.C.	M	11	N.C.
VIDEO GREEN	N	12	VIDEO RED
VIDEO SYNC	P	13	VIDEO BLUE
SERVICE (FREE CREDIT)	R	14	VIDEO GND
N/C	S	15	TEST MODE (DIAGNOSTICS)
2 PLAYER - COIN	T	16	1 PLAYER - COIN
2 PLAYER - START	U	17	1 PLAYER - START
2 PLAYER - UP	V	18	1 PLAYER - UP
2 PLAYER - DOWN	W	19	1 PLAYER - DOWN
2 PLAYER - LEFT	X	20	1 PLAYER - LEFT
2 PLAYER - RIGHT	Y	21	1 PLAYER - RIGHT
2 PLAYER - PUNCH (JAB)	Z	22	1 PLAYER - PUNCH (JAB)
2 PLAYER - PUNCH (STRONG)	a	23	1 PLAYER - PUNCH (STRONG)
2 PLAYER - PUNCH (FIERCE)	b	24	1 PLAYER - PUNCH (FIERCE)
N/C	c	25	N/C
N/C	d	26	N/C
GND	e	27	GND
GND	f	28	GND

*NOTE : FOR CABINETS EQUIPPED WITH CAPCOM® "Q" SOUND, AUDIO CONNECTIONS ARE MADE THROUGH THE A-CARTRIDGE WITH RCA-TYPE CONNECTORS.

AUXILIARY CABLE CONNECTIONS

WIRE COLOR	CONNECTOR ODD ROW			CONNECTOR EVEN ROW	WIRE COLOR
	N/C	1	2	N/C	
	N/C	3	4	N/C	
	N/C	5	6	N/C	
	N/C	7	8	N/C	
PURPLE/YELLOW	2 PLAYER - KICK (ROUNDHOUSE)	9	10	N/C	
	N/C	11	12	N/C	
	N/C	13	14	N/C	
PINK	1 PLAYER - KICK (ROUNDHOUSE)	15	16	N/C	
RED	1 PLAYER - KICK (FORWARD)	17	18	N/C	
BLUE	1 PLAYER - KICK (SHORT)	19	20	N/C	
GRAY/YELLOW	2 PLAYER - KICK (SHORT)	21	22	N/C	
PINK/YELLOW	2 PLAYER - KICK (FORWARD)	23	24	N/C	
	N/C	25	26	N/C	
	N/C	27	28	N/C	
GRAY/YELLOW	TEST BRKT-VOLUME UP	29	30	TEST BRKT-VOLUME DOWN	PINK/YELLOW
BLACK/WHITE	TEST BRKT-VOLUME COMMON	31	32	N/C	
BLACK	1 PLAYER - KICK (COMMON)	33	34	1 PLAYER - KICK (COMMON)	BLACK

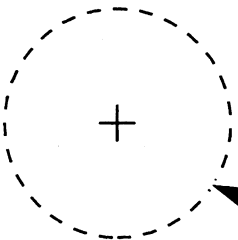

1-3/16" DRILL FOR
1P OR 2P START
BUTTON SWITCH

1-3/4" DRILL FOR
JOYSTICK HOLE

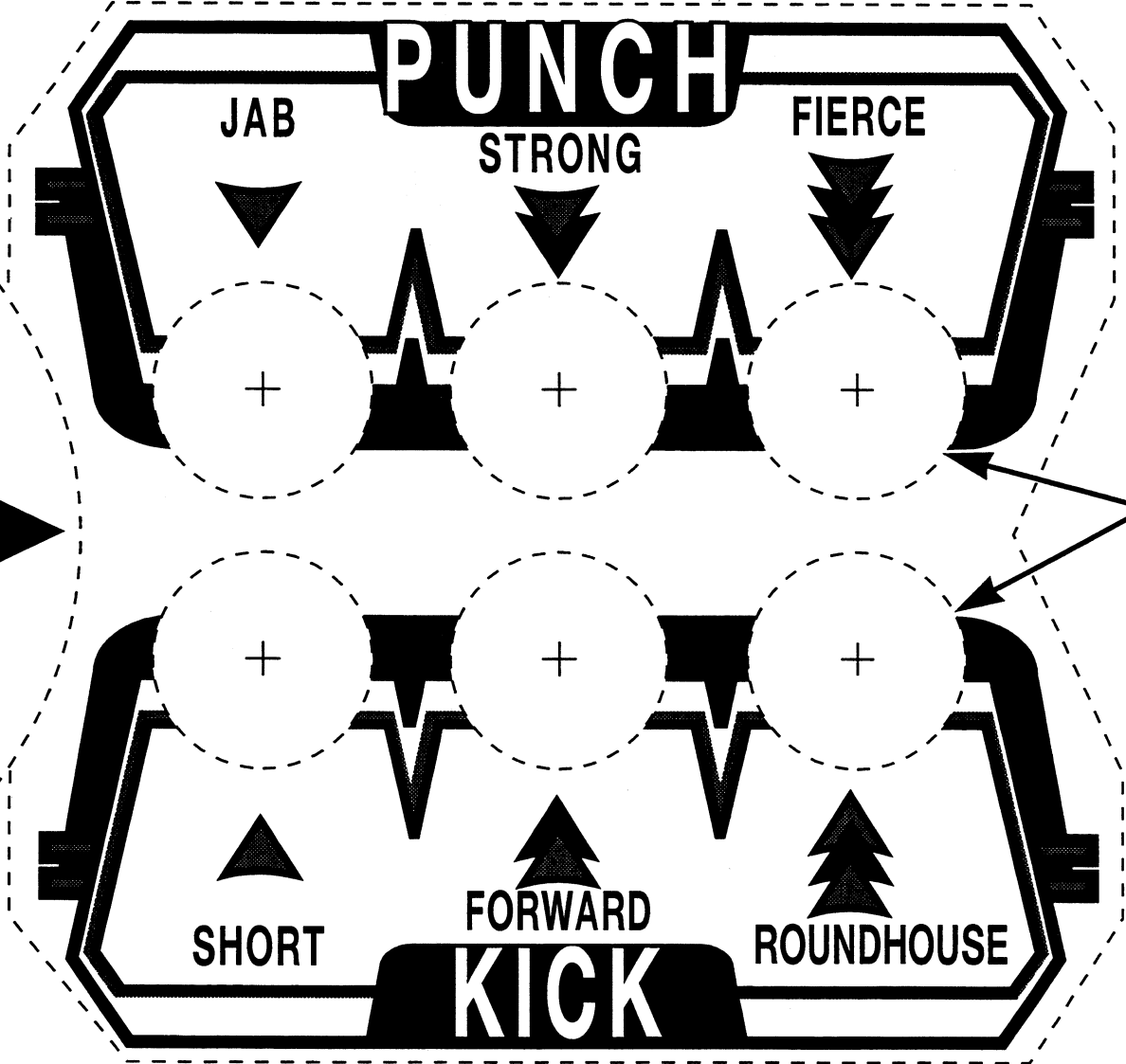
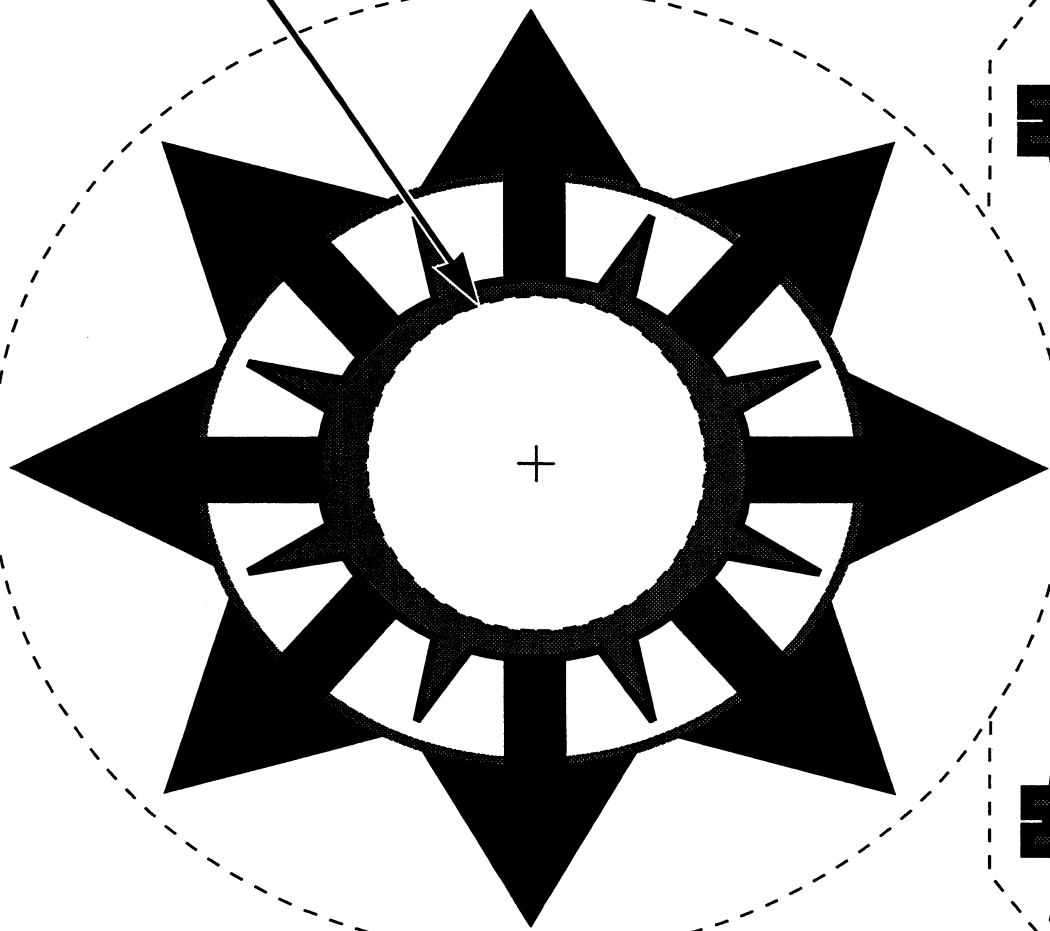

1-3/16" DRILL FOR
BUTTON SWITCH HOLES

CAPCOM[®]
COIN-OP, INC.

CAPCOM COIN-OP, INC.
3311 NORTH KENNICOTT AVENUE
ARLINGTON HEIGHTS, ILLINOIS 60004
PHONE (708) 797-6100
FAX (708) 797-6119

TITLE		DRILL HOLE TEMPLATE: "STREET FIGHTER ALPHA 2"	
DATE	3-19-96	DRAWN BY:	JA
	V110100	REV.	

REFERENCE INFORMATION

GAME CASE CONTROLS

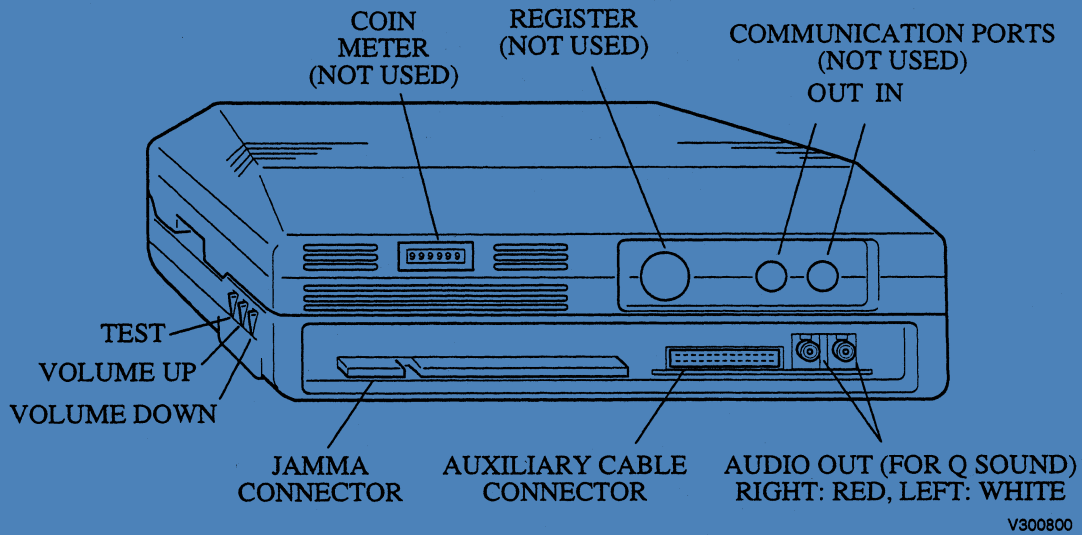

TYPICAL CONTROL PANEL LAYOUT OF *STREET FIGHTER™ : ALPHA 2*

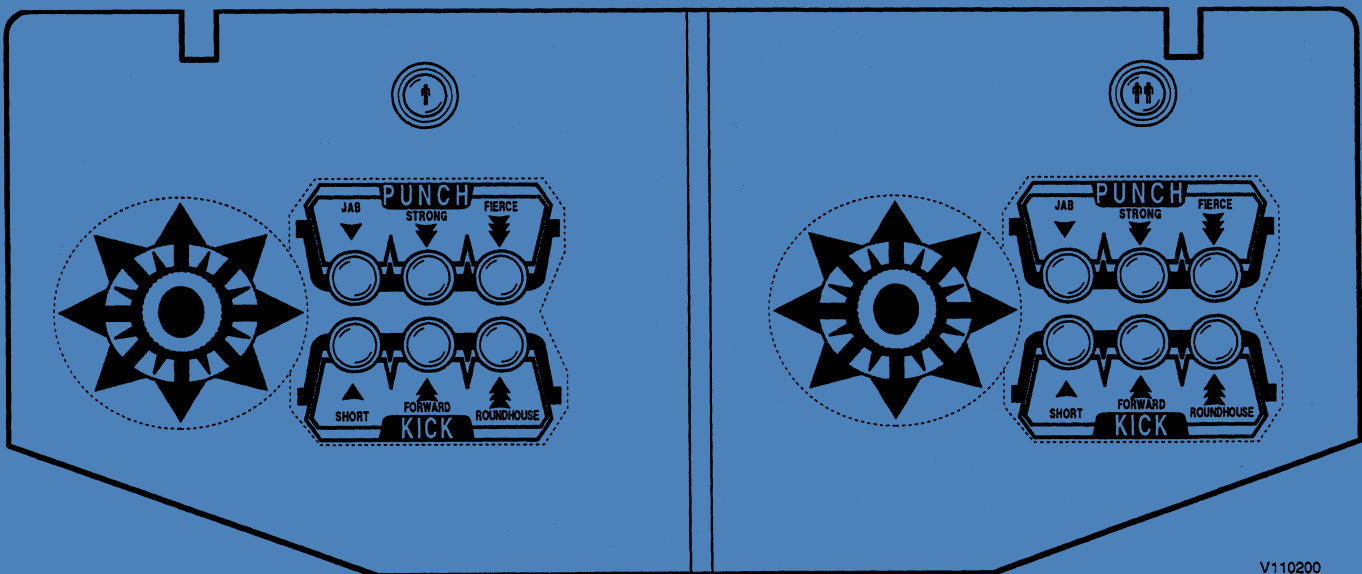

NOTICE

This equipment has been tested and found to comply with the limits for a Class A digital device, pursuant to Part 15 of the FCC Rules. These limits are designed to provide reasonable protection against harmful interference when the equipment is operated in a commercial environment. This equipment generates, uses, and can radiate radio frequency energy and, if not installed and used in accordance with the instruction manual, may cause harmful interference to radio communications. Operation of this equipment in a residential area is likely to cause harmful interference, in which case the user will be required to correct the interference at his own expense.



WARNING

Federal law provides severe civil and criminal penalties for the unauthorized reproduction, distribution, or exhibition of copyrighted audiovisual works and video games.

The Federal Bureau of Investigation investigates allegations of criminal copyright infringement.

CAPCOM[®] COIN-OP, INC.

3311 N. Kennicott Avenue
Arlington Heights, Illinois 60004

Phone: (847) 797-6100

Fax: (847) 797-6306