

SEGA™

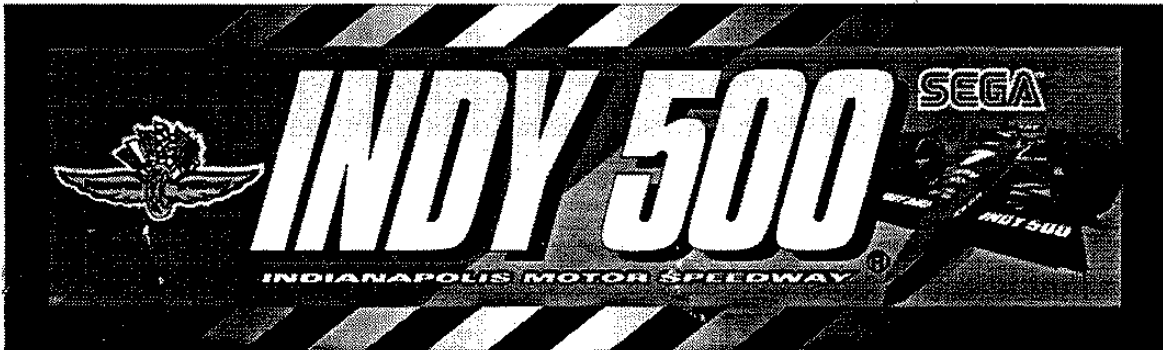

DELUXE OWNER'S MANUAL

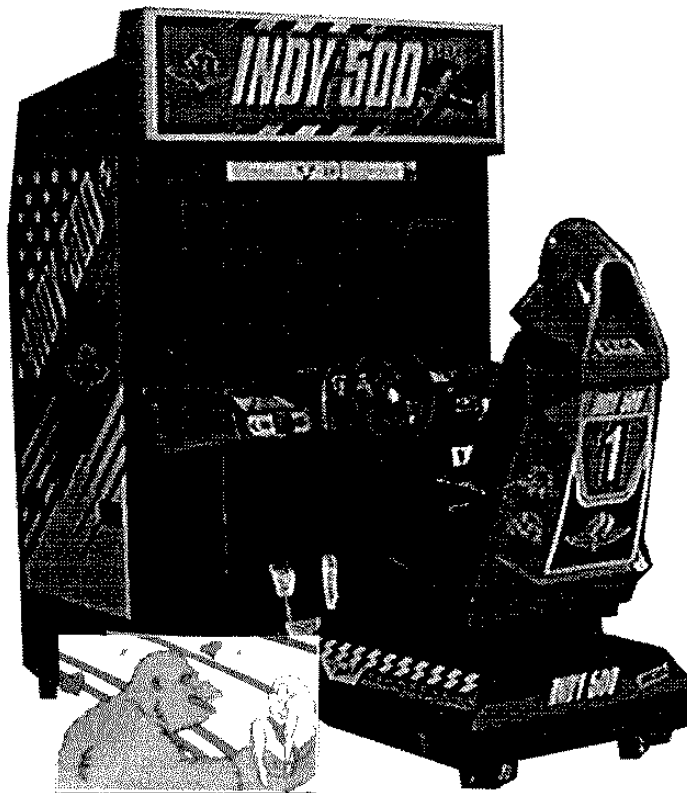

SEGA ENTERPRISES, INC. (USA)

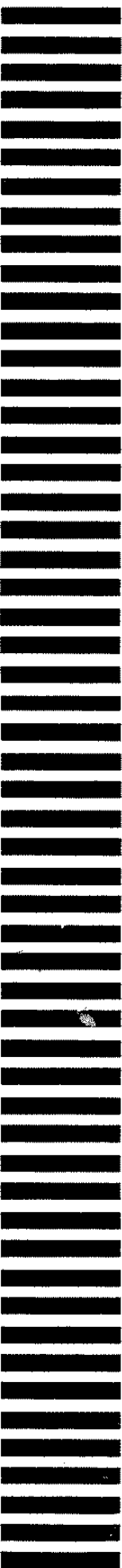

COPYRIGHT NOTICE

This SEGA product has a copyright notice as follows:

© 1996 Sega Enterprises, Inc. (U.S.A.) All rights reserved.

This signifies that this work was disclosed in 1995 and is the property of SEGA ENTERPRISES, INC. (U.S.A.)

Every effort has been made to ensure that this manual is accurate. Sega Enterprises, Inc. (U.S.A.) is not liable for any printing or clerical errors.

Specifications noted herein are subject to change without notice.

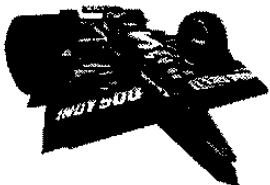
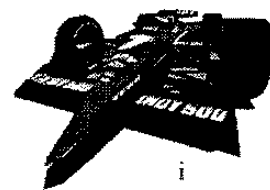

TABLE OF CONTENTS

INTRODUCTION OF THE OWNER'S MANUAL	1
1. PRODUCT SEALS AND SAFETY CERTIFICATION.....	2
2. HANDLING PRECAUTIONS	3
3. INSTALLATION LOCATION PRECAUTIONS	4
4. SPECIFICATIONS.....	5
5. INSTALLATION ITEMS.....	6
6. PRECAUTIONS TO BE HEEDED WHEN ASSEMBLING AND MOVING THE MACHINE	7 ~13
7. HOW TO PLAY	14
8. EXPLANATION OF TEST AND DATA DISPLAY	15~32
8-1 SWITCH UNIT.....	16
8-2 TEST MODE.....	17
8-3 MEMORY TEST.....	18
8-4 T.G.P TEST.....	19
8-5 INPUT TEST.....	20
8-6 OUTPUT TEST.....	21
8-7 SOUND TEST.....	22
8-8 C.R.T. TEST.....	23
8-9 GAME ASSIGNMENTS.....	24~25
8-10 COIN ASSIGNMENT.....	26~29
8-11 VOLUME SETTING.....	30
8-12 BOOKKEEPING.....	31
8-13 BACKUP DATA CLEAR	32
9. CONTROL PANEL	33~35
9-1 REMOVING THE CONTROL PANEL.....	33
9-2 ADJUSTING AND REPLACING THE VOLUME.....	34~35
9-3 GREASING.....	35
10. SHIFT LEVER	36
10-1 REMOVING THE SHIFT LEVER.....	36
10-2 SWITCH REPLACEMENT.....	36
10-3 GREASING.....	36
11. ACCELERATOR & BRAKE	37~38
11-1 ADJUSTING AND REPLACING THE VOLUME.....	37~38
11-2 GREASING.....	38
12. COIN SELECTOR	39
13. PROJECTOR	40~44
13-1 REMOVING THE MONITOR MASK.....	40~41
13-2 CLEANING THE MONITOR MASK.....	41
13-3 CLEANING THE SCREEN.....	41
13-4 ADJUSTING THE PROJECTOR.....	42~44
14. REPLACEMENT OF FLUORESCENT LAMP	45
15. PERIODIC CHECK	46
16. TROUBLESHOOTING	47~48
17. GAME BOARD	49~51
17-1 REMOVING THE BOARD.....	49
17-2 COMPOSITION OF GAME BOARD.....	50
17-3 INPUT AND OUTPUT RELATIONS.....	50~51
18. DESIGN RELATED PARTS	52~53
19. COMMUNICATION PLAY	54~58
19-1 INSTALLATION PRECAUTIONS.....	54
19-2 CONNECTING THE COMMUNICATION CABLES.....	55~56
19-3 SETTING COMMUNICATION PLAY.....	57
19-4 APPLICATION OF STICKER.....	58
20. PARTS LIST.....	59-81
21. WIRING DIAGRAM	83-89
22. VIRTUA COP 2 DELUXE MANUAL COMMENTS	90



INTRODUCTION OF THE OWNER'S MANUAL

SEGA ENTERPRISES, LTD., supported by its high technology semiconductors, microprocessors, etc. and a wealth of experience, has for more than 30 years been supplying various innovative and popular game machines to the world market. This Owner's Manual is intended to provide detailed descriptions together with all the necessary servicing control, spare parts, etc. related to the Indy 500 Deluxe, a new SEGA product.

This manual is intended for those who have knowledge of electricity and technical expertise, especially in ICs, CRTs, microprocessors, and circuit boards. Read this manual carefully to acquire sufficient knowledge before working on the machine. Should there be a malfunction, nontechnical personnel should under no circumstances touch the interior system. Should the need arise, contact our Main Office or the closest branch office listed:

SEGA ENTERPRISES, INC. (U.S.A.)

Customer Service

41533 Industrial Drive

Fremont, CA 94538 USA

Phone (415) 802-1750

FAX: (415) 802-1754

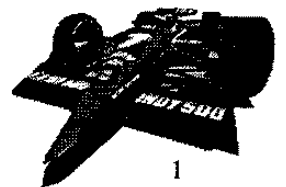

1. PRODUCT SEALS AND SAFETY CERTIFICATION

PRODUCT LABELING

To prevent counterfeits and conversions, the following labels are put on all SEGA products. When handling such goods, be sure to confirm the labels. They are used to prevent illegal acts such as the unauthorized copying of merchandise or by converting, selling or using products or printed circuit boards.

ORIGINAL SEAL

The following seal is put on all machines manufactured by SEGA.



LICENSE SEAL

The following seal is put on all SEGA kits, such as printed circuit boards.



SAFETY CERTIFICATION

UL[®] Listed Amusement Machine: Model SUR-017D-001
FCC Part 15 Subpart J, class A

This equipment has been tested and found to comply with the limits for a Class A digital device in accordance with the specifications in Part 15 of the FCC rules. Operation is subject to the following two conditions: (1) This device may not cause harmful interference, and (2) this device must accept any interference received, including interference that may cause undesired operation.

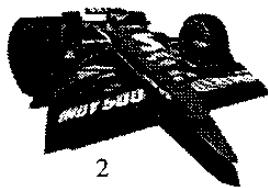

2. HANDLING PRECAUTIONS

When installing or inspecting the machine, be aware of the following safety items. Pay attention so that the players can enjoy the game safely.

- Turn the power off before working on the machine.
- Do not insert or pull out the plug quickly.
- Make sure that the power cord and ground wire are not exposed during transportation. Make sure that all ground connections are made safely at the installation position where specified.
- Do not use any fuse that does not meet the specified rating.
- Make complete connections for the IC board and other connections. Insufficient connections are very dangerous.
- When cleaning the monitor glass, use a soft cloth. Do not apply chemicals such as benzine or thinner.
- Sega Enterprises, Inc. (U.S.A.) is not liable for any damages or injury resulting from use of this equipment in a manner for which it was not designed or intended.

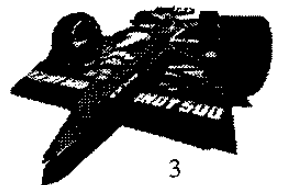

3. INSTALLATION LOCATION PRECAUTIONS

The Indy 500 Deluxe is an indoor game machine. Absolutely do not install it outside. Even indoors, to ensure proper usage, avoid installing in any of the places mentioned below. Follow all of the installation instructions and precautions when installing the machine.

LOCATION PRECAUTIONS:

- Places subject to rain or water leakage, or condensation due to humidity.
- In the proximity of an indoor swimming pool and/or shower.
- Places subject to direct sunlight.
- Places subject to heat sources from heating units or hot air.
- In the vicinity of highly inflammable/volatile chemicals or hazardous matter.
- On sloped surfaces.
- In the vicinity of anti-disaster facilities such as fire exits and fire extinguishers.
- Places subject to any type of violent impact.
- Dusty places.

INSTALLATION PRECAUTIONS:

- Do not insert more than one electrical plug into the power plug socket.
- The per unit standard voltage/amperage is 120V/10A.
- Use of extension cords should be avoided. If you must use an extension cord, ensure the extension cord is rated at 15A or higher.
- For transporting the machine into the location's building, the minimum necessary dimensions of the opening (doors, etc.) are 30 in. (W) x 80 in. (H).
- For operation of the machine, the minimum installation dimensions are 26 in. (W) x 40 in. (D).
- Due to its size and weight, use at least four (4) people to uncrate this game.

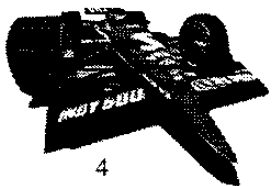

4. SPECIFICATIONS

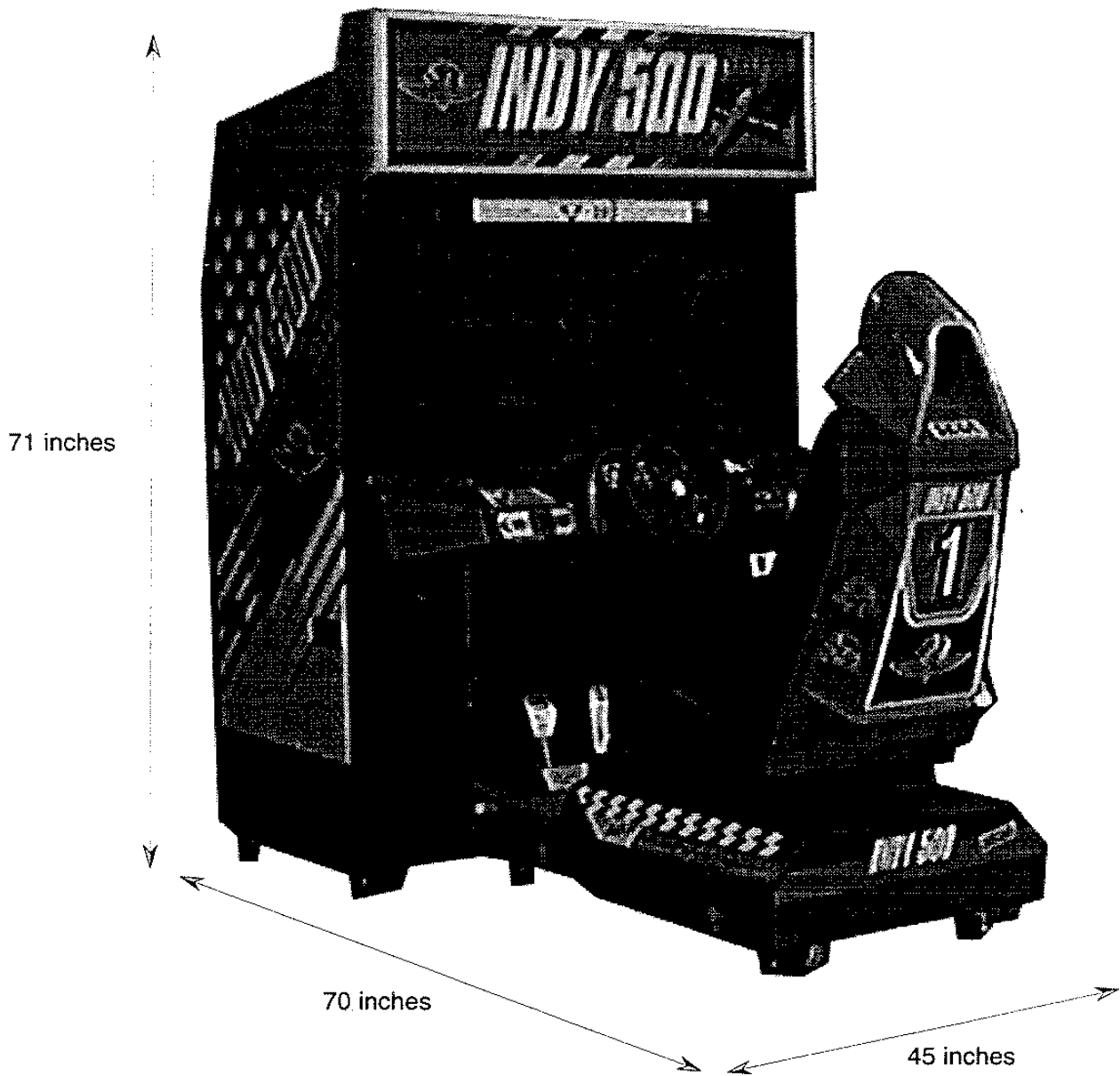
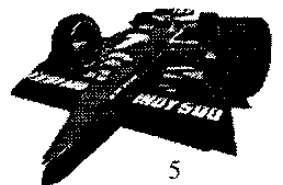

FIGURE 1: INDY 500 DELUXE INSTALLATION DIMENSIONS

Table 1: Indy 500 Deluxe Specifications

TYPE	SPECIFICATION
Dimensions, Crated	29 in. (W) x 42 in. (D) x 72 in. (H)
Dimensions, Installed	26 in. (W) x 39 in. (D) x 71 in. (H)
Weight	375 lbs.
Power, Current	360 Watts, 3A (MAX.)
Monitor Type	39 inch, Projection Monitor, Medium Resolution



5. INSTALLATION

The items listed in Table 2 are supplied with the Indy 500 Deluxe and should be included with the machine whenever the machine is moved.

TABLE 2: INSTALLATION ITEMS

PART NAME	QTY.	LOCATION
Owner's Manual - Indy 500 Deluxe	1	In Cash Box
Linking Cable (Fiber Optic)	1	In Cash Box
Fuse	1	In Cash Box
Remote Control	1	In Cash Box
Seat Sticker Set (2- 8)	1	In Cash Box
Seat Mounting Hardware:		In Cash Box
Bolts	8	
Lock Washers	8	
Flat Washers	8	
L-Brackets	2	
Torx Anti-Tamper Wrenches:		In Cash Box
M5	1	
M8	1	
Keys:		
Coin Mech Door	2	Strapped to Controls
Cash Box	2	Behind Coin Mech Door
Rear Access Panel	2	Behind Coin Mech Door

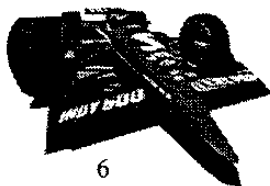

6. PRECAUTIONS TO BE HEEDED WHEN ASSEMBLING AND MOVING THE MACHINE



WARNING!

- Perform the assembly work by following the procedure herein stated. Failing to comply with the instructions, for example, inserting the plug into an outlet at the stage not mentioned in this manual can cause an electric shock accident.
- Assembling should be performed as per this manual. Since this is a complex machine, erroneous assembling can cause damage to the machine or malfunctioning to occur.
- When assembling, be sure to perform the work by plural persons. Depending on the assembly work, there are some cases in which performing the work by a single person can cause personal injury or parts damage.

When performing the assembly work, follow the procedure sequentially in order-of the 5 items below:

- 1** ASSEMBLING THE CABINET
- 2** SECURING IN PLACE (LEG ADJUSTER ADJUSTMENT)
- 3** POWER SUPPLY
- 4** TURNING THE POWER ON
- 5** ASSEMBLY CHECK

Note that the Master Key (an accessory) in addition to the tools such as a plus driver, wrench for M16 Hexagon Bolt and socket wrench is required.

1 ASSEMBLING THE CABINET



Since the Cabinet is moved during the assembly work, be sure to proceed the work in such a place where the floor is level and does not have step-like differences, with each of the cabinet casters making contact with the surface.

- ① Secure the 2 L type Brackets to the Rear Cabinet with 2 Hexagon Bolts (black) for each (bracket).

Hexagon Bolt (black) (4)
M8×20, w/ flat & spring washer

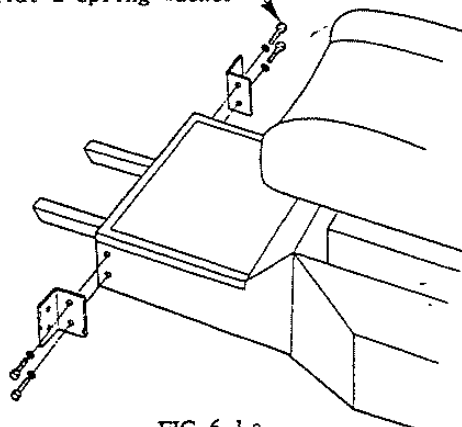

FIG. 6.1 a

- ② Insert the Rear Cabinet's square pipe into the Front Cabinet's square hole. At this time ensure that the pipe is inserted up to the point approximately 10 cm. before the innermost end of the hole.

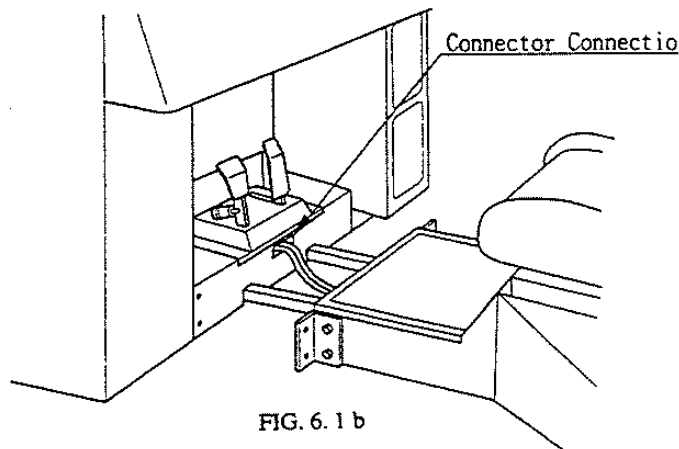

FIG. 6.1 b

- ③ Take out the wiring (3P white connector, 2P black connector) from the Rear Cabinet and connect the wiring to the Front Cabinet's Connector Panel, and then ensure that the Rear Cabinet and the Front Cabinet meet tightly without any clearance, by paying careful attention so that the wiring is not caught in between.

- ④ Firmly secure the L type Bracket secured as per ① above by using the 4 Hexagon Bolts.

Hexagon Bolt (black) (4)
M8×20, w/flat & spring washer

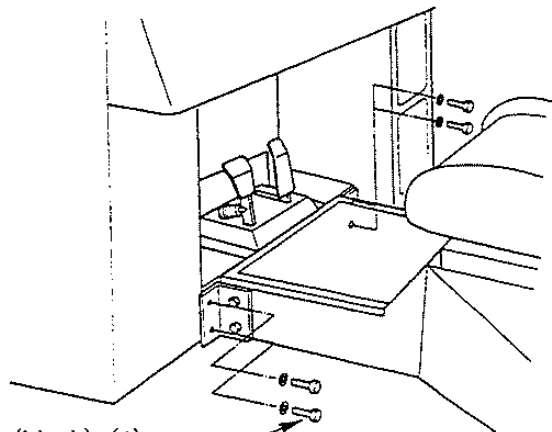

FIG. 6.1 c

2 SECURING IN PLACE (LEG ADJUSTER ADJUSTMENT)



Make sure that all of the leg adjusters are in contact with the floor. If they are not, the cabinet may move causing an accident.

This machine has 8 casters (four each for the front cabinet, the rear cabinet) and 6 leg adjusters (4 for the front cabinet, 2 for the rear cabinet) (Fig. 6.2a). When the installation position is determined, cause the leg adjusters to come into contact with the floor directly, make adjustments in a manner so that the casters will be raised approximately 5mm. from the floor and make sure that the machine position is level.

- ① Move the machine to the installation position. When installing the machine against or close to a wall, be sure to secure a passage space to enable the player to take a ride in the machine.
- ② Cause all of the leg adjusters to make contact with the floor. By using a wrench, make adjustments in the height of the leg adjusters to ensure that the machine's position is level.
- ③ After making adjustments, fasten the leg adjuster nut upward and secure the height of the leg adjuster (Fig. 6.2b).

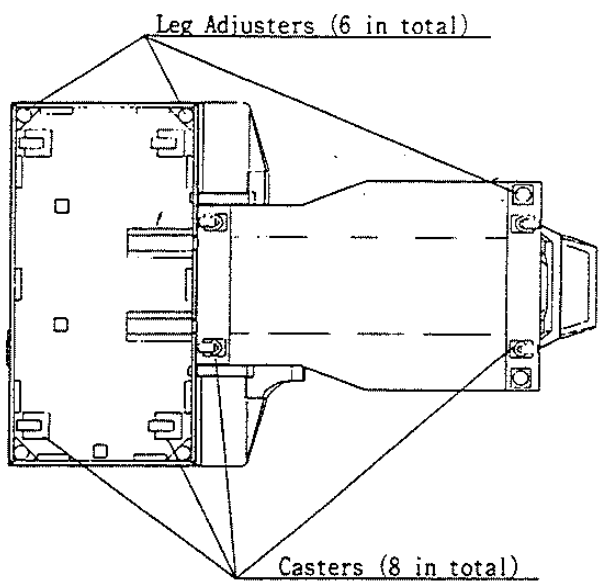

FIG. 6.2 a

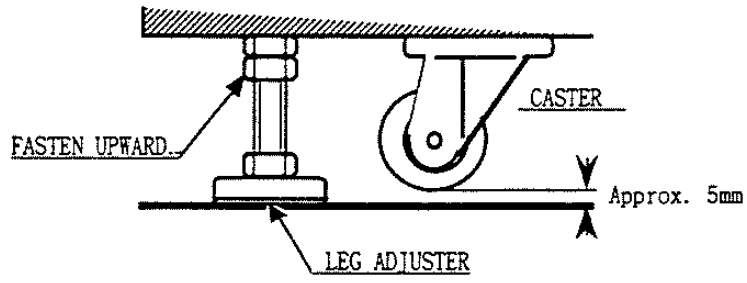

FIG. 6.2 b LEG ADJUSTER

3 POWER SUPPLY



- Be sure to ground the Earth Terminal. Unless it is appropriately grounded, an electric shock accident can be caused to the customers.
- Ensure that the power cord and Earth Wire are not exposed. If exposed, they are susceptible to damage and if they are damaged, electric shock or a short circuit can be caused.
- Ensure that the power supply is equipped with a Circuit Protector. Using the power supply which is not equipped with the Circuit Protector can cause a fire resulting from a short circuit.

The AC Unit is positioned on the left-hand side rear of the Front Cabinet. Connect the AC Unit's Earth Terminal and the "accurately grounded indoor earth terminal" by using the Earth Wire.

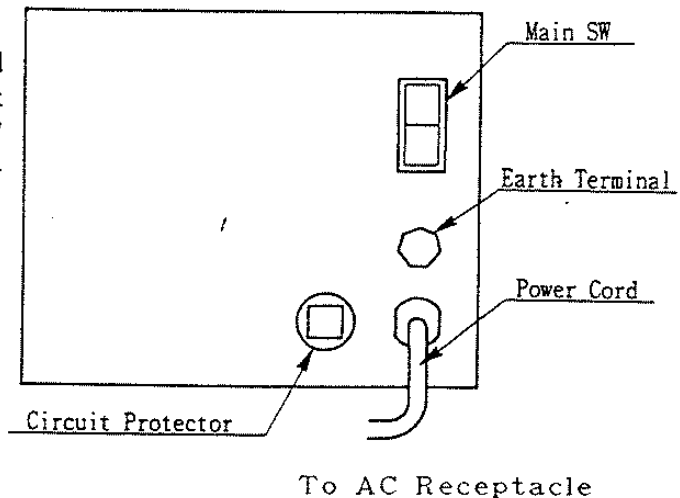

FIG. 6.3

4 TURNING ON POWER

Turning the AC unit's MAIN SW on will cause the machine to start the POWER ON check automatically. The steering wheel turns left and right, then returns to the centering position and stops. In this check, the values of V. R. inside the control panel are corrected. Until the check is finished (the steering wheel stops automatically), do not touch the steering wheel or play the game.

If you do, the steering wheel reaction during the game (reaction at the time of a course-out or crashing) can not be obtained correctly.

In a case of a strange reaction during the game, turn on power again from the beginning and complete the power-on check.

For communication play, the network check is performed after the power is turned on and the screen display will show the check mode. For details, refer to Section 19.

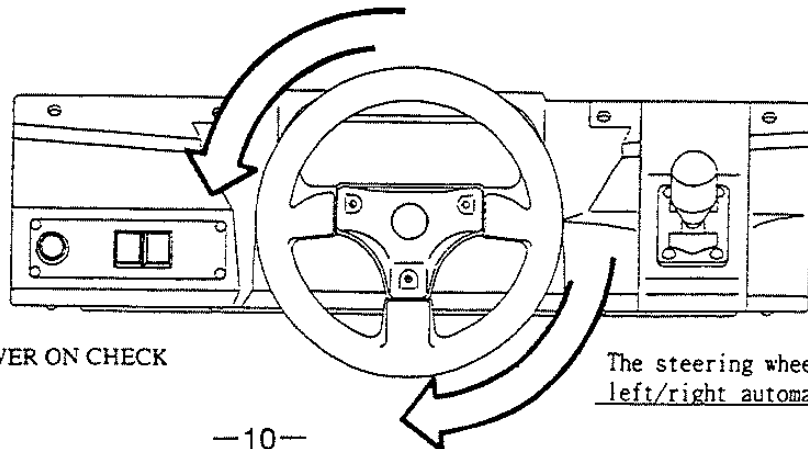

FIG. 6.4 POWER ON CHECK

The steering wheel turns left/right automatically.

5

ASSEMBLY CHECK

In the TEST MODE, ascertain that the assembly has been made correctly and IC BD. is satisfactory (refer to Section 8).

In the test mode, perform the following test:

(1) MEMORY TEST

MEMORY TEST			
<ROM>			
IC15 GOOD	IC16 GOOD		
IC11 GOOD	IC12 GOOD		
IC9 GOOD	IC10 GOOD		
IC7 GOOD	IC8 GOOD		
<RAM>			
IC14 GOOD	IC15 GOOD	IC16 GOOD	IC17 GOOD
IC18 GOOD	IC19 GOOD		
IC98 GOOD	IC150 GOOD		
IC79 GOOD	IC80 GOOD		
IC81 GOOD	IC83 GOOD	IC82 GOOD	IC84 GOOD
IC88 GOOD	IC89 GOOD		
IC91 GOOD	IC92 GOOD	IC93 GOOD	
IC27 GOOD	IC29 GOOD	IC28 GOOD	IC30 GOOD

PRESS TEST BUTTON TO EXIT

Selecting the MEMORY TEST on the test mode menu screen causes the on-board memory to be tested automatically. The game board is satisfactory if the display beside each IC No. shows GOOD. ✓

(2) INPUT TEST

INPUT TEST	
STEERING WHEEL	80H
GAS PEDAL	30H
BRAKE PEDAL	30H
SHIFT UP	OFF
SHIFT DOWN	OFF
VIEW1 (ZOOM IN)	OFF
VIEW1 (ZOOM OUT)	OFF
START	OFF
COIN CHUTE	OFF
SERVICE	OFF
TEST	OFF

PRESS TEST BUTTON TO EXIT

Selecting the INPUT TEST on the test mode menu screen causes the screen (on which each switch and V. R. are tested) to be displayed. Press each switch. For the coin switch test, insert a coin from the coin inlet with the coin chute door being open. If the display beside each switch indicates "ON," the switch and wiring connections are satisfactory.

Ascertain the display of V. R. value for the steering wheel and accelerator & brake. If the V. R. values are not satisfactory, refer to Sections 9 & 10.

(3) OUTPUT TEST

OUTPUT TEST	
CENTERING LEVEL	0
START LAMP	OFF
VIEW1 LAMP (ZOOM IN)	OFF
VIEW2 LAMP (ZOOM OUT)	OFF
->EXIT	
SELECT WITH SERVICE BUTTON AND PRESS TEST BUTTON	

In the output test mode, carry out lamp test to ascertain that each lamp lights up satisfactorily.

(4) SOUND TEST

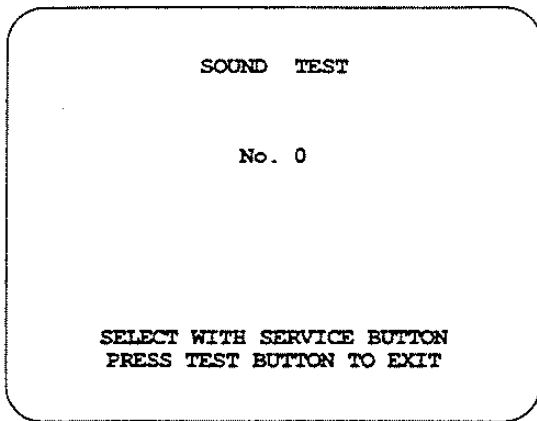

In the TEST mode, selecting SOUND TEST causes the screen (on which sound related BD and wiring connections are tested) to be displayed.

Be sure to check if the sound is satisfactorily emitted from each speaker and the sound volume is appropriate.

(5) C.R.T. TEST

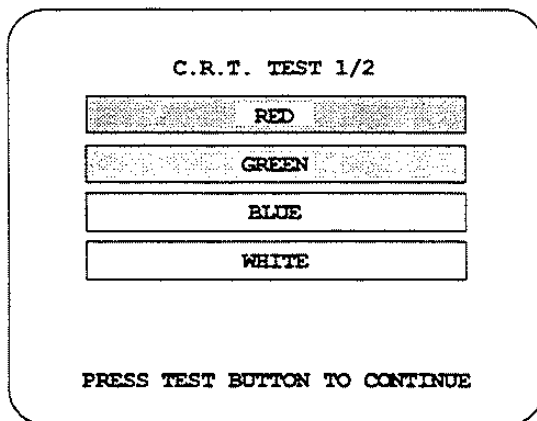

In the TEST mode menu, selecting C.R.T. TEST allows the screen (on which the projector is tested) to be displayed. Although the projector adjustments have been made at the time of shipment from the factory, color deviation, etc., may occur due to the effect caused by geomagnetism, the location building's steel frames and other game machines in the periphery. By watching the test mode screen, make judgment as to whether an adjustment is needed. If it is necessary, adjust the projector by referring to Section 13.

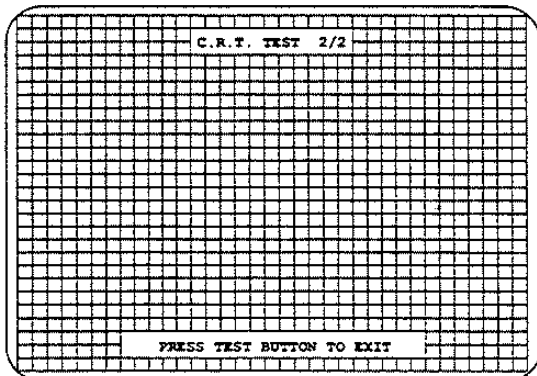

Perform the above inspections also at the time of monthly inspection.

CAUTION TO BE HEDED WHEN MOVING THE MACHINE

The weight of this machine is approximately 306 kg. When moving the machine on the floor, retract the Leg Adjusters to have the Casters make contact with the surface. When moving the machine in places where there are step-like differences, be sure to separate the Front Cabinet and the Rear Cabinet. Lifting the Cabinet in a status as is connected can damage the Cabinet.

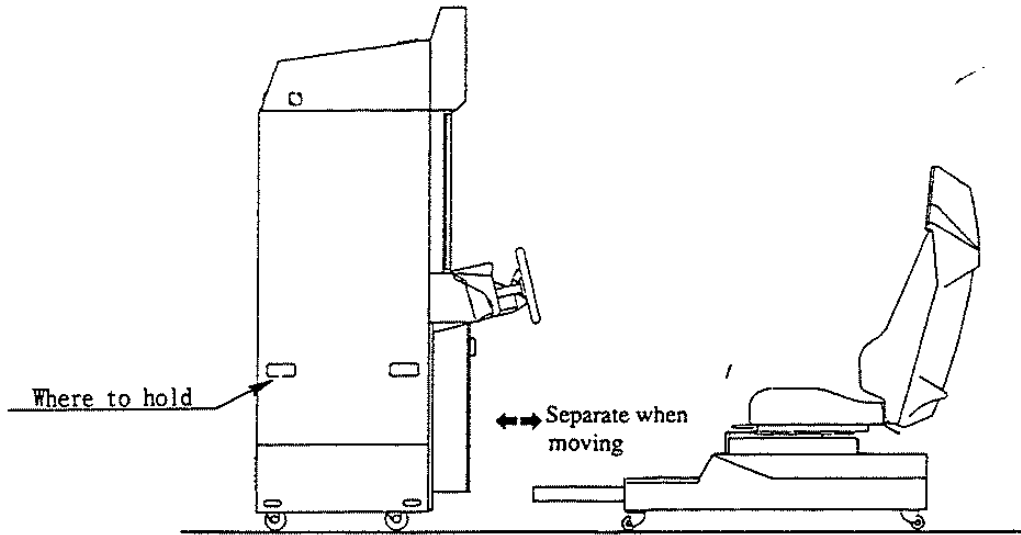

FIG. 6.4

7. HOW TO PLAY

- ① First choose one from among the 3 Courses (the explanations of the 3 courses are given later). Turn the Steering Wheel to choose the desired course and make the selection effective by stepping on the Accelerator (Gas Pedal) or pressing the Start Button.
- ② When plural machines are interacting, wait for the other player's entry in this screen mode. After all of the players choose their desired courses, a course is determined by a majority decision. In case of a tie, the course will be determined sequentially in priority order of INDY 500, HIGHLAND RACEWAY, and BAY SIDE STREET.
- ③ Next, select either of the 2 transmissions, AT (auto) or MT (6-shift manual) in the same manner as in Course selection (turn the steering wheel to choose and step on the Accelerator or press the Start Button to make the selection effective).
- ④ After the above 2 steps are determined, the game proceeds with a rolling start applicable for all the 3 courses.
- ⑤ There are 1 ~ 3 checkpoints (varies depending on courses). Passing a checkpoint within the limited time gives the player a time extension.
- ⑥ If the player fails to pass the checkpoint within the time limit or if he finishes running the specified number of laps of each course, the game is over.
- ⑦ During the race, 4 types of perspectives can be shifted by using the View Button.
- ⑧ Pressing the Start Button during the race allows the position of on-screen cars to be indicated above that particular car. Press the Start Button again to return to the previous status.
- ⑨ If the player finishes up to the last and if the total time is satisfactory, name entry up to 10th position per course is allowed.

Features of each course

■ INDY 500

Number of Laps 4 Number of Checkpoints 1

This course reproduces the actual Indianapolis Motor Speedway. It's an oval course very close to a rectangular shape.

■ HIGHLAND RACEWAY

Number of Laps 3 Number of Checkpoints 2

This is an imaginary course on which the machines run through the folds of hills. Sharp ups and downs are the features of this course.

■ BAY SIDE STREET

Number of Laps 3 Number of Checkpoints 3

Players run through an urban area on this imaginary course. Both sides of the road are concrete walls. This one is the most difficult of all three courses.

*The number of Laps are initialized and can be changed in the test mode.

Course Selection Screen

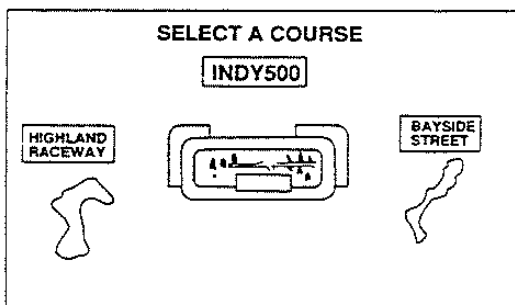
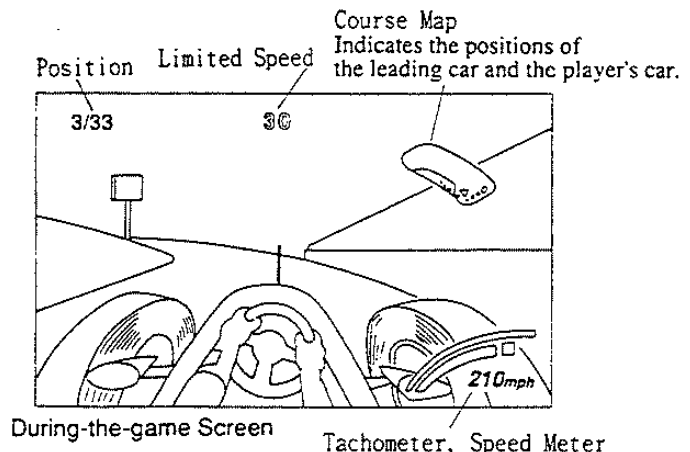

FIG. 7



During-the-game Screen

Tachometer, Speed Meter

8. EXPLANATION OF TEST AND DATA DISPLAY

By operating the switch unit, periodically perform the tests and data check. When installing the machine initially or collecting cash, or when the machine does not function correctly, perform checking in accordance with the explanations given in this section. The following shows tests and modes that should be utilized as applicable.



In the case where multiple units are linked for communication play, exiting from the test mode causes the unit to perform the network check automatically. During this time, all of the linked units will not allow the game to be played in normal status.

Therefore, be sure not to enter the test mode if any one of the units is in play. On the other hand, if even one unit is in the test mode, make sure that other machines are not in play.

TABLE 8 EXPLANATION OF TEST MODE

ITEMS	DESCRIPTION	REFERENCE SECTIONS
INSTALLATION OF MACHINE	When the machine is installed, perform the following: 1. Check to see that each setting is as per standard setting made at the time of shipment. 2. In the INPUT TEST mode, check each SW and VR. 3. In the OUTPUT TEST mode, check each of lamps. 4. In the SELF-TEST mode, check ICs on the IC Board.	8-9, 8-10 8-5 8-6 8-3
MEMORY	Choose MEMORY TEST in the MENU mode to allow the MEMORY test to be performed. In this test, PROGRAM RAMs, ROMs, and ICs on the IC Board are checked.	8-2
PERIODIC SERVICING	Periodically perform the following: 1. MEMORY TEST 2. Ascertain each setting. 3. In the INPUT TEST mode, test the CONTROL device 4. In the OUTPUT TEST mode, check each of lamps.	8-3 8-9, 8-10 8-5 8-6
CONTROL SYSTEM	1. In the INPUT TEST mode, check each SW and VR. 2. Adjust or replace each SW and VR. 3. If the problem can not be solved yet, check the CONTROL's moves.	8-5 9, 10, 11
MONITOR	In the MONITOR ADJUSTMENT mode, check to see if the PROJECTOR adjustment is appropriately made.	8-8 13
IC BOARD	1. MEMORY TEST 2. In the SOUND TEST mode, check the sound related ROMs.	8-3 8-7
DATA CHECK	Check such data as game play time and histogram to adjust the difficulty level, etc..	8-12

8 - 1 SWITCH UNIT

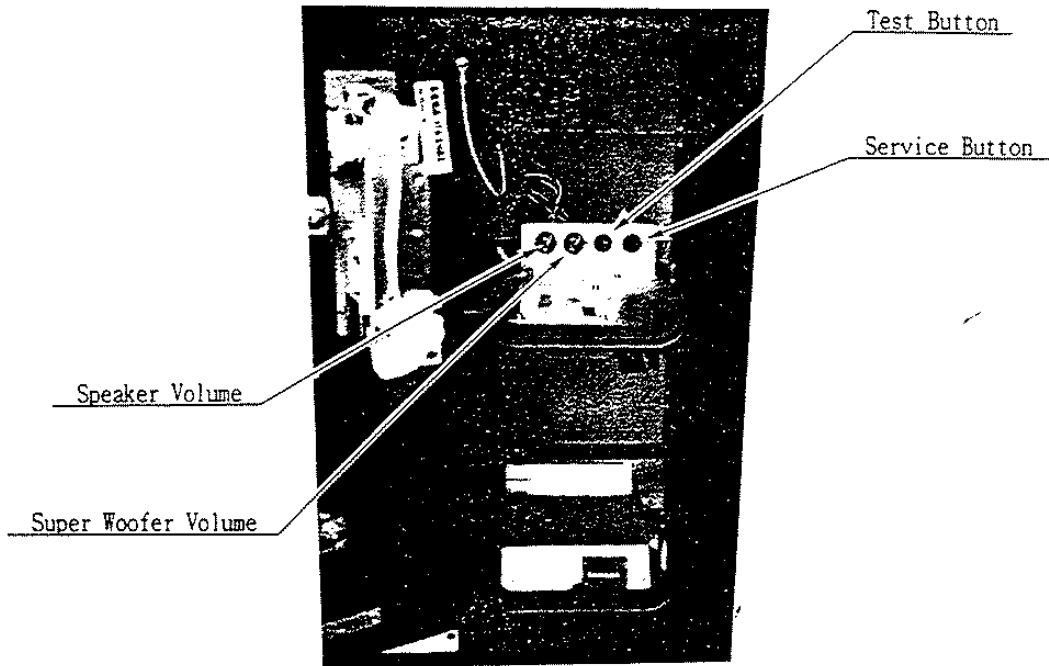

FIG. 8.1 a SW UNIT

Open the coin chute door, and the switch unit shown will appear. The functioning of each SW is as follows:

- | | | |
|--|---|--|
| TEST BUTTON
TEST | : | For the handling of the test button, refer to the following pages. |
| SERVICE BUTTON
SERVICE | : | Gives credits without registering on the coin meter. |
| SPEAKER VOL.
SPEAKER | : | Can adjust the volume of all Speakers of the machine. |
| SUPER WOOFER VOL.
SUPER WOOFER | : | Adjusts only the volume of the Rear Cabinet's Super Woofer. |

The control panel switches are also used in the test mode. For each functioning, refer to the following page and onward.

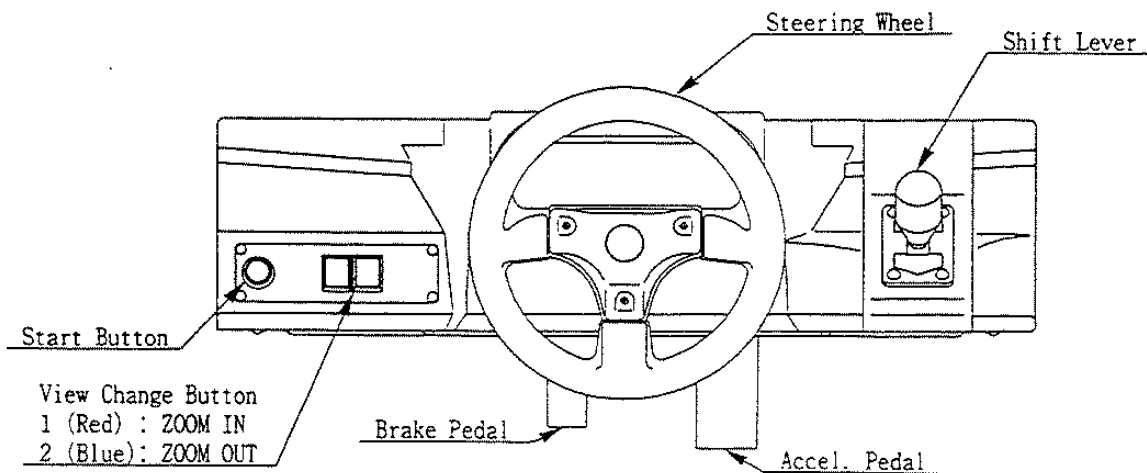

FIG. 8.1 b

8 - 2 TEST MODE

The Test Menu allows the functioning of each part of the Cabinet to be checked, the monitor to be adjusted, and the coins and game related various settings to be performed.

- Press the TEST BUTTON to cause the following Test Menu to be displayed on the monitor. (FIG. 8.2)
- Press the SERVICE BUTTON or VIEW CHANGE BUTTON (VR) until the pointer "->" is moved to the desired item to make a selection.
- Bring the pointer "->" to the desired item and press either the TEST BUTTON or START BUTTON to enter the selected item's test.

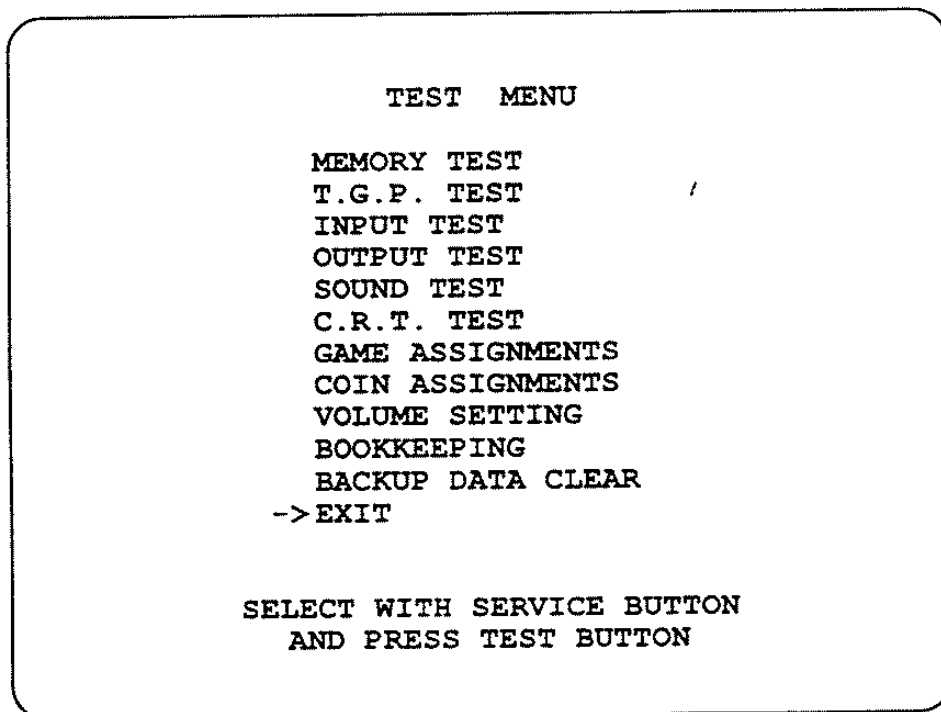

FIG. 8.2 TEST MENU

- After the test is complete, move "->" to "EXIT" and press the TEST BUTTON or START BUTTON to return to the Game Mode.



When changes are made in the settings of GAME ASSIGNMENTS, COIN ASSIGNMENTS and VOLUME SETTING, be sure to exit from the Test Mode to return to the Game Mode. (If the power is turned OFF in the Test Mode, the settings can not be rewritten.)

8 - 3 MEMORY TEST

The MEMORY TEST mode is for checking the on-BD memory IC functioning. "GOOD" is displayed for normal ICs and "BAD" is displayed for abnormal ICs.

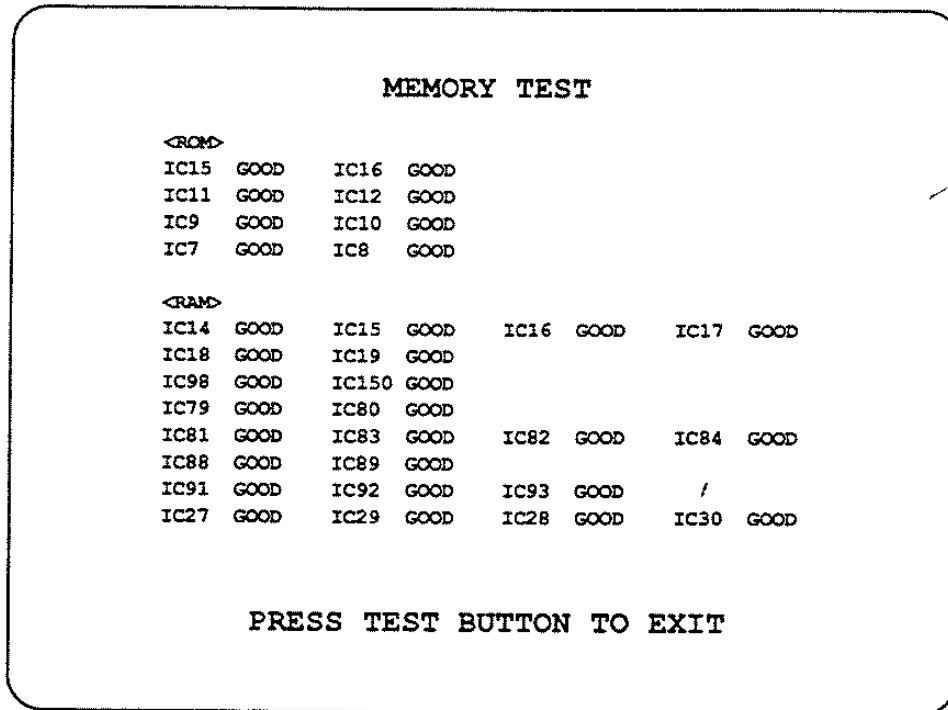

FIG. 8.3 MEMORY TEST

- When the test is completed, if the results are shown as above, it is satisfactory.
- It takes approximately seventy-five seconds to complete the test. If the TEST exceeds seventy-five seconds, the board may have malfunctioned.
- After finishing the test, pressing the TEST BUTTON or START BUTTON to return to MENU mode.

8 - 4 T.G.P. TEST

Selecting T.G.P. TEST causes the functioning of the on-IC-BD T.G.P. (screen display related IC's) to be checked automatically. If the IC is satisfactory, "GOOD" will be indicated and if the IC is not satisfactory, "BAD" will be displayed.

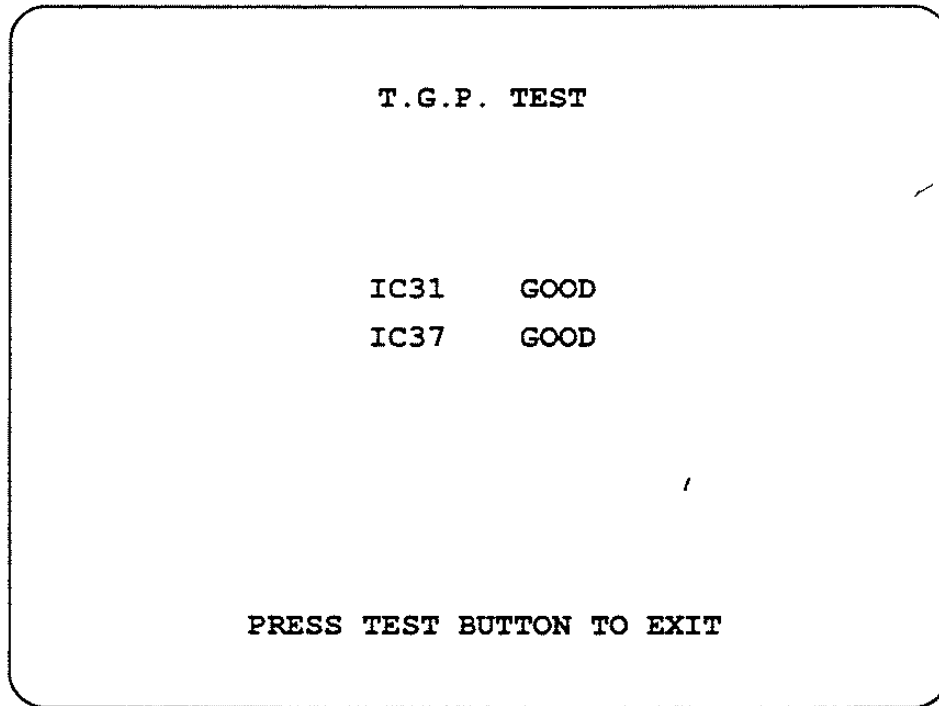

FIG. 8.4 T.G.P. TEST

- After the test is finished, if the above are indicated, it is satisfactory.
- After finishing the test, press the Test button or Start button to return to the Menu screen.

8 - 5 INPUT TEST

When INPUT TEST is selected, the monitor will show the following, allowing you to watch the status of each switch and the value of each V. R. of the CONTROL PANEL. On this screen, periodically check the status of each switch & V. R.

- By pressing each switch, if the display on the right-hand side of the name of each switch changes to ON from OFF, the SW and the wiring connections are satisfactory.
- To check Coin Chute Coin SW, open the Coin Chute Door and insert a coin(s) in the slot.
- To return to the Menu mode, press the Test Button or simultaneously press the Start Button & View Change Button 1 & View Change Button 2.

INPUT TEST	
STEERING WHEEL	80H
GAS PEDAL	30H
BRAKE PEDAL	30H
SHIFT UP	OFF
SHIFT DOWN	OFF
VIEW1 (ZOOM IN)	OFF
VIEW1 (ZOOM OUT)	OFF
START	OFF
COIN CHUTE #1	OFF
COIN CHUTE #2	OFF
SERVICE	OFF
TEST	OFF
PRESS TEST BUTTON TO EXIT	

FIG. 8.5 INPUT TEST

The appropriate values of each V. R. are as follows:

STEERING WHEEL: Under 2DH ← 7D~83H → Over D3H
left (Centering position) right

GAS PEDAL: Under 30H → Over C0H
BRAKE PEDAL: Under 30H → Over C0H
(the pedal released) (the pedal stepped)

8 - 6 OUTPUT TEST

This test allows the Steering Wheel 's centering strength and the status of each lamp to be checked.

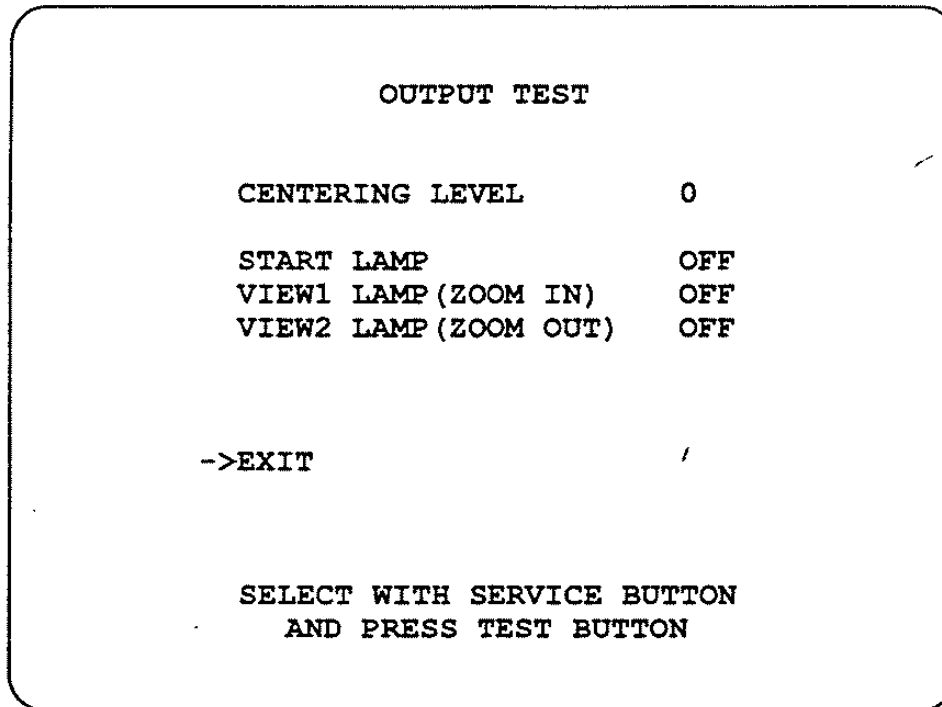

FIG. 8. 6 OUTPUT TEST

TEST PROCEDURE

- ① Press either of the Service Button or the View Change Button to move the arrow -> to the desired test item.
- ② To perform the test, press either the Test Button or the Start Button.
Each time the Test Button is pressed, the CENTERING LEVEL varies from (0 ... Naught to 8 ... strongest) in 9 steps. Check the Steering Wheel's centering strength by changing the centering level.
To check each lamp, bring the arrow to the desired item and press the Test Button . The on-screen display will indicate "ON" and the corresponding lamp attached to the Cabinet lights up.
Press the Test Button again to cause the on-screen display to indicate "OFF" and the lamp to go off.
- ③ Move the arrow to EXIT and press either the Test Button or Start Button to return to the Menu screen.

8 - 7 SOUND TEST

This test mode allows each sound related board and speaker to be checked.

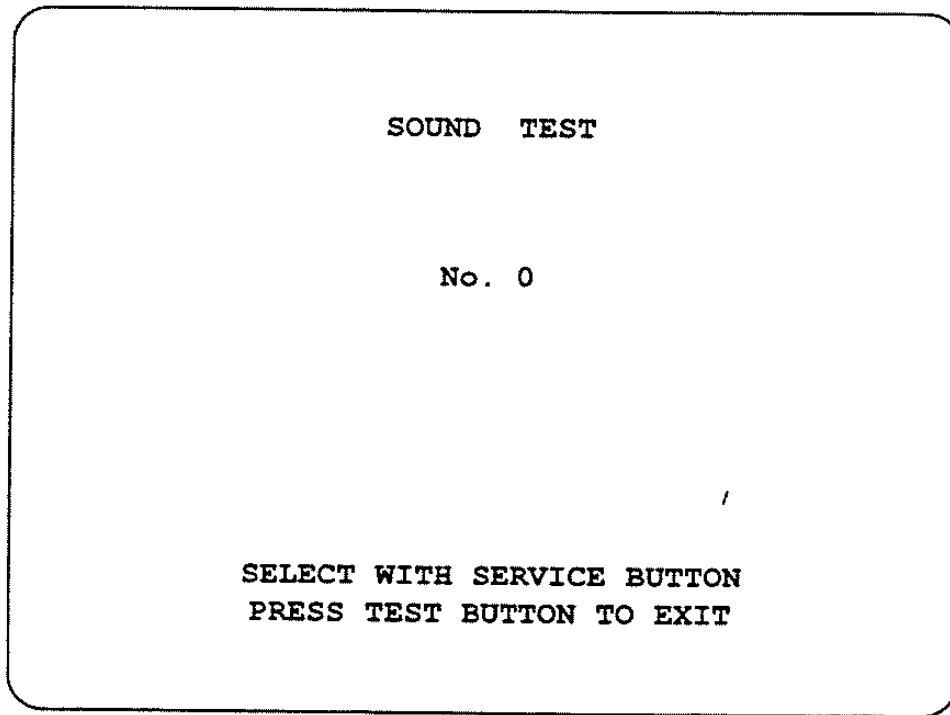

FIG. 8.7 SOUND TEST

- Press either the Service Button or the View Change Button to change the sound.
- Press either the Test Button or the Start Button to return to the Menu mode.

8 - 8 C. R. T. TEST

Choose C. R. T. TEST to have the following screen for monitor adjustment appear.

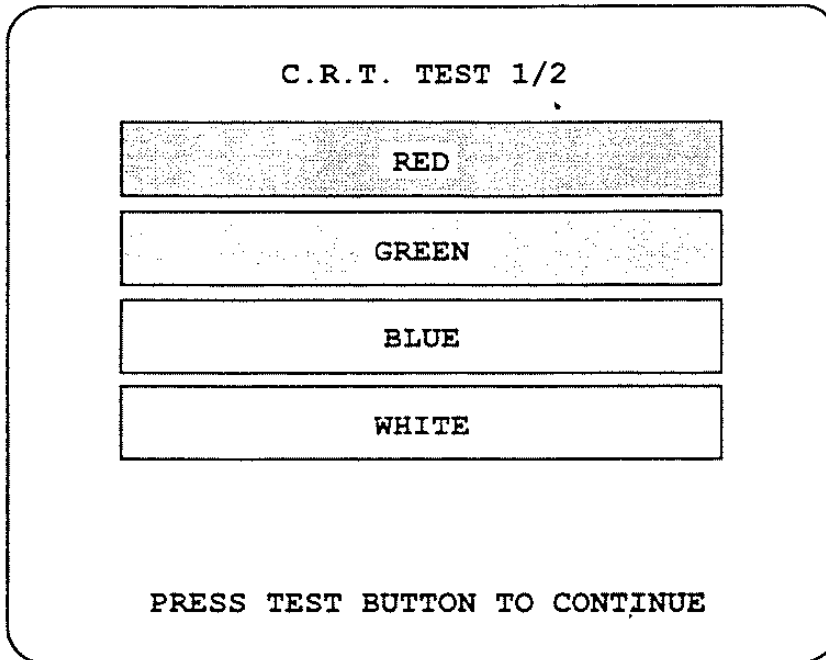

FIG. 8.8a C. R. T. TEST

The C.R.T. TEST as shown in FIG. 8.8a allows for monitor color checking. Each of the 4 colors, i. e., R (red), G (green), B (blue), and white is darkest at the left-hand end and becomes brighter towards the right-hand end.

In the FIG. 8.8b, adjust the monitor to make sure that the crosshatch lines do not go beyond the screen size and crosshatch distortion does not occur.

Press either the Test Button or the Start Button to have the following crosshatch screen appear.

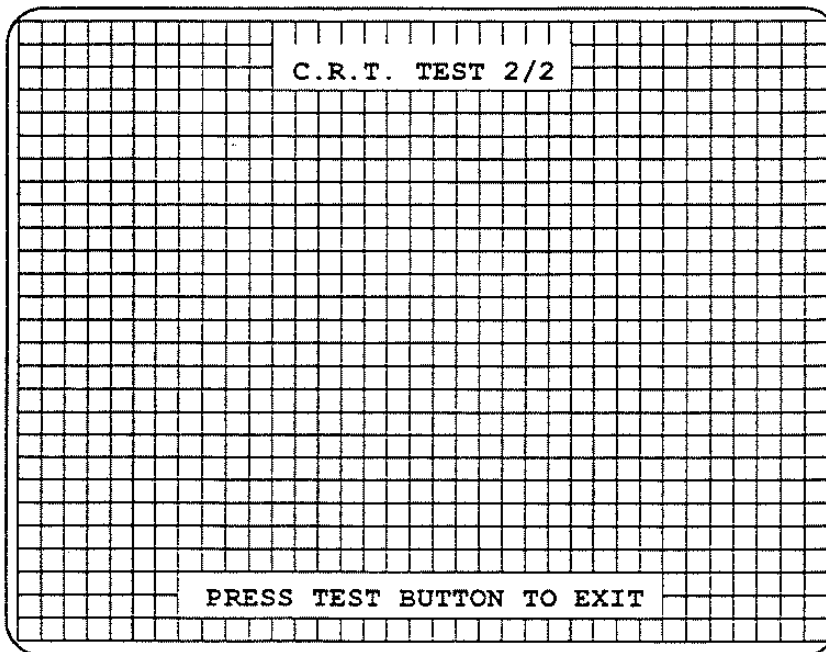

FIG. 8.8b C. R. T. TEST

Press either the Test Button or the Start Button to return to the Menu mode.

8 - 9 GAME ASSIGNMENTS

Selecting the GAME ASSIGNMENTS in the menu mode causes the present game setting to be displayed and also the game setting changes can be made. Each item displays the following content.

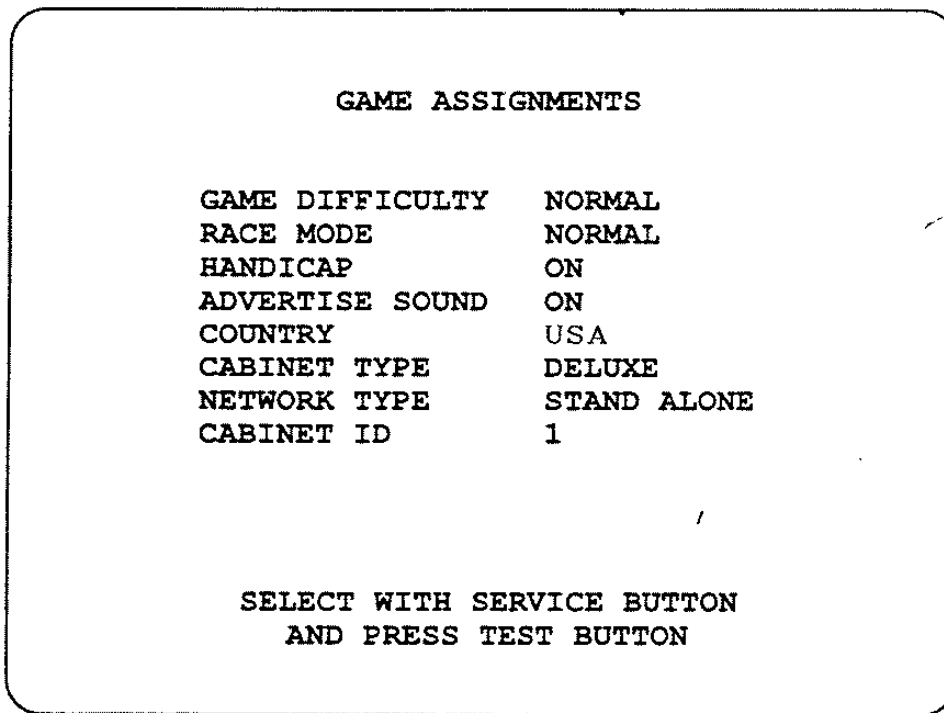

FIG. 8.9 GAME ASSIGNMENTS

- **GAME DIFFICULTY** The game difficulty can be varied by changing the time allowed at the time of race start and the additional time allowed when passing the checkpoints. Choose from among the following 5 categories. (Standard difficulty is NORMAL.)

1. VERY EASY
3. NORMAL
4. HARD
5. HARDEST

- **RACE MODE** The Race Mode has 2 types, NORMAL and LONG. Number of Laps can be changed. (Standard setting is NORMAL.)

	INDY 500	HIGHLAND	BAY SIDE
NORMAL	4 Laps	3 Laps	3 Laps
LONG	20 Laps	17 Laps	15 Laps

- **HANDICAP** Set to ON when using this setting to make correction for speeding up the cars whose position is No. 2 or lower in the vs. interactive competition. If not using this feature, set to OFF. (Normally, this is set to ON.)
- **ADVERTISE SOUND** Set this to ON to have sound produced during Demo mode and to OFF for not producing sound.
- **COUNTRY** Message Language (select USA for the U.S.A., and EXPORT for other countries.)
- **CABINET TYPE** Set to DELUXE.
- **NETWORK TYPE** There are 3 types, i. e., STAND ALONE, MASTER and SLAVE. Choose STAND ALONE for a single player. For interactive play, choose MASTER for one unit and SLAVE for the remaining units.
- **CABINET ID** When cabinets are linked for interactive play, use the ID number sequentially in order starting from the leftmost cabinet. Otherwise, on-screen display in the ADVERTISE mode will not be consistent in continuity between units.

For Communication play, refer to 19. COMMUNICATION PLAY.

SETTING CHANGE PROCEDURE

- Press the SERVICE button or VIEW CHANGE button to move the arrow (->) to the desired setting change item.
- Press the TEST button or START button to make a setting change selection.
- Move the arrow to EXIT and press TEST button or START button to return to the MENU mode.

8 - 10 COIN ASSIGNMENT

The "COIN ASSIGNMENTS" mode permits you to set the start number of credits, as well as the basic numbers of coins and credits. This mode expresses "how many coins correspond to how many credits."

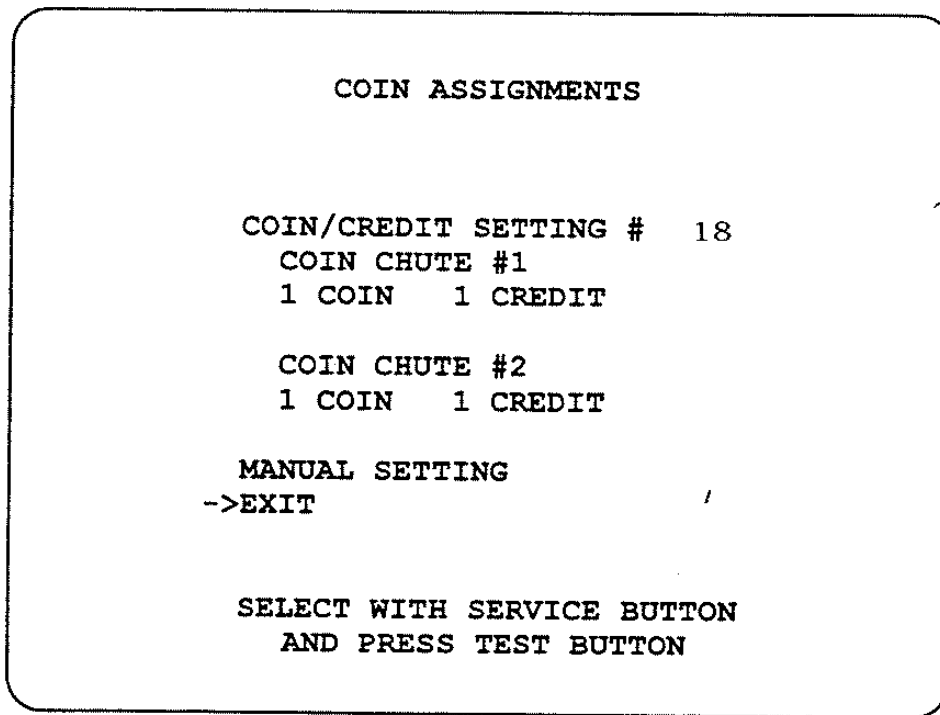

FIG. 8.10 a COIN ASSIGNMENTS

- COIN/CREDIT SETTING "How many coins correspond to how many credits."
In this machine, selection as per Table 8.10a is possible.
- MANUAL SETTING Allows for finer settings. (Table 8.10b)

SETTING CHANGE PROCEDURE

- ① Press the SERVICE button or VIEW CHANGE button to move the arrow (->) to the desired setting change item.
- ② Press the TEST button or START button to make a setting change selection.
- ③ Move the arrow to EXIT and press TEST button or START button to return to the MENU mode.

TABLE 8.10 a COIN/CREDIT SETTING

NAME OF SETTING	FUNCTIONING OF COIN CHUTE #1		FUNCTIONING OF COIN CHUTE #2	
SETTING #1	1 COIN	1 CREDIT	1 COIN	1 CREDIT
SETTING #2	1 COIN	2 CREDITS	1 COIN	1 CREDIT
SETTING #3	1 COIN	3 CREDITS	1 COIN	1 CREDIT
SETTING #4	1 COIN	4 CREDIT S	1 COIN	1 CREDIT
SETTING #5	1 COIN	5 CREDITS	1 COIN	1 CREDIT
SETTING #6	1 COIN	2 CREDITS	1 COIN	2 CREDITS
SETTING #7	1 COIN	5 CREDITS	1 COIN	2 CREDITS
SETTING #8	1 COIN	3 CREDITS	1 COIN	3 CREDITS
SETTING #9	1 COIN	4 CREDITS	1 COIN	4 CREDITS
SETTING #10	1 COIN	5 CREDITS	1 COIN	5 CREDITS
SETTING #11	1 COIN	6 CREDITS	1 COIN	6 CREDITS
SETTING #12	2 COINS	1 CREDIT	2 COINS	1 CREDIT
SETTING #13	1 COIN	1 CREDIT	2 COINS	1 CREDIT
SETTING #14	1 COIN	2 CREDITS	2 COINS	1 CREDIT
SETTING #15	1 COIN	1 CREDIT	1 COIN	1 CREDIT
	2 COINS	3 CREDITS	2 COINS	3 CREDITS
SETTING #16	1 COIN	3 CREDIT S	1 COIN	1 CREDITS
			2 COINS	3 CREDITS
SETTING #17	3 COINS	1 CREDIT	3 COINS	1 CREDIT
SETTING #18	4 COINS	1 CREDIT	4 COINS	1 CREDIT
SETTING #19	1 COIN	1 CREDIT	1 COIN	1 CREDIT
	2 COINS	2 CREDITS	2 COINS	2 CREDITS
	3 COINS	3 CREDITS	3 COINS	3 CREDITS
	4 COINS	5 CREDITS	4 COINS	5 CREDITS
SETTING #20	1 COIN	5 CREDITS	1 COIN	1 CREDIT
			2 COINS	2 CREDITS
			3 COINS	3 CREDITS
			4 COINS	5 CREDITS
SETTING #21	5 COINS	1 CREDIT	5 COINS	1 CREDIT
SETTING #22	1 COIN	2 CREDITS	3 COINS	1 CREDIT
			5 COINS	2 CREDITS
SETTING #23	2 COINS	1 CREDIT	2 COINS	1 CREDIT
	4 COINS	2 CREDITS	4 COINS	2 CREDITS
	5 COINS	3 CREDITS	5 COINS	3 CREDITS
SETTING #24	1 COIN	3 CREDIT	2 COINS	1 CREDIT
			4 COINS	2 CREDITS
			5 COINS	3 CREDITS
SETTING #25	1 COIN	1 CREDIT	1 COIN	1 CREDIT
	2 COINS	2 CREDITS	2 COINS	2 CREDITS
	3 COINS	3 CREDITS	3 COINS	3 CREDITS
	4 COINS	4 CREDITS	4 COINS	4 CREDITS
	5 COINS	6 CREDITS	5 COINS	6 CREDITS
SETTING #26	1 COIN	1 CREDIT	1 COIN	1 CREDIT
			2 COINS	2 CREDITS
			3 COINS	3 CREDITS
			4 COINS	4 CREDITS
			5 COINS	6 CREDITS
SETTING #27	FREE PLAY		FREE PLAY	

MANUAL SETTING

```
MANUAL SETTING

COIN TO CREDIT  1 COIN  1CREDIT
BONUS ADDER     NO BONUS ADDER

COIN CHUTE #1   MULTIPLIER
1 COIN COUNTS AS 1 COIN
COIN CHUTE #2   MULTIPLIER
1 COIN COUNTS AS 1 COIN

->EXIT

SELECT WITH SERVICE BUTTON
AND PRESS TEST BUTTON /
```

FIG. 8.10 b COIN ASSIGNMENTS

- COIN TO CREDIT Determines conversion coins/credit.
- BONUS ADDER This sets how many conversion coins should be inserted to obtain one Service Coin.
- COIN CHUTE #X MULTIPLIER This sets how many inserted tokens one conversion coin represents.

TABLE 8.10b MANUAL SETTING

COIN TO CREDIT	1 COIN	1 CREDIT
	2 COINS	1 CREDIT
	3 COINS	1 CREDIT
	4 COINS	1 CREDIT
	5 COINS	1 CREDIT
	6 COINS	1 CREDIT
	7 COINS	1 CREDIT
	8 COINS	1 CREDIT
	9 COINS	1 CREDIT

BONUS ADDER	NO BONUS ADDER
	2 COINS GIVE 1 EXTRA COIN
	3 COINS GIVE 1 EXTRA COIN
	4 COINS GIVE 1 EXTRA COIN
	5 COINS GIVE 1 EXTRA COIN
	6 COINS GIVE 1 EXTRA COIN
	7 COINS GIVE 1 EXTRA COIN
	8 COINS GIVE 1 EXTRA COIN
	9 COINS GIVE 1 EXTRA COIN

COIN CHUTE MULTIPLIER	1 COIN COUNTS AS 1 COIN
	1 COIN COUNTS AS 2 COINS
	1 COIN COUNTS AS 3 COINS
	1 COIN COUNTS AS 4 COINS
	1 COIN COUNTS AS 5 COINS
	1 COIN COUNTS AS 6 COINS
	1 COIN COUNTS AS 7 COINS
	1 COIN COUNTS AS 8 COINS
	1 COIN COUNTS AS 9 COINS

8 - 11 VOLUME SETTING

This setting mode allows V.R. value for each of Steering Wheel and Pedal to be set.

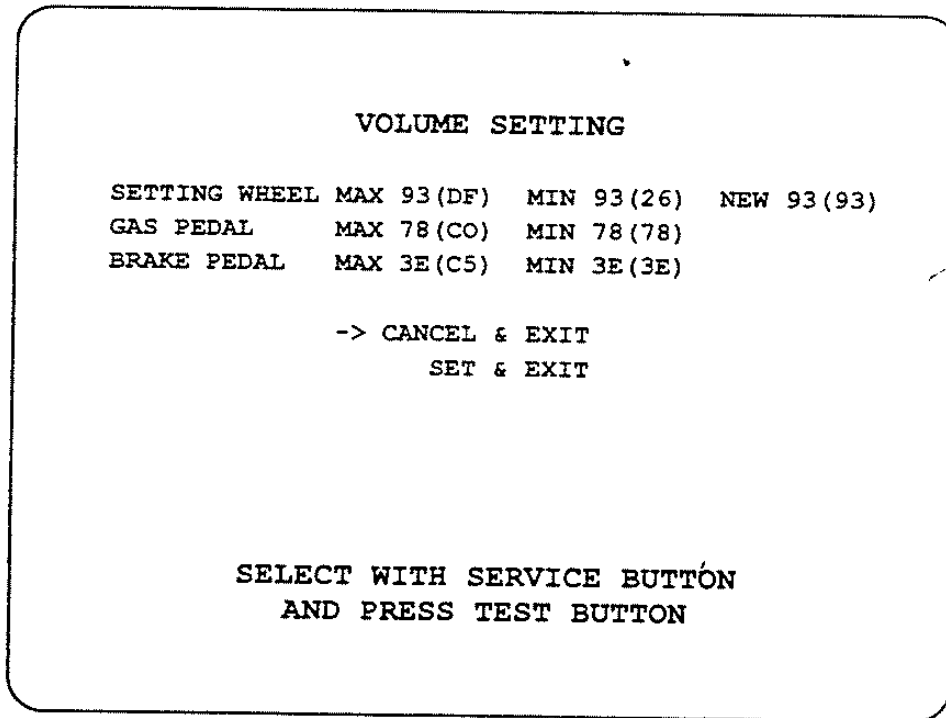

FIG. 8. 11 VOLUME SETTING

V. R. VALUE SETTING PROCEDURE

- ① Step on the GAS PEDAL fully and then release it.
- ② Step on the BRAKE PEDAL fully and then release it.
- ③ Turn the Steering Wheel fully to the left & right, and maintain the centering position by referring to the level line shown.
- ④ Press either the Service Button or the View Change Button to bring the arrow (->) to SET & EXIT.
- ⑤ While maintaining the Steering Wheel's centering position, press either the Test Button or Start Button to set V.R. value set, returning to the Menu mode.

Bringing the arrow to CANCEL & EXIT and Pressing either the Test Button or Start Button causes the Menu mode to return on the screen without setting the V. R. value.

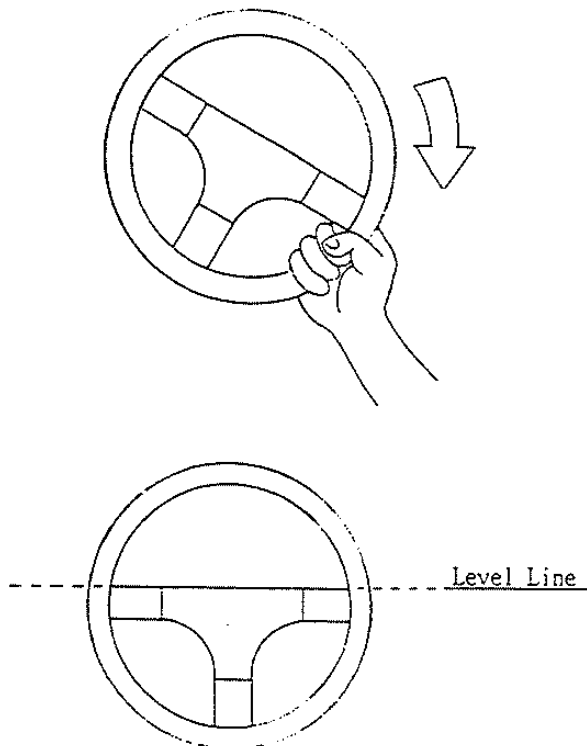

FIG. 8. 11

8 - 12 BOOKKEEPING

Selecting the BOOKKEEPING in the menu mode displays the bookkeeping data up to the present on the following 2 pages.

Press the TEST button again to proceed to the next page.

BOOKKEEPING 1/2	
COIN CHUTE #1	0
COIN CHUTE #2	0
TOTAL COINS	0
COIN CREDITS	0
SERVICE CREDITS	0
TOTAL CREDITS	0
NUMBER OF GAMES	0
TOTAL TIME	0D 0H 0M 0S
PLAY TIME	0D 0H 0M 0S
AVERAGE PLAY TIME	0H 0M 0S
LONGEST PLAY TIME	0H 0M 0S
SHORTEST PLAY TIME	0H 0M 0S

PRESS TEST BUTTON TO CONTINUE

FIG. 8. 12 a BOOKKEEPING (1/2)

BOOKKEEPING 2/2	
TIME HISTOGRAM	
0M00S~0M29S	0
0M30S~0M59S	0
1M00S~1M29S	0
1M30S~1M59S	0
2M00S~2M29S	0
2M30S~2M59S	0
3M00S~3M29S	0
3M30S~3M59S	0
4M00S~4M29S	0
4M30S~4M59S	0
OVER 5M00S	0

PRESS TEST BUTTON TO EXIT

FIG. 8. 12 b BOOKKEEPING (2/2)

- COIN CHUTE#* Number of coins put in. As seen from the front of the cabinet, the right-hand side is #1 and the left-hand side is #2.
- TOTAL COINS Total number of coins inserted in each coin chute.
- COIN CREDITS Number of credits registered by inserting coins
- SERVICE CREDITS Credits registered by the SERVICE button
- TOTAL CREDITS Total number of credits (COIN CREDITS + SERVICE CREDITS)
- TOTAL TIME The total energized time.
- TIME HISTOGRAM By-playtime play frequency.

8 - 13 BACKUP DATA CLEAR

Clears the contents of BOOKKEEPING. When clearing, use the Service Button or View Change Button to bring the arrow (->) to "YES (CLEAR)" and press either the Test Button or the Start Button. When the data has been cleared, "COMPLETED" will be displayed. Press the Test Button or the Start Button to return to the Menu mode.

Bring the arrow to "NO (CANCEL)" and press either the Test Button or Start Button to return to the Menu mode without clearing the data.

Also, note that the game setting contents are not affected by BACKUP DATA CLEAR operation.

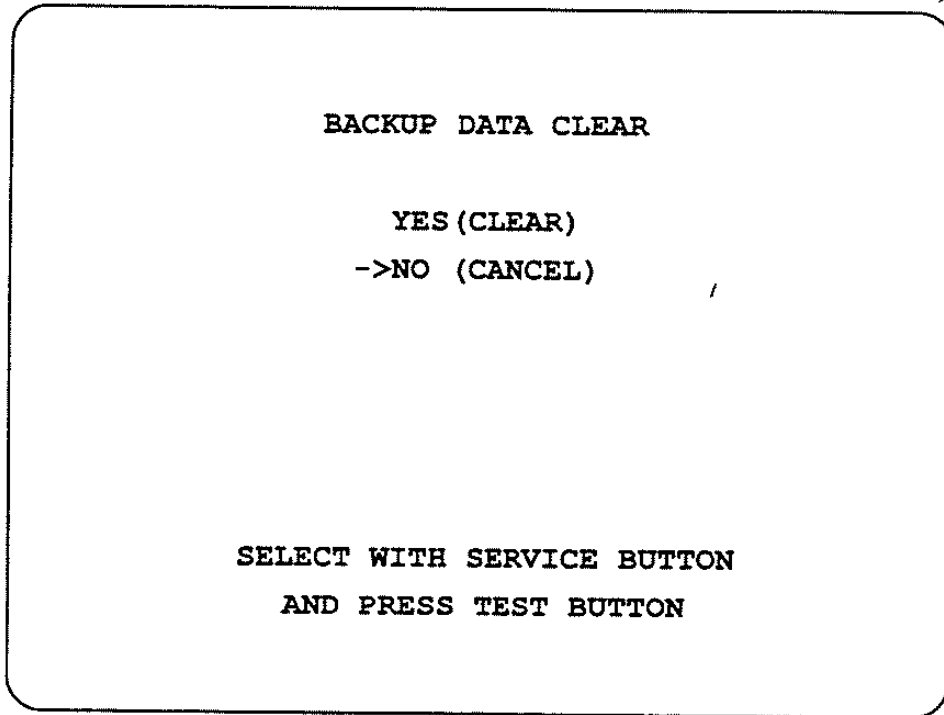

FIG. 8.13 BACKUP DATA CLEAR

9. CONTROL PANEL



- This unit is a heavy item weighing approximately 21kg. and therefore, be very careful when performing the work.
- Immediately after the game is finished, the motor may still be very hot. When performing the removal work, wait until the motor cools off.

On the Test mode, if the Steering Wheel's V. R. variations are not within the allowable range, the V. R. installation position adjustments or V. R. replacement are needed. Also, be sure to apply greasing to the V.R. Gear portion once every 3 months.

9 - 1 REMOVING THE CONTROL PANEL

- ① Remove a total of 6 Tamperproof Screws from the upper and lower parts of the Control Panel. At this time, be sure to firmly hold the Control Panel so as not to drop it.
- ② Carefully draw the Control Panel from the Front Cabinet. At this time, pulling out the Control Panel completely may cause wiring breakage, therefore, be sure to draw it half-way and not completely.
- ③ Disconnect all of the Connectors connected to the Front Cabinet.
- ④ Pull out the Control Panel completely. When putting it down, be very careful so as not to damage the V. R. portion of the motor's rear end.

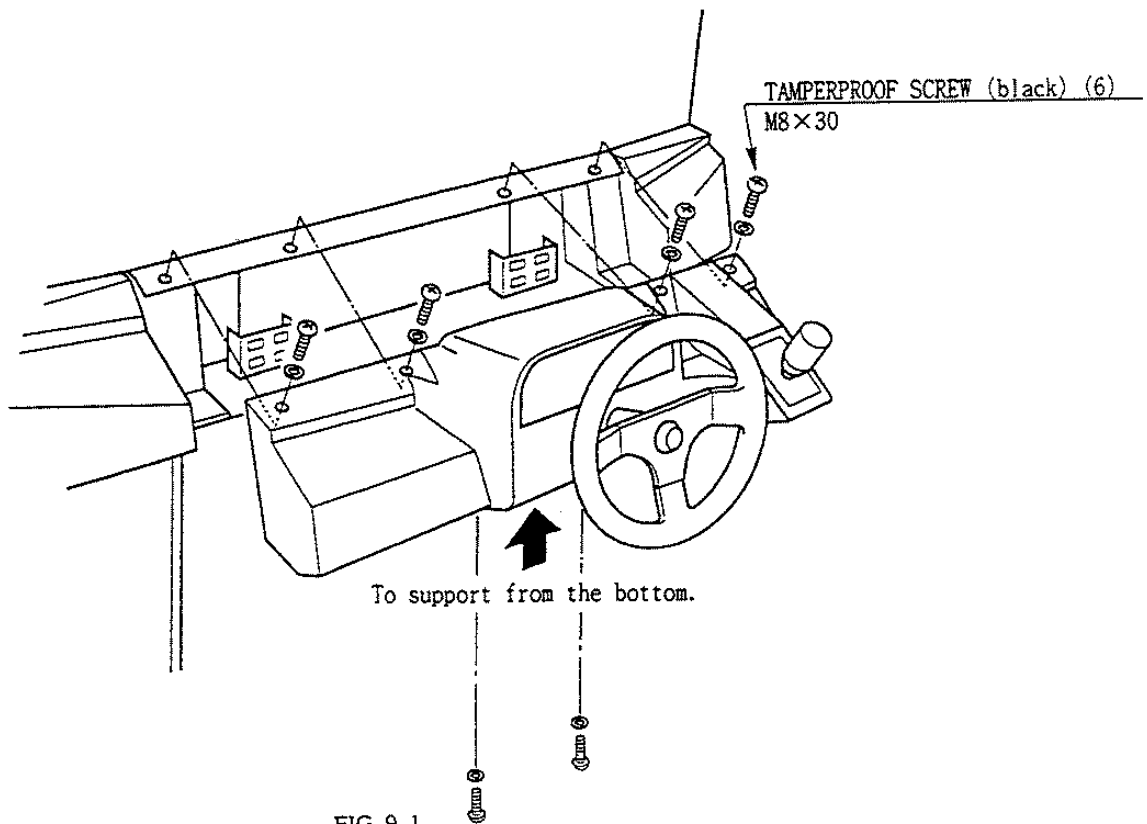

9 - 2 ADJUSTING AND REPLACING THE V. R.

The V. R. on the right-hand side of the Steering Wheel Mechanism is for the Game BD & Drive Control, and the V. R. on the left-hand side is for the Motor Control BD. Check V. R. values in the Test mode. The appropriate values of each V.R. are as follows:

	Left	Centering position	Right
For Game BD & Drive Control:	2DH or lower ←	7DH~83H	→ D3H or higher
For Motor Control:	2DH or lower ←	7DH~83H	→ D3H or higher

REPLACING THE V. R.

After disconnecting the V. R. to be replaced, take off the 2 screws which secure the V.R. Bracket by using the Spanner, and then remove the V.R. with the gear as is attached. After replacement, check V.R. value variations in the Test mode.

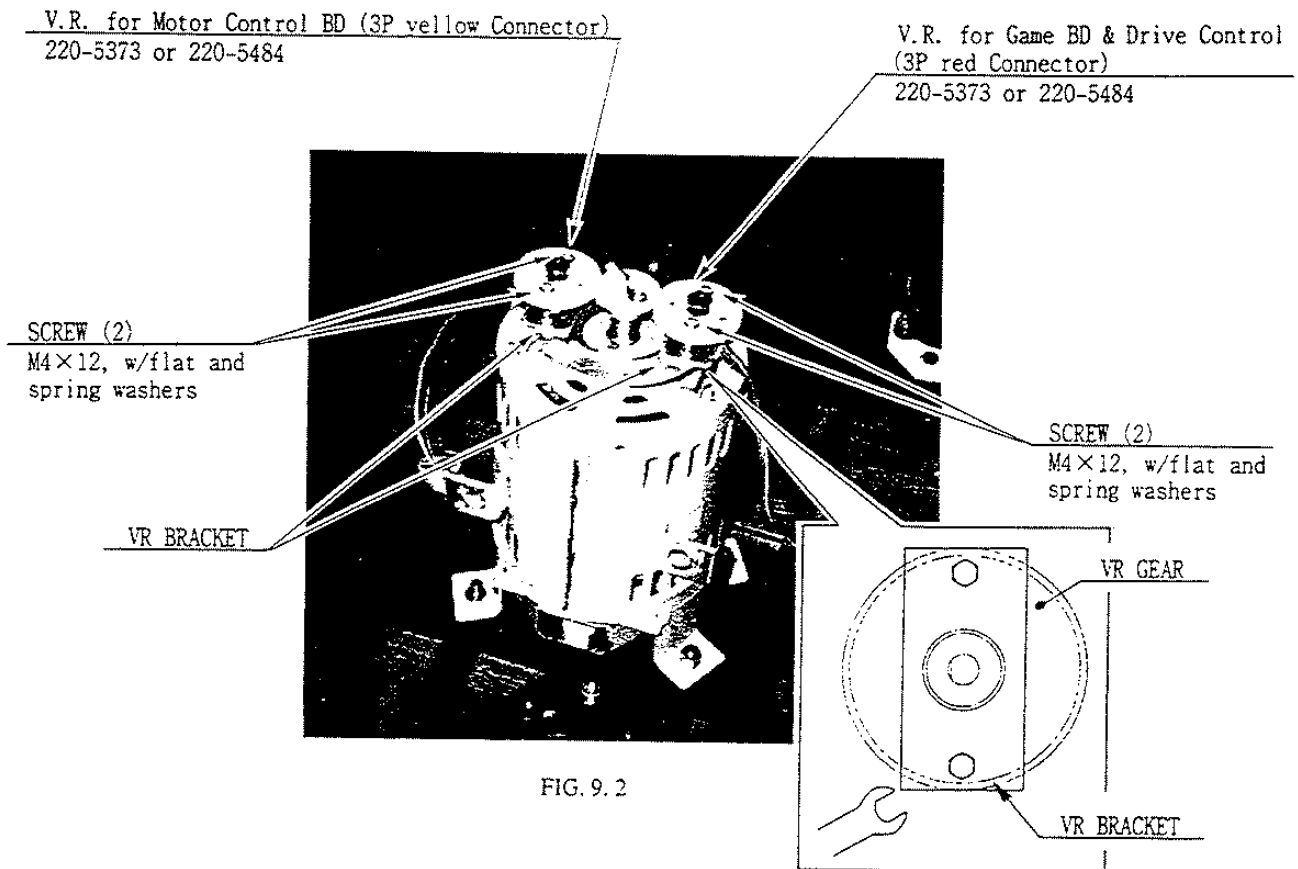

FIG. 9.2

ADJUSTING THE V. R.

- ① By using the Spanner, loosen the 2 screws which secure the V.R. Bracket, move the V.R. Bracket and disengage the gear mesh.
- ② Ensure that the V. R. value is within the range of the centering position.
- ③ Mesh the gears to secure the V. R. Bracket. At this time, ensure that an appropriate backlash is obtained.
- ④ When the Steering Wheel is in the centering position, if the V.R. value is not appropriate, make fine adjustments by loosening the 2 screws which secure the V. R. gear, turning the gear holder and making sure that the V.R. value is appropriate.
- ⑤ Turn the Steering Wheel to check V. R. value variations.

9 - 3 GREASING

Apply greasing to gear portions once every 3 months.

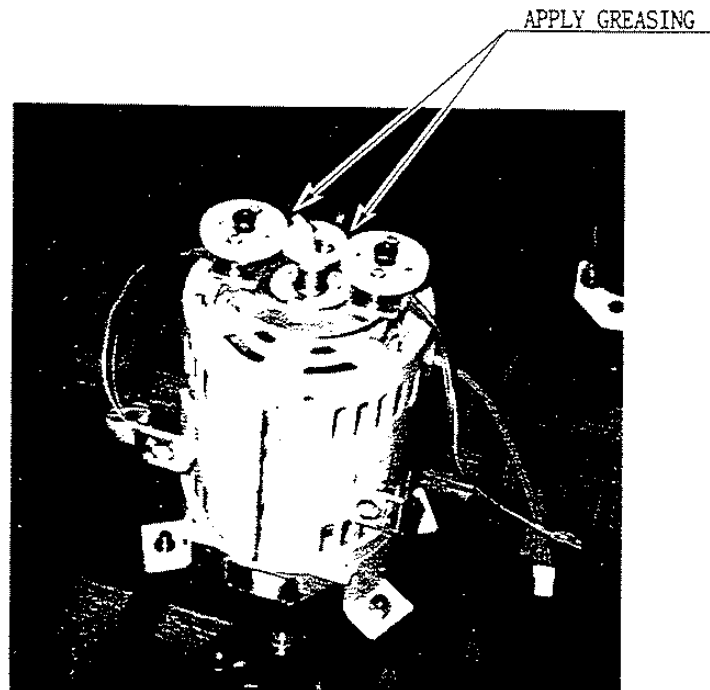

FIG. 9.3

10. SHIFT LEVER

In the Test mode, if the SHIFT LEVER's SW can not be inputted satisfactorily, replace the Switch. Apply greasing to the Mechanism's sliding portion once every 3 months. When performing the above work, remove the Shift Lever Unit.

10 - 1 REMOVING THE SHIFT LEVER

- ① Remove the 4 Tamperproof Screws to lift the Shift Lever Unit.
- ② Disconnect the Connector to remove the Shift Lever Unit.
- ③ When reinstalling, follow the procedure opposite as when removing. At this time, ensure that "DOWN" display appears on the upper part as shown.

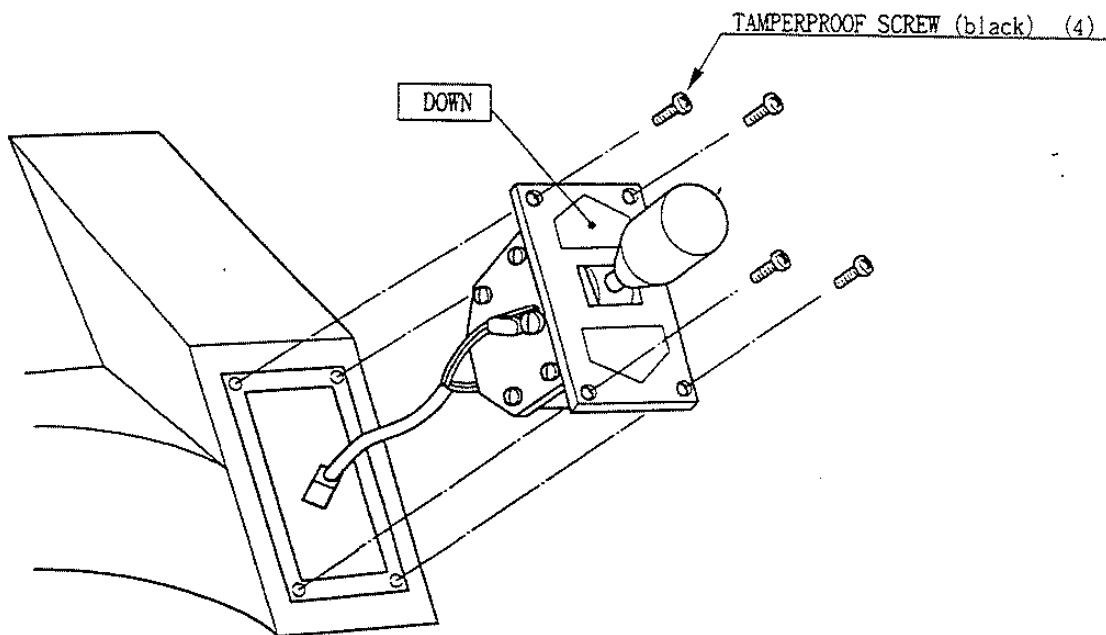

FIG. 10. 1

10 - 2 SWITCH REPLACEMENT

Method of replacement

- ① Disconnect the wiring Connector of the Switch to be replaced.
- ② Remove the 2 Tapping Screws (M3×16) to replace the Microswitch.

10 - 3 GREASING

Apply greasing once in 3 months to the specified portions.

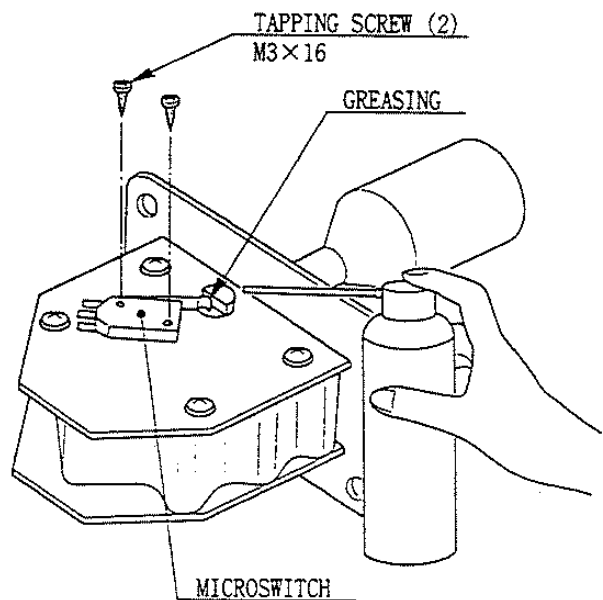
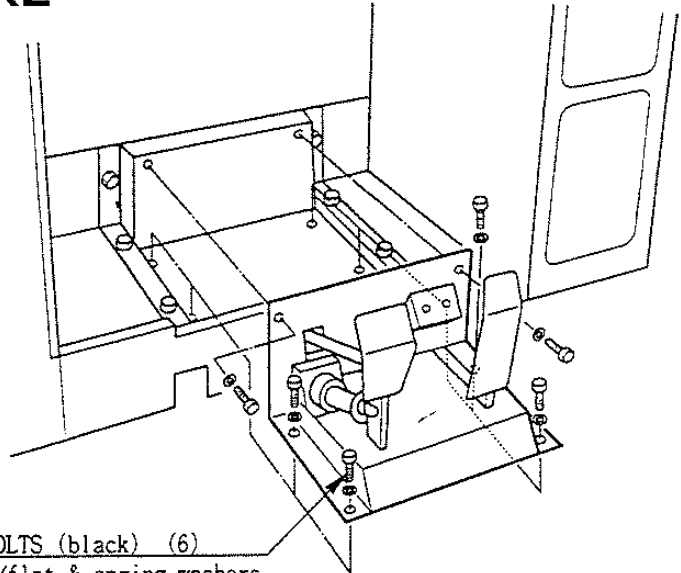

FIG. 10. 2

11. ACCELERATOR & BRAKE

In the test mode, if the ACCEL. & BRAKE V.R. value is not within the allowable range, an adjustment of V.R. installation position, or a replacement of V. R. is needed. Also, grease the Mechanism's shafts and sliding portions once every 3 months.

When performing the above work, remove the 6 Hexagon Bolts and carefully draw the Unit (the weight of which is approximately 6kg.) in the manner not to damage the wiring.



HEXAGON BOLTS (black) (6)
M8×30, w/flat & spring washers

FIG. 11

11 - 1 ADJUSTING AND REPLACING THE V.R.

Pull out the Unit, and ACCEL. & BRAKE Mechanism/ appears. The V. R. on the left-hand side of the Mechanism is for the ACCEL., and the V. R. on the right-hand side of the Mechanism is for the BRAKE. Check the V. R. values in the test mode. The appropriate value of each V.R. is as follows:

	When released:		When stepped on:
ACCEL. :	Under 30 H	↔	Over C0H
BRAKE :	Under 30 H	↔	Over C0H

Method of V. R. replacement

To replace the V. R., after taking off the connector from the V. R. to be replaced, take out the 2 screws which secure the V. R. Bracket, and remove the V. R. together with the bracket and gear. After the replacement, check the V. R. value variations in the test mode.

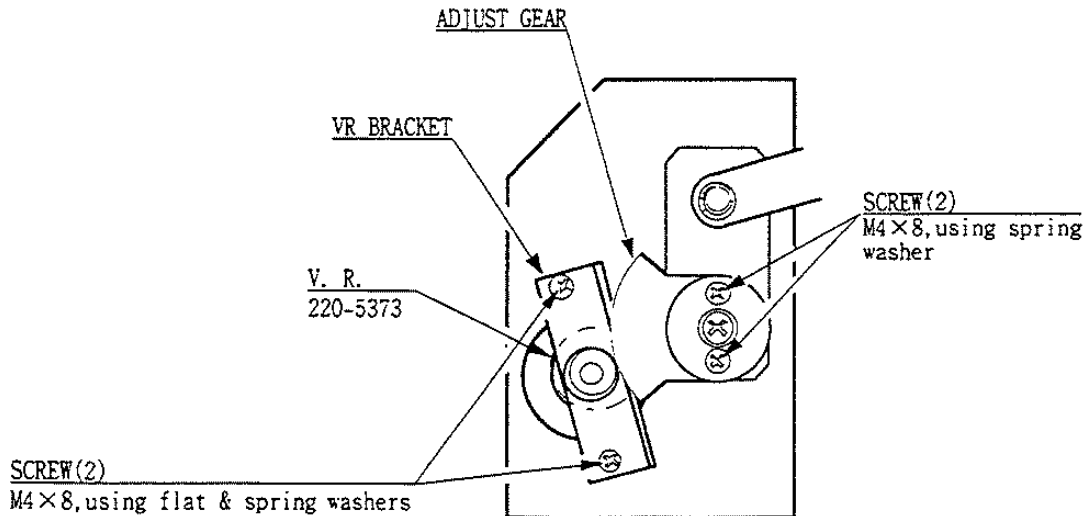

FIG. 11.1

Method of V. R. adjustment

- ① Loosen the 2 screws which secure the V. R. Bracket and move the V. R. Bracket to disengage the gears.
- ② Have the V. R. value match with the value obtained when the pedal is released.
- ③ Mesh the gears to secure the V. R. Bracket. At this time, be sure to obtain an appropriate backlash.
- ④ Step on the pedal and check V. R. value variations. If the value is not within the above appropriate range, loosen the 2 screws which secure the ADJUST GEAR to make an adjustment.

11 - 2 GREASING

Apply greasing to the gear and shaft portions once every 3 months.

Apply greasing in the following procedure:

- ① Remove the 4 Tamperproof Screws (black) which secure the Pedal Cover and remove the Pedal Cover by moving it forward.
- ② Remove the Pedal Shaft from the lower portions of ACCEL. pedal and BRAKE pedal. At this time, ensure that the ACCEL pedal and BRAKE pedal are firmly secured as they are subjected to torsion spring force.
- ③ After applying greasing to each part, assemble in the procedure opposite as when disassembling.

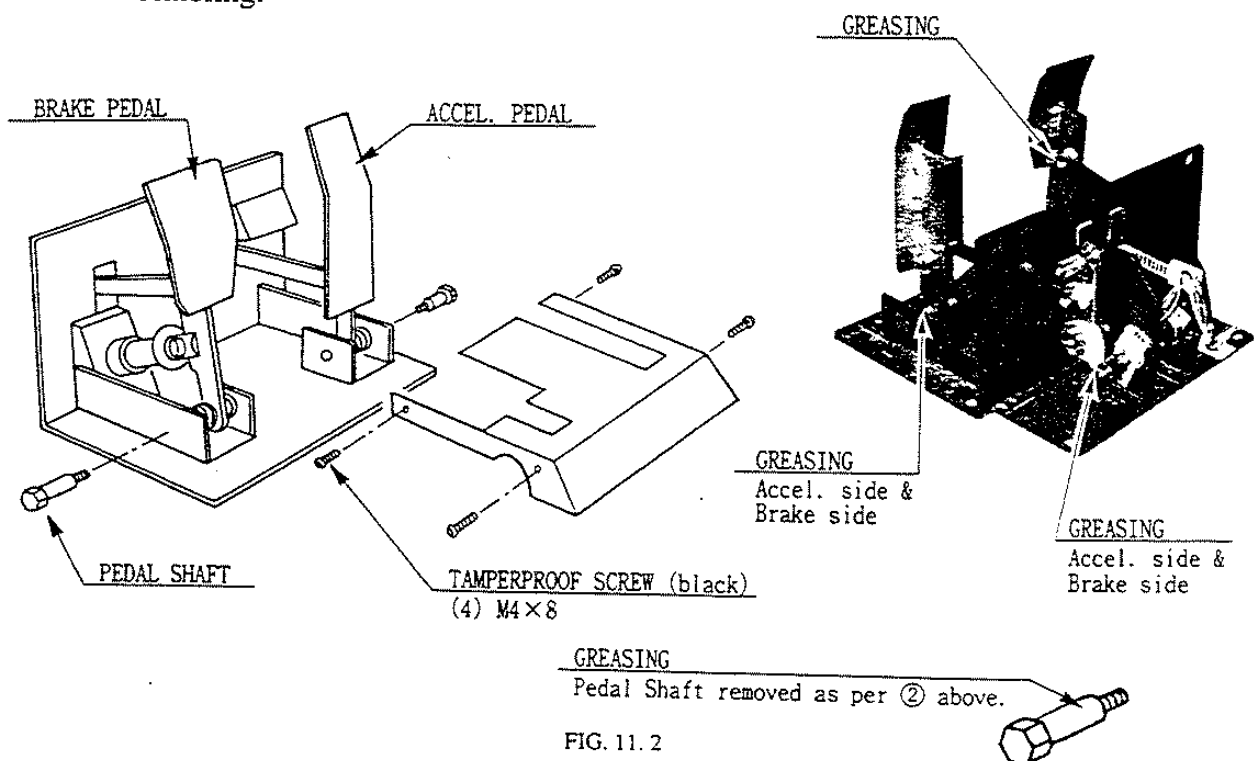

FIG. 11.2

12. COIN SELECTOR

HANDLING THE COIN JAM

If the coin is not rejected even when the REJECT button is pressed, open the coin chute door and open the selector gate. After removing the jammed coin, put a normal coin in and check to see that the selector correctly functions.

CLEANING THE COIN SELECTOR

The coin selector should be cleaned once every 3 months. When cleaning, follow the procedure below:

- ① Turn the power for the machine OFF. Open the coin chute door.
- ② Open the gate and dust off by using a soft brush (made of wool, etc.).
- ③ Remove stain by wiping with a soft cloth which contains water or chemical detergent.

- ④ Remove the CRADLE.

When removing the retaining ring (E ring), be very careful so as not to bend the shaft.

- ⑤ Remove stain from the shaft and pillow portions by wiping off with a soft cloth, etc.
- ⑥ After wiping off as per 5 above, further apply a dry cloth, etc. to cause the coin selector to dry completely.



IMPORTANT!

- Never apply machine oil, etc. to the Coin Selector.
- After cleaning the Coin Selector, insert a regular coin in the normal working status and ensure that the Selector correctly functions.

COIN INSERTION TEST

Once every month, when performing the Coin SW Test, simultaneously check the following:

- Does the Coin Meter count satisfactorily?
- Does the coin drop into the Cashbox correctly?
- Is the coin rejected when inserted while keeping the Reject Button pressed down?

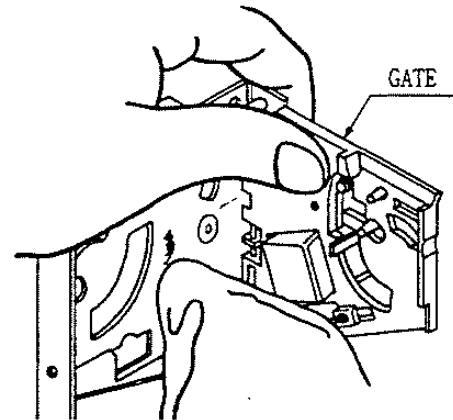

FIG. 12 a

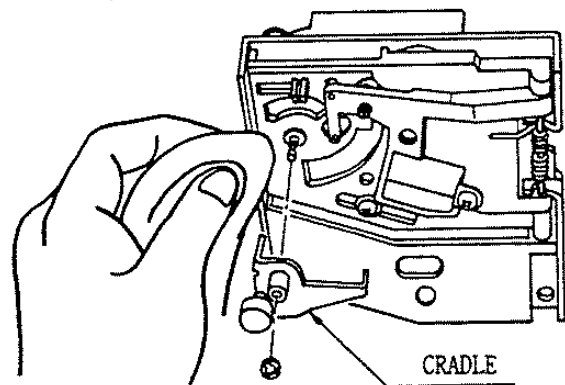
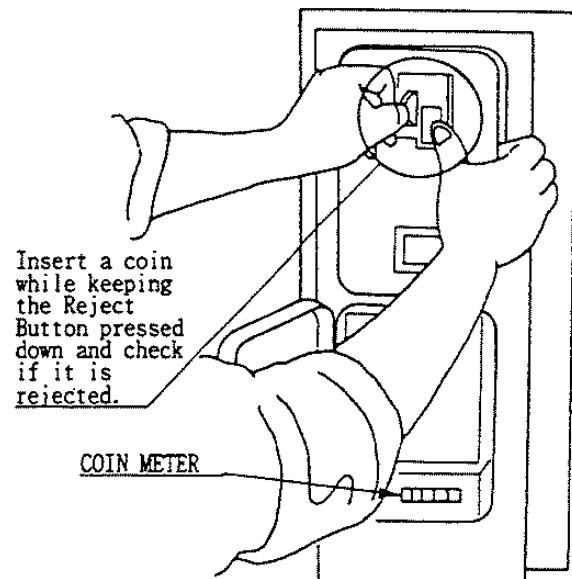

FIG. 12 b



Insert a coin while keeping the Reject Button pressed down and check if it is rejected.

FIG. 12 c

13. PROJECTOR



- Since the Projector screen can be easily damaged, handle with care!. When cleaning, do not use water or volatile chemicals.
- Since the Projector has been adjusted at the time of shipment, avoid making further adjustments without good reason.

13 - 1 REMOVING THE MONITOR MASK



The Monitor Mask is of a very large size and has glass portions. Be sure to perform the work by plural persons.

- ① Take out the 2 Truss Screws and open the Roof Lid attached to the Billboard by using the Master Key.

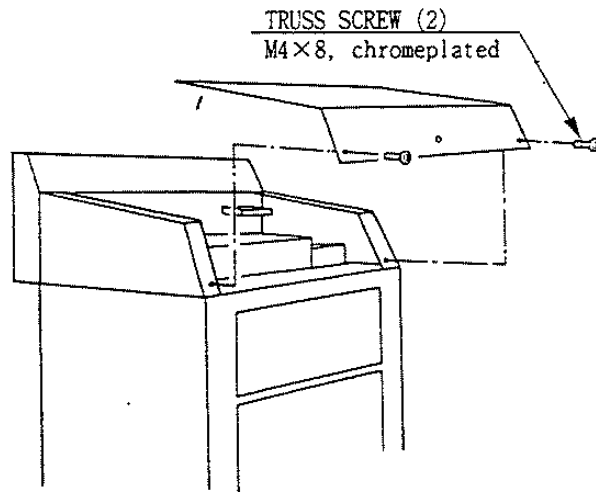

FIG. 13. 1 a

- ② Lift the Billboard Case (the weight of which is approximately 8 kg.) and carefully remove it by moving it towards you. At this time, pay attention to the Fluorescent Lamp which is on the Front Cabinet side.

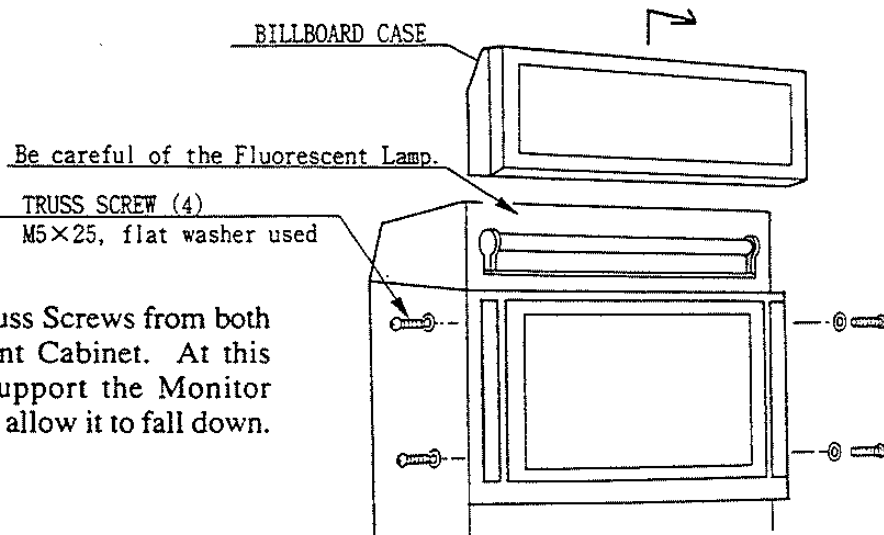

FIG. 13. 1 b

- ③ Remove the 4 Truss Screws from both sides of the Front Cabinet. At this time, slightly support the Monitor Mask so as not to allow it to fall down.

- ④ Slightly lift the Monitor Mask and carefully remove it forward. At this time, pay careful attention to the Fluorescent Lamp above.

Be careful of the Fluorescent Lamp.

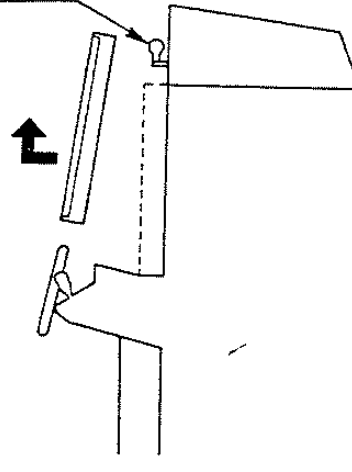

FIG. 13. 1 c

- ⑤ When reinstalling, use the procedure opposite as when removing. Be very careful of the Fluorescent Lamp.

13 - 2 CLEANING THE MONITOR MASK

When cleaning the Monitor Mask, follow the instructions below so as not to damage the Front Glass.



- Use alcohol based cleaner (liquid) agent.
- Use soft cloth.
- When removing adhered extraneous matter such as large particles (dust), etc., do not rub them with cloth.

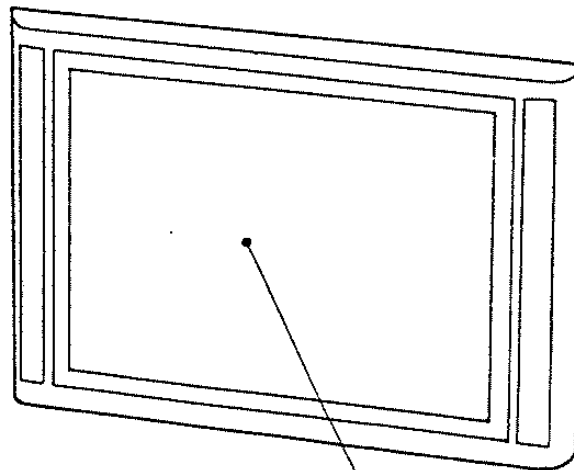

Clean the face and the rear.

FIG. 13. 2

13 - 3 CLEANING THE SCREEN

When the screen surface becomes dirty with dust, etc., clean it by using a soft cloth such as gauze. Water, and volatile chemicals such as benzene, thinner, etc., will damage the screen surface, and should not be used. Also, since the surfaces can be easily damaged, avoid rubbing them with any abrasive materials or using a duster.

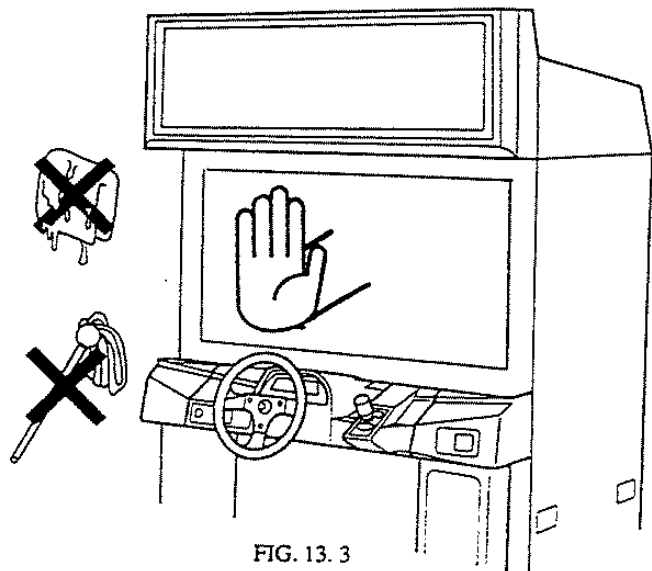

FIG. 13. 3

13 - 4 ADJUSTING THE PROJECTOR



CAUTION!

Never touch places other than those specified. Otherwise, hazardous electric shock or short-circuit can be caused.

Take out the 6 Truss Screws from Front Panel L of the front portion of the Front Cabinet, and the Projector's Control Panel appears.

□ PROJECTOR CONTROL PANEL

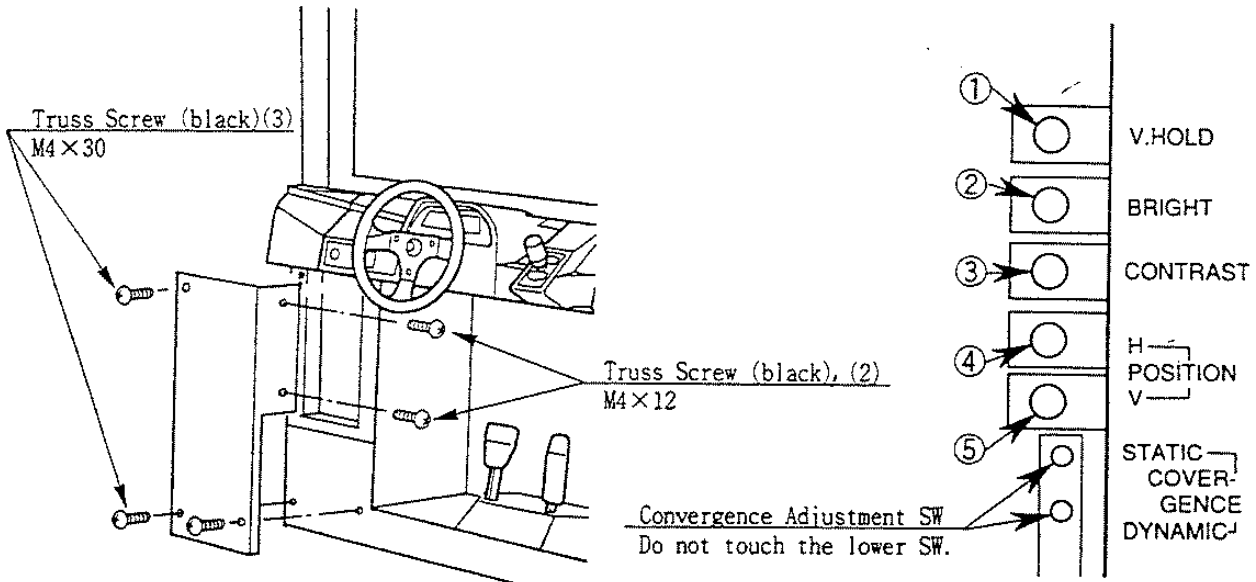

FIG. 13.4

- | | | |
|---------------|---------------|------------|
| ① V.HOLD | ② BRIGHT | ③ CONTRAST |
| ④ H. POSITION | ⑤ V. POSITION | |

STATIC CONVERGENCE ADJUSTMENT



CAUTION!

Do not touch the Dynamic Convergence Adjustment SW. Dynamic Convergence adjustment work is quite troublesome and the visual effect is expected to be negligible. As such, no explanation is given in this manual. Should the SW be pressed by mistake or otherwise, turn the power off and turn it back on again.

CROSS PATTERN

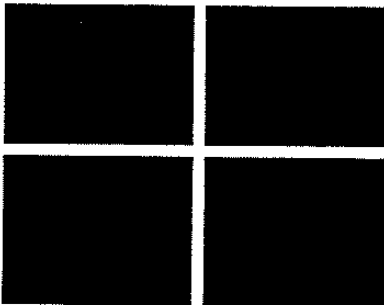

- ① Press the Static Convergence Adjustment SW which is on the Control Panel to cause the cross pattern to appear.
- ② Use the remote control to make static adjustment. For the operation of the Remote Controller, refer to the following pages.
- ③ Press the Static Convergence SW. At this time, static adjustment results are written and the PTV screen will return to the original screen mode.

The Remote Controller has 2 different types. Depending on the specific type, the adjustment procedure varies.

In the case of Remote Controller (Part No. 220-5297):

REMOTE CONTROL

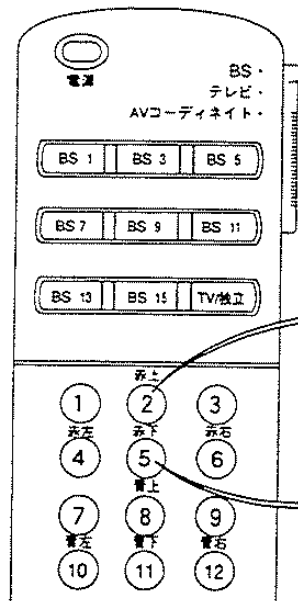

If the Convergence adjustment is incorrect, a red or blue line may appear to move when a Remote Control Numeral Key is pressed after the cross pattern appears. If the line is superimposed on the green cross pattern, the cross pattern becomes white.

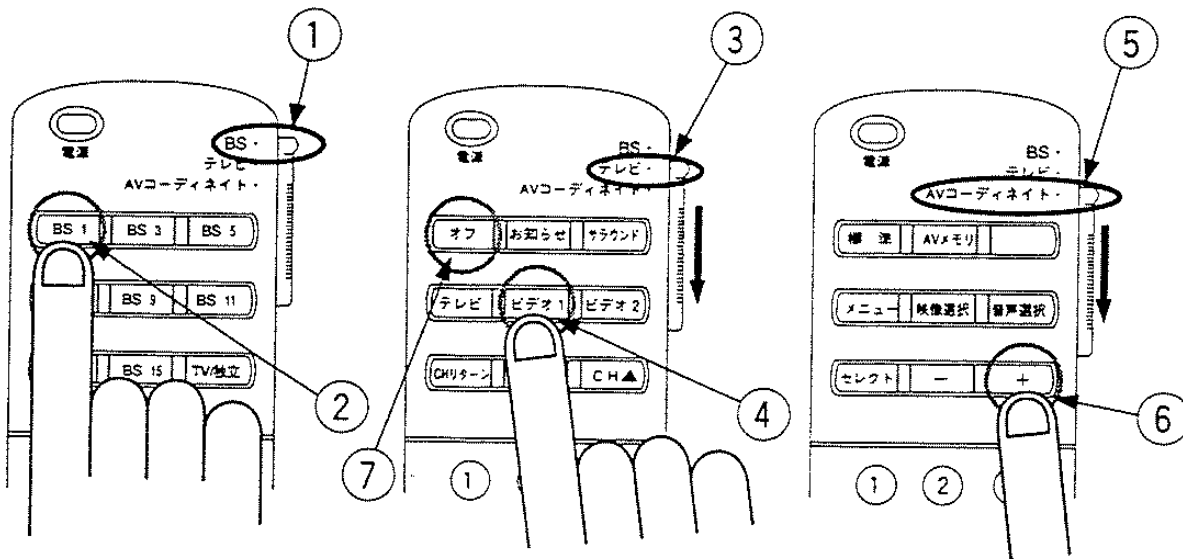
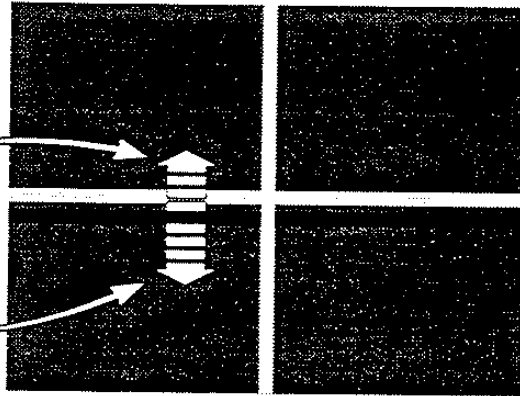

- ① Make sure that the slide portion of the Remote Control is positioned as per ① above.
- ② Press BS1.
- ③ Position the slide portion of the Remote Control to ③ in the above Figure.
- ④ Press VIDEO 1.
- ⑤ Position the Remote Control's slide portion to the above ⑤.
- ⑥ Press " + " to have the cross pattern appear.
- ⑦ Use the remote cotroller to make static adjustment.

Remote control [2], [5].....Causes the red horizontal line to match with the green horizontal line.

Remote control [4], [6].....Causes the red vertical line to match with the green vertical line.

Remote control [8], [11].....Causes the blue horizontal line to match with the green horizontal line.

Remote control [10], [12].....Causes the blue vertical line to match with the green vertical line.

- ⑧ Position the Remote Control's slide portion to ③ in the above Figure and push "OFF" 5 times to return to the normal mode.

In the case of Remote Controller (Part No. 220-5410):

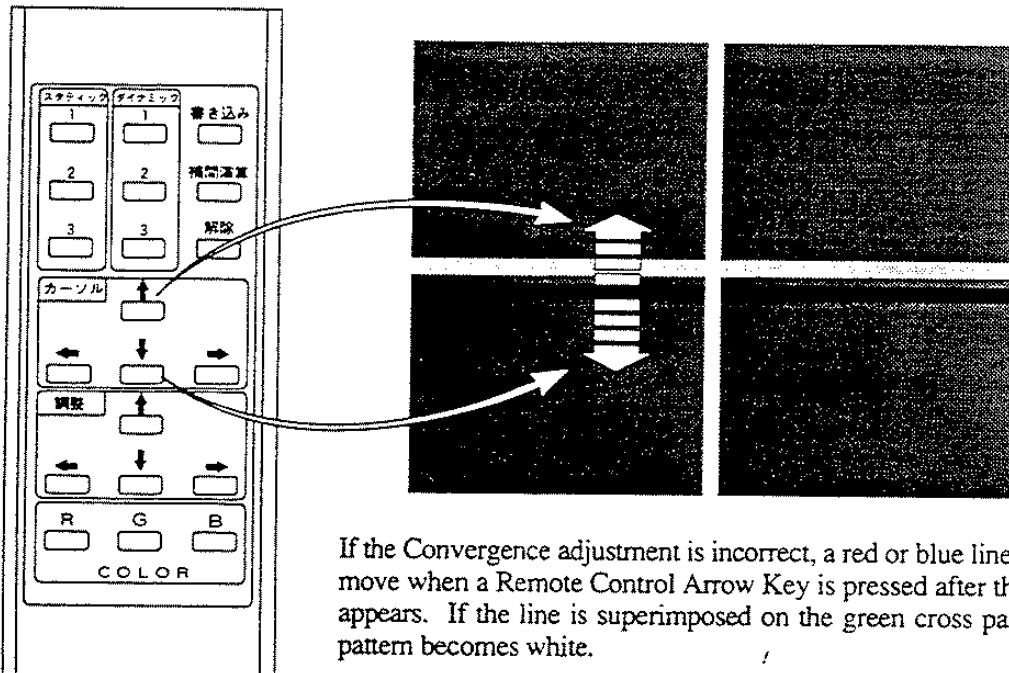

If the Convergence adjustment is incorrect, a red or blue line may appear to move when a Remote Control Arrow Key is pressed after the cross pattern appears. If the line is superimposed on the green cross pattern, the cross pattern becomes white.

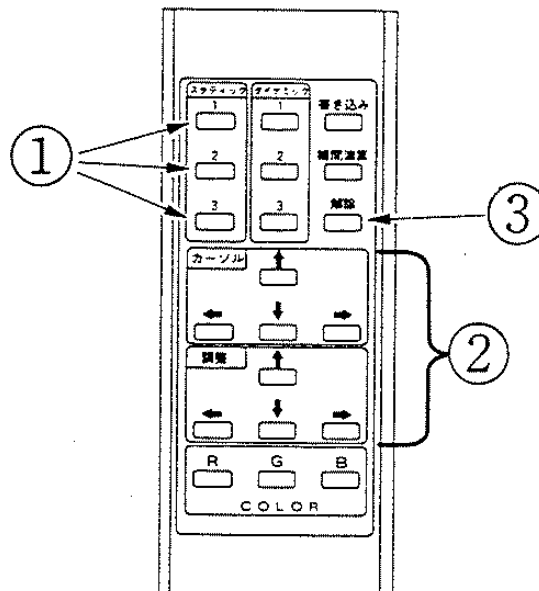

- ① Have the Remote Controller face the Projector screen and press Key 1, 2, and 3 (Portion ① shown) of the Static Convergence Adjustment sequentially in order, causing the cross pattern to be displayed.
- ② Press the following arrow keys (Portion ② shown) to make adjustments.
 - Causes the red horizontal line to match with the green horizontal line.
 - Causes the red vertical line to match with the green vertical line.
 - Causes the Blue horizontal line to match with the green horizontal line.
 - Causes the Blue vertical line to match with the green vertical line.
- ③ Press the CANCEL Key (Portion ③ shown) 5 times. This operation allows for returning to the original screen and at the same time storing the adjustment data.

14. REPLACEMENT OF FLUORESCENT LAMP

To replace the Fluorescent Lamp, remove the Billboard Case by referring to ① and ② of 13-1 REMOVING THE MONITOR MASK.

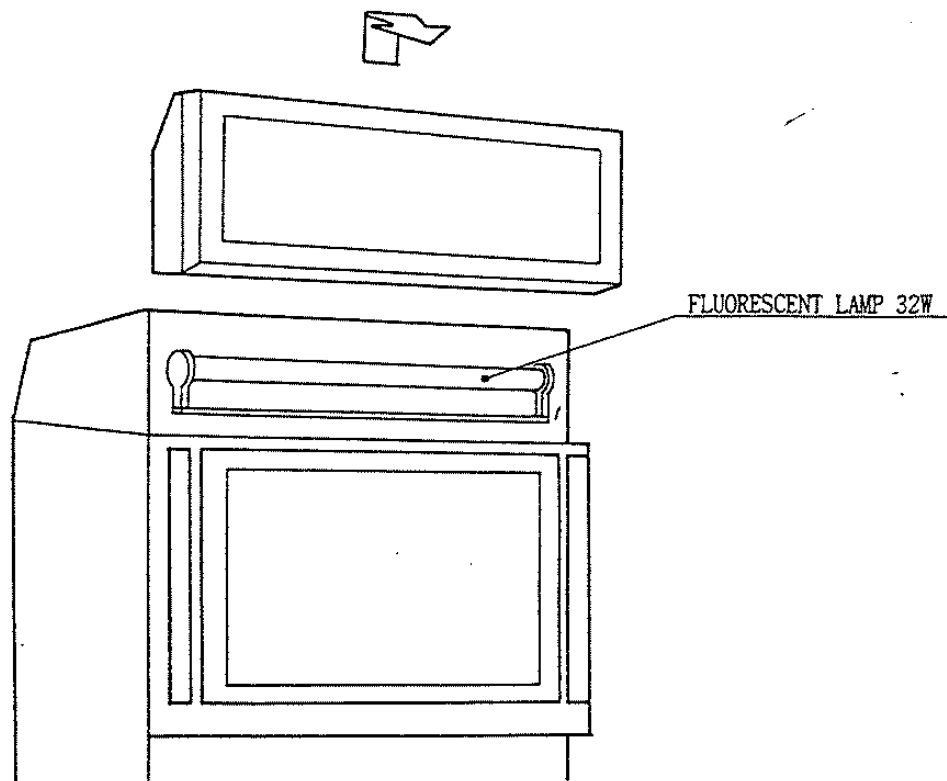

FIG. 14

15. PERIODIC CHECK

The items listed below require periodic check and maintenance to retain the performance of this machine and to ensure safe business operation.

	Item	Interval	Reference
CONTROL PANEL	Check lamp.	Monthly	8
	Check VOLUME VALUE.	Monthly	6, 8
	Check ADJUST GEAR engagement.	Trimonthly	9-1
	Greasing of GEAR.	Trimonthly	9-2, 9-3
ACCEL. & BRAKE	Check VOLUME VALUE.	Monthly	6, 8
	Check ADJUST GEAR engagement.	Trimonthly	11-1
	Greasing of GEAR and bearing.	Trimonthly	11-2
SHIFT LEVER	Check SW.	Monthly	6, 8
	Greasing	Trimonthly	10-3
FRONT CABINET	Check COIN SW.	Monthly	8
	Coin insertion test.	Monthly	12
	Cleaning of COIN SELECTOR.	Trimonthly	12
PROJECTOR	Check adjustments.	Monthly	6, 8, 13
	Cleaning of screen.	Weekly	13-3
	Cleaning of glass	Appropriate time	13-2
GAME BD	MEMORY TEST.	Monthly	8
	Check settings.	Monthly	8
REAR CABINET	Grease the Seat Rail portion.	Trimonthly	See below

REAR CABINET (Greasing to Seat Rail Portion)

Move the Seat to the rearmost portion and apply spray greasing to the portion shown at the right once every 3 months

After greasing, move the Seat a few times forward and backward so as to allow the grease to be applied all over uniformly. Be sure to wipe grease which attaches to the surfaces of the PROTECT RUBBER on the Seat Rail, or any excess grease.

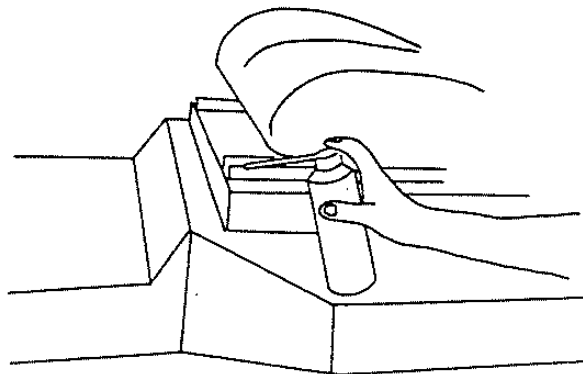

FIG. 15

16. TROUBLESHOOTING

In case a problem occurs, first check wiring connector connections.

PROBLEMS	CAUSE	COUNTERMEASURES
When the main SW is turned ON, the machine is not activated.	The power is not ON.	Firmly insert the plug into the outlet.
	Incorrect power source/voltage.	Make sure that the power supply/voltage are correct.
	The CIRCUIT PROTECTOR functioned due to momentary overcurrent.	Reset the AC Unit's Circuit Protector.
PTV screen color is not correct	Screen adjustment is not appropriate.	Make adjustments appropriately.
PTV screen has a color deviation.	Affected by the periphery, such as other machines, location building's steel frames, etc.	Make convergence adjustments.
		Change installation direction/ position.
		Move the other machines which causes the problem.
No image is projected on the PTV screen.	Connector connection is incorrect.	Check connector connection inside the Roof Lid and Front Panel L.
Sound is not emitted.	Sound volume adjustment is not correct.	Adjust SW Unit's speaker volume.
	Malfunctioning BD. and Amp.	Perform sound test to check it.
	Connector connection is incorrect.	Check the connector connection inside the Roof Lid.
Woofer sound is not emitted.	Sound volume adjustment is incorrect.	Adjust SW Unit's woofer volume.
	Connector connection is incorrect.	Check connector connection inside the Roof Lid, and Front & Rear cabinets.
Operation of Accel., Brake and Pedal are not satisfactory.	V. R. position deviated.	Adjust V. R. value in the test mode.
	V. R. malfunctioning.	Replace the V. R.
	ADJUST GEAR's engagement is not correct.	Adjust the engagement of ADJUST GEAR.
SHIFT LEVER doesn't operate satisfactorily.	Switch malfunctioning.	Replace the SW.
Steering Wheel reaction strength is incorrect. Deviation of Center.	Power ON check not performed correctly.	Turn off power and then turn it back on again. Complete the power on check.
	V. R. position deviated.	Adjust V. R. value in the test mode.
	V. R. malfunctioning.	Replace the V. R.

PROBLEMS	CAUSE	COUNTERMEASURES
Steering Wheel reaction strength is insufficient.	Reaction Mecha's secular change.	Change Drive Control BD DIP SW setting.
No Steering Wheel Reaction.	Connector Connection is incorrect.	Check connector connection in the Roof Lid, Front Panel L, and Service Door.
	The Motor Drive BD fuse is blown due to momentary overcurrent.	Replace the Motor Drive BD Fuse.
Fluorescent lamp does not light up.	Fluorescent Lamp needs replacement.	Replace the fluorescent lamp.
	Connector connection is incorrect.	Check connector connection in the Roof Lid.



Be sure to turn off power before performing the work.

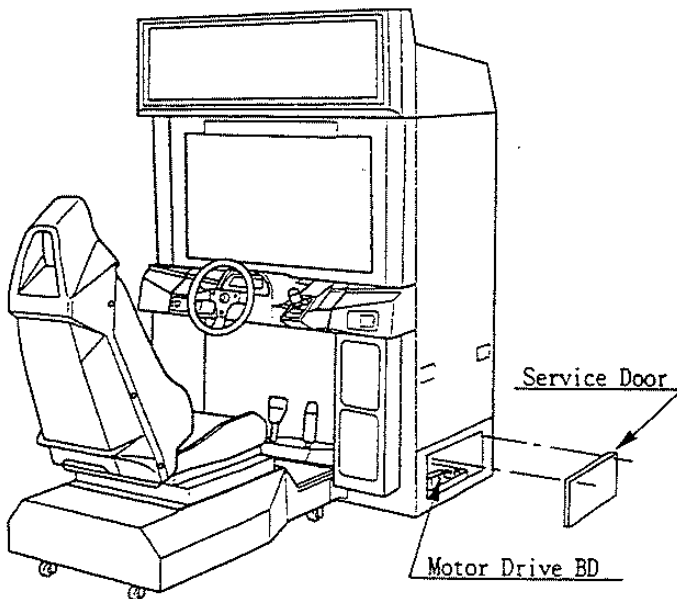

To replace the Motor Drive BD Fuse, open the Front Cabinet's right-hand side Service Door.

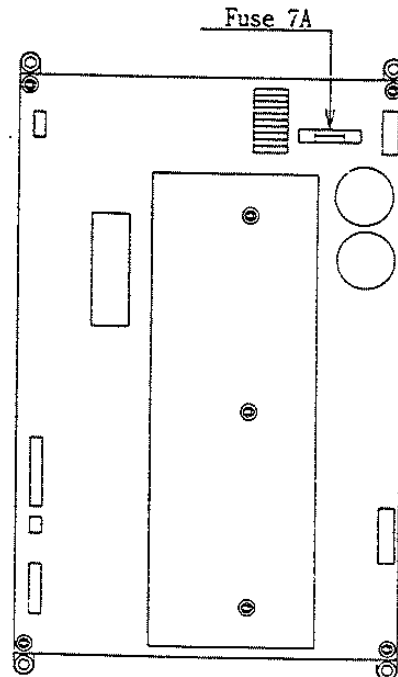

Be sure to use the specified fuse for the Motor Drive BD (838-11966).

17. GAME BOARD

17 - 1 REMOVING THE BOARD

To replace or check the Game Board, remove it by using the following procedure:

- ① Turn off the Main SW.
- ② Remove the 2 Truss Screws from the Roof Lid and open the Roof Lid with the Master Key.
- ③ Take out the 3 Screws and remove the Shield Case Lid from the Shield Case in the center. The Game Board can be viewed.
- ④ Take out the 5 screws to remove the Shield Case Lid which is beside the Case Lid in the center, and the Drive Control BD appears.

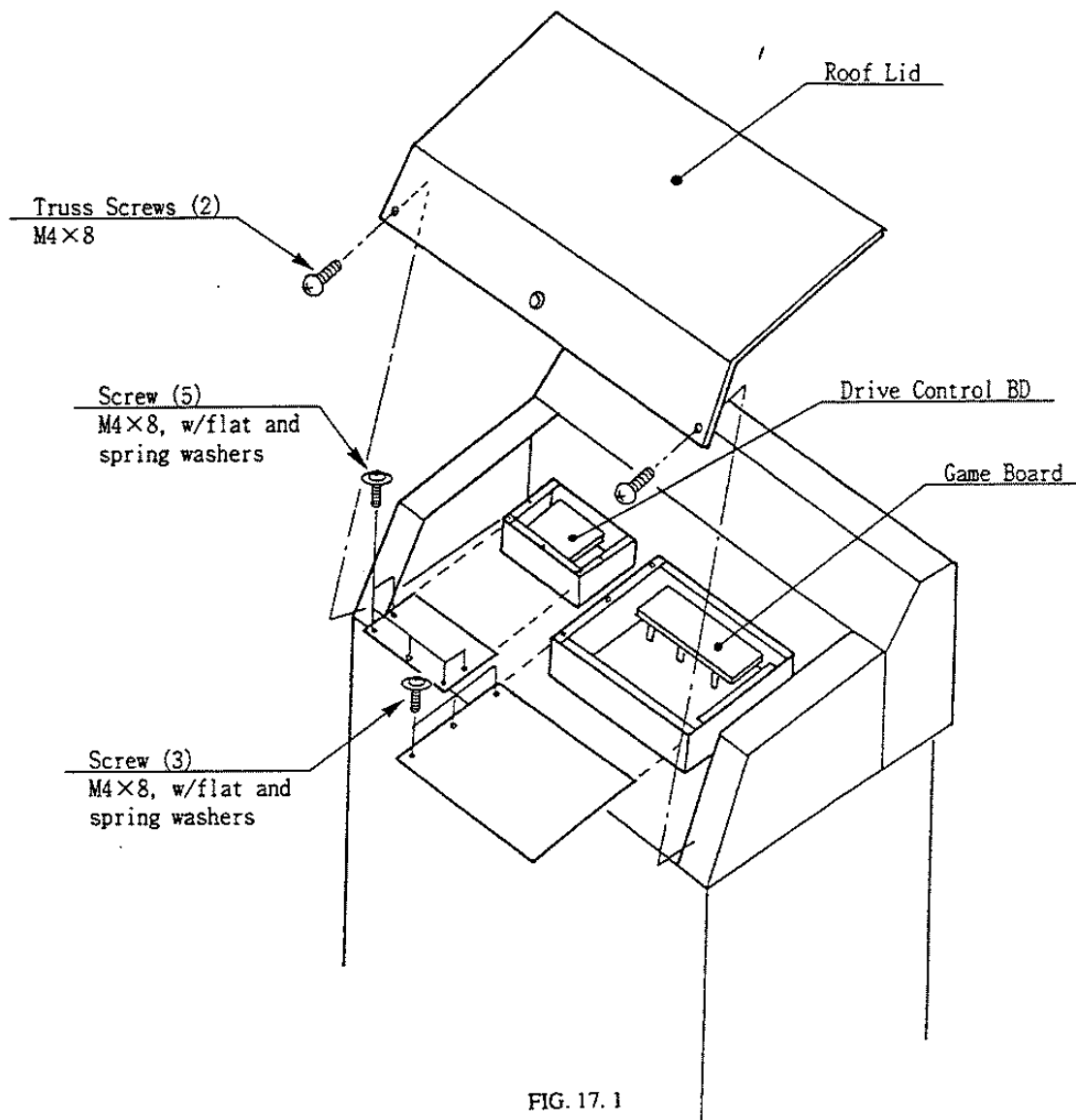

17 - 2 COMPOSITION OF GAME BOARD

GAME BD INDY 500 (833 - 11992)

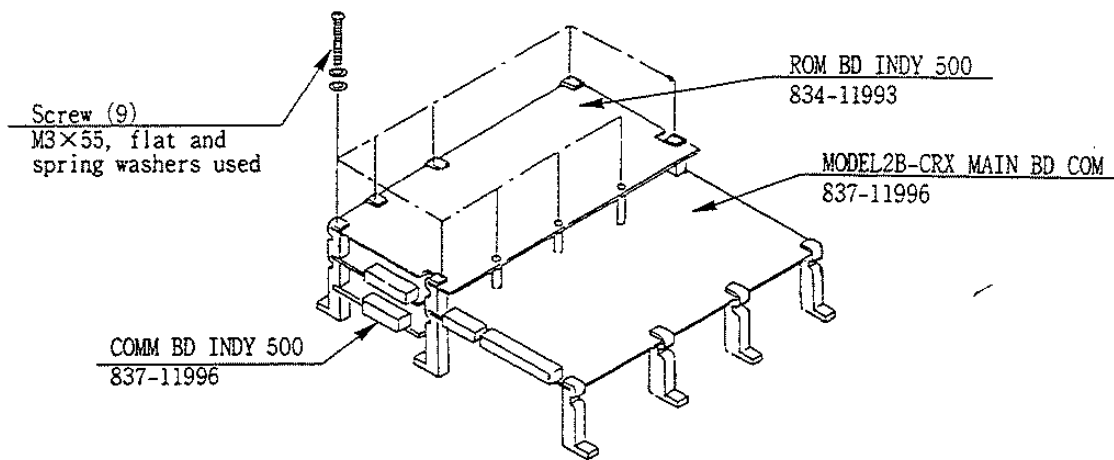
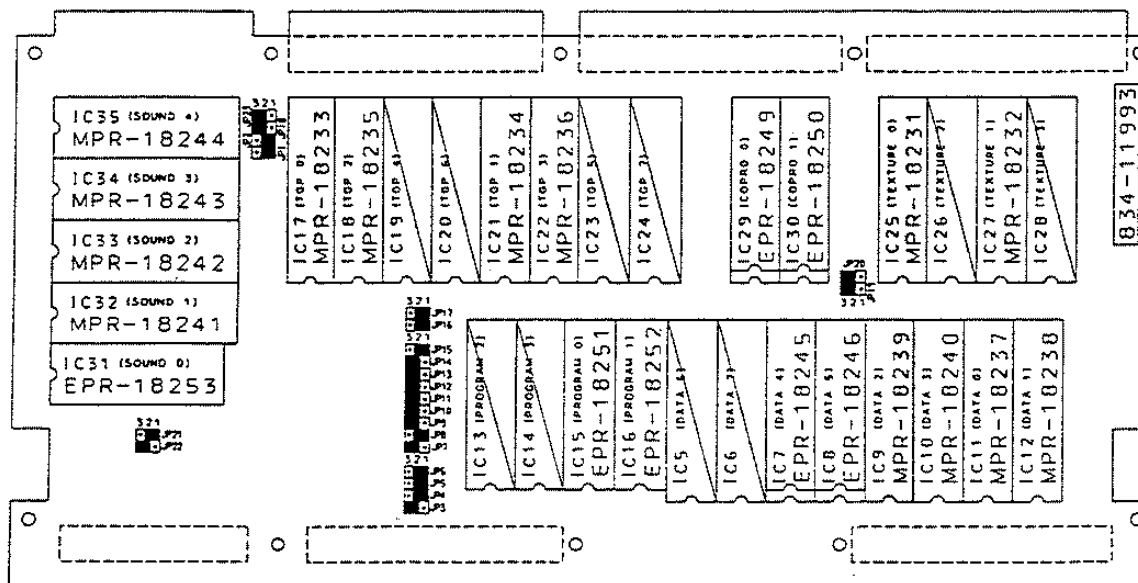

FIG. 17. 2

ROM BD INDY 500 (833 - 11993)



17 - 3 INPUT AND OUTPUT RELATIONS

INDY 500

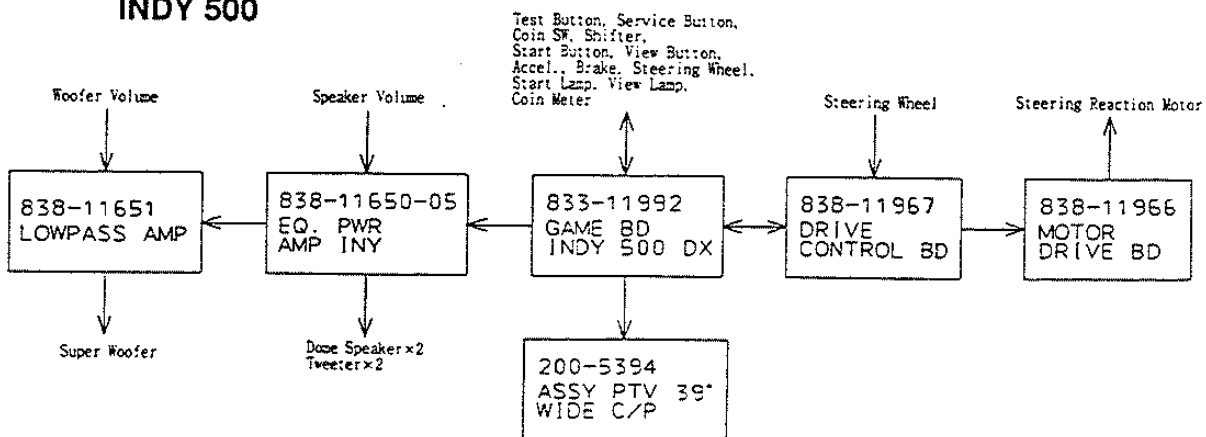
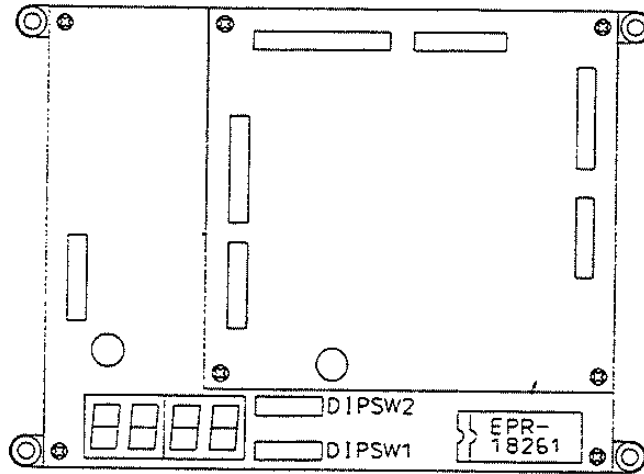

FIG. 17. 3

DRIVE CONTROL BOARD

The Steering Wheel reaction strength is set by the Drive Control Board DIP SW.
 To perform the setting, open the Billboard and remove the Lid of the Shield Case for the Drive Control BD. Be sure to turn off power before performing the work.
 Use Nos. 1~3 of DIP SW 1 of the Drive Control BD. Turn off all other DIP SWes.



DRIVE CONTROL BD (838-11967)

DIP SW SETTING

NOTE: The shaded portion refers to the setting at the time of shipment.

1	2	3	FUNCTION
OFF	OFF	OFF	Light
ON	OFF	OFF	↑
OFF	ON	OFF	
ON	ON	OFF	↓
OFF	OFF	ON	
ON	OFF	ON	Heavy
ON	ON	ON	

18. DESIGN RELATED PARTS

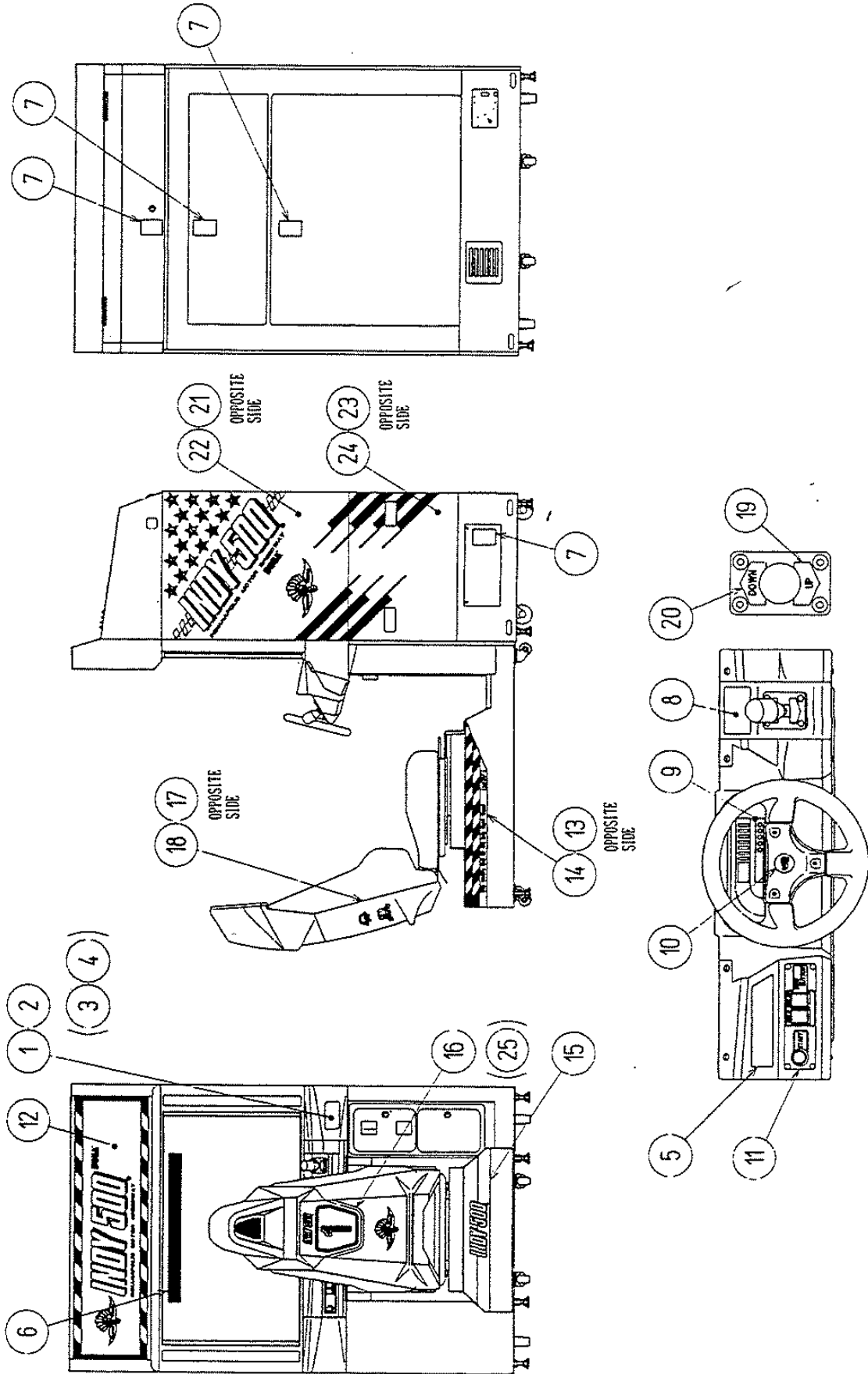

<u>NO.</u>	<u>PART NO.</u>	<u>DESCRIPTION</u>
1	DYN-0010	DENOMI PLATE
5	422-0536-01	PLAY INSTR SH INY ENG
6	4220-0537-01	SUB INSTR SH INY ENG
8	4400-CS0011-EG	STICKER C GRIP HANDLE ENG
9	INY-1201-B	SHEET METER
10	INY-1203-B	SHEET EMBLEM
11	INY-1251-B	SHEET VR SW
12	4230-0249	BILLBOARD PLATE INY
13	INY0-1502-B	STICKER BASE LINE L
14	INY0-1502-C	STICKER BASE LINE R
15	INY0-1502-D	STICKER BASE LINE B
16	INY0-1604-B	STICKER BASE LINE CENTER
17	INY0-1604-C	STICKER SEAT L
18	INY0-1604-D	STICKER SEAT R
19	421-8890	DESIGN PLT SHIFT UP
20	421-8891	DESIGN PLT SHIFT DOWN
21	421-8901	STICKER INY PTV L
22	421-8902	STICKER INY PTV R
23	421-8930	STICKER INY PTV LOWER L
24	421-8931	STICKER INY PTV LOWER R
25	4210-8935	STICKER INDY CAR No. "2-8" (for use with linked machines)

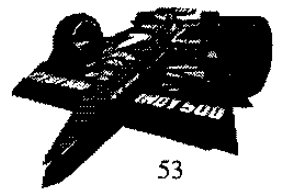

19. COMMUNICATION PLAY

INDY 500 allows 2~8 units to be linked for interactive play.
For communication play, communication cable connection and Game Assignments are needed.

19 - 1 INSTALLATION PRECAUTIONS

When linking a number of machines, be sure to supply sufficient power for the corresponding number of machines. The per unit standard voltage/ampereage is 100~120V/10A and 200~240V/5A. Remove the Hole Lid which is beside the BILLBOARD (only for the Communication Cable passage side).

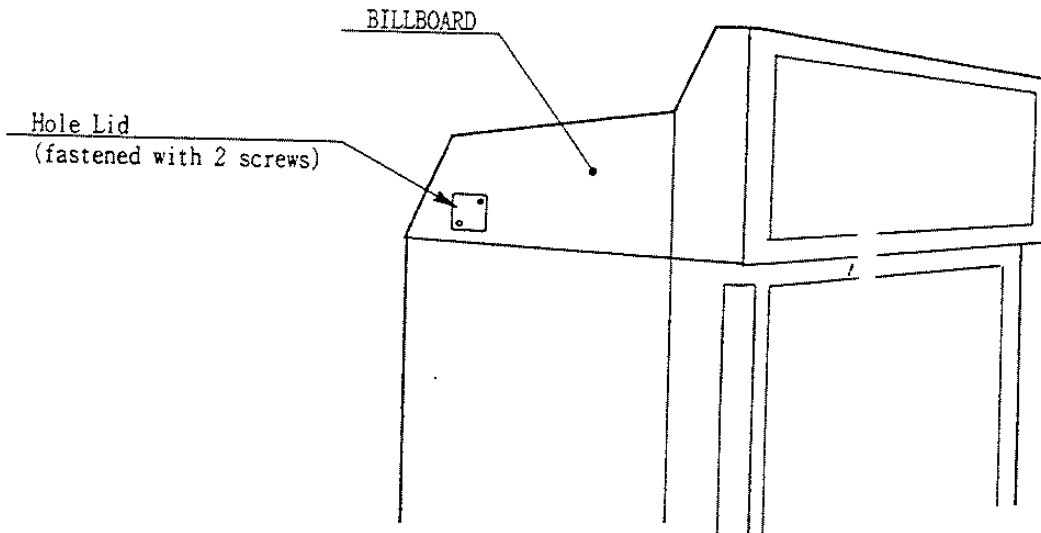
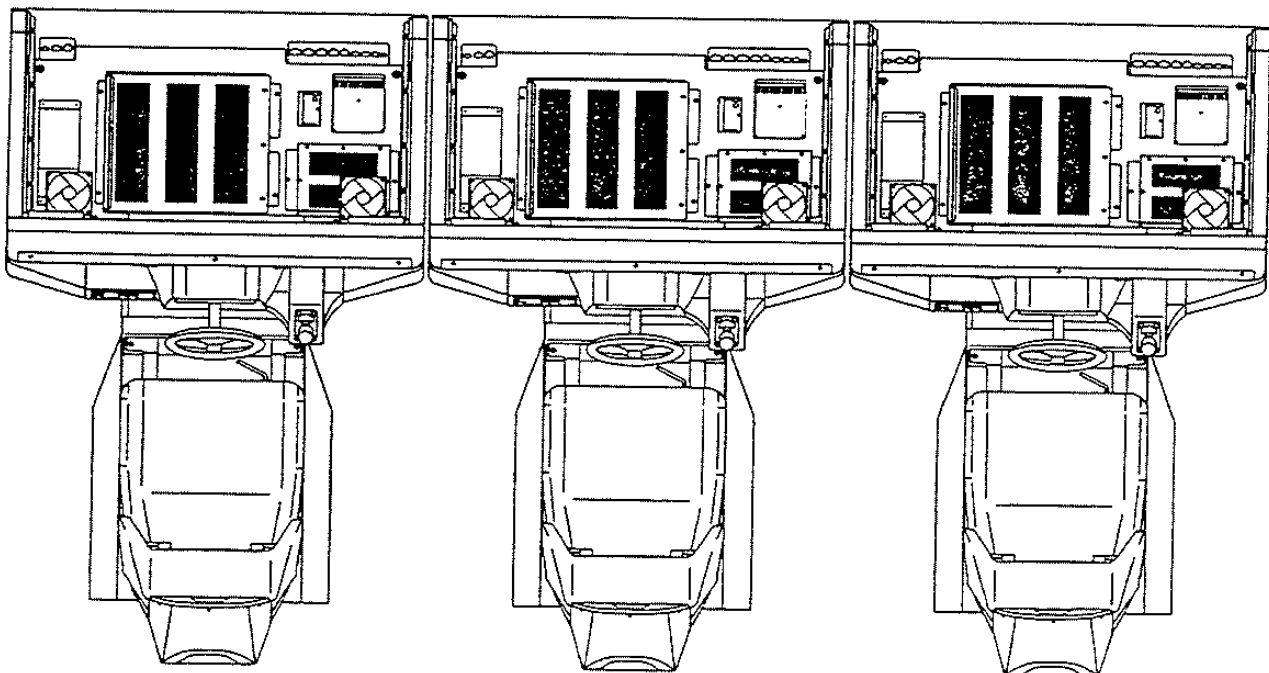

FIG. 19. 1

Install the machines by referring to the following illustrations.



Ensure that the height and depth of the machines are consistent with each other so that the holes beside the Billboards also match.

19 - 2 CONNECTING THE COMMUNICATION CABLES



The Communication cables are made of Optic Fiber. Excessive bending can damage it. Handle with care.

Open the Billboard's Roof Lid and connect the Communication Cable to the Shield Case for the Game BD (refer to FIG. 19.2 a).

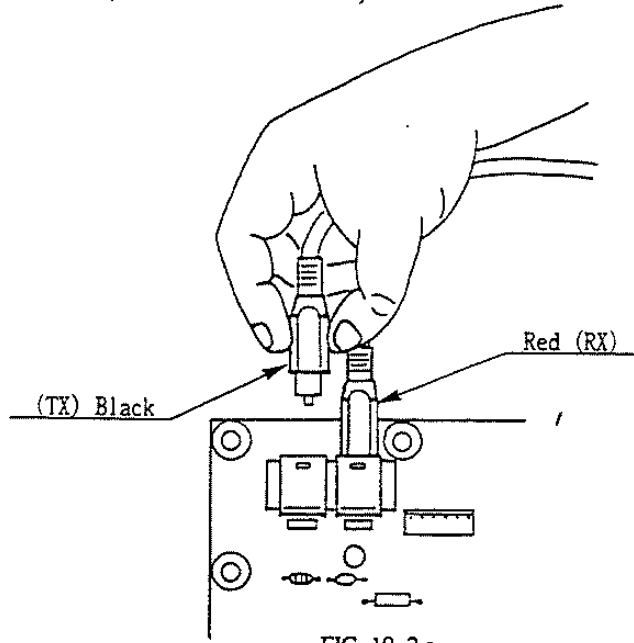
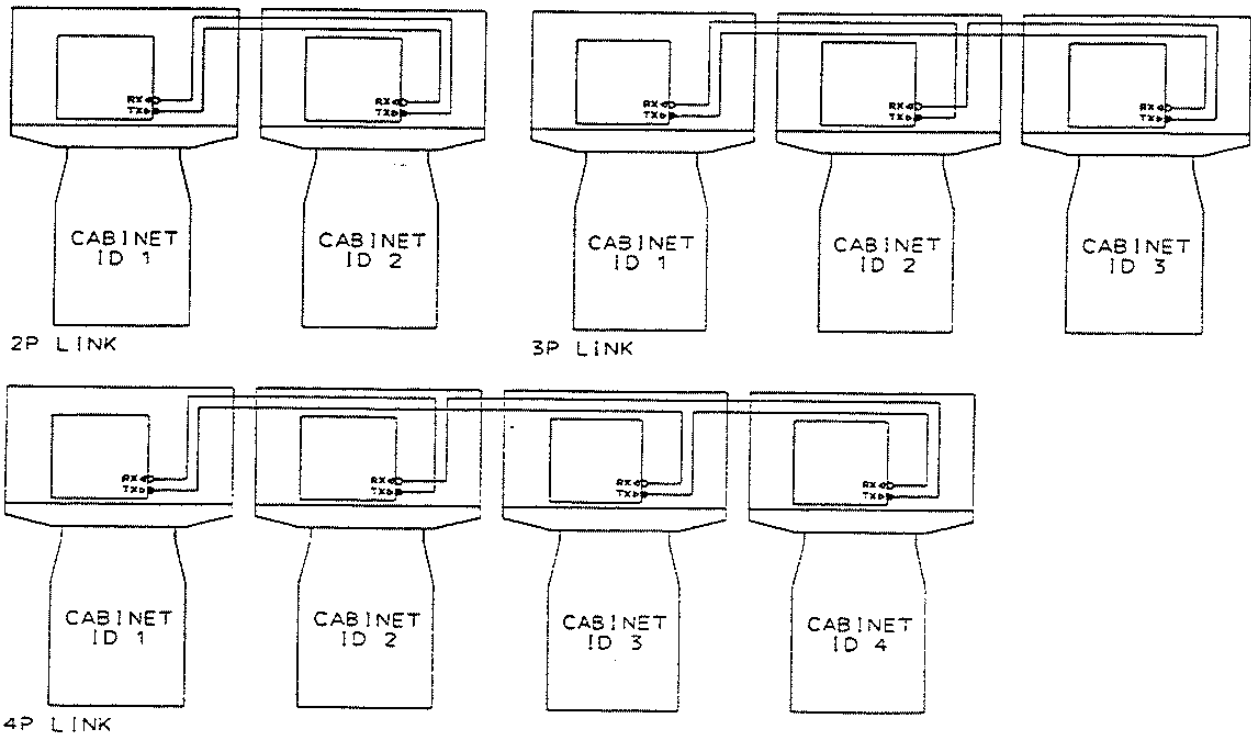
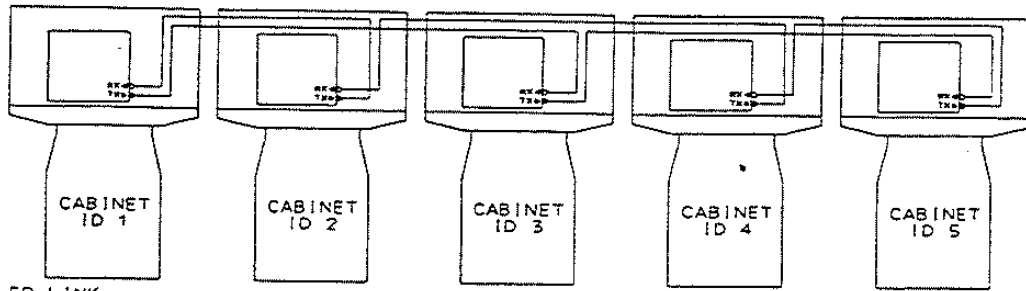

FIG. 19.2 a

Depending on the number of machines to be linked, connect Communication cables as shown in FIG. 19.2 b.





5P LINK

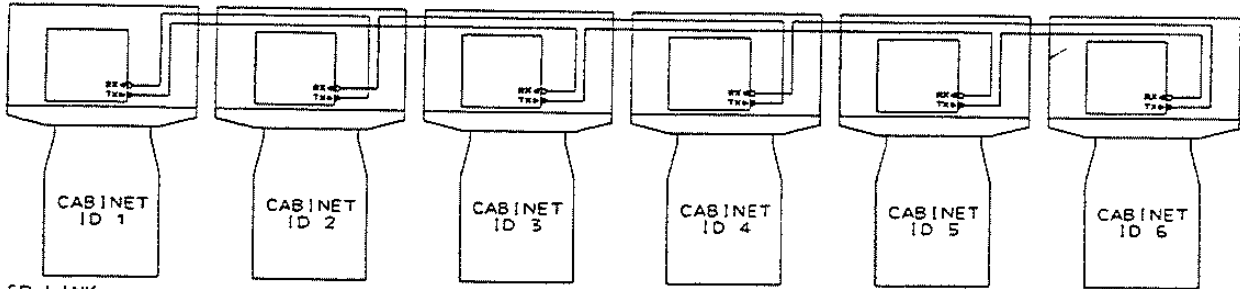

6P LINK

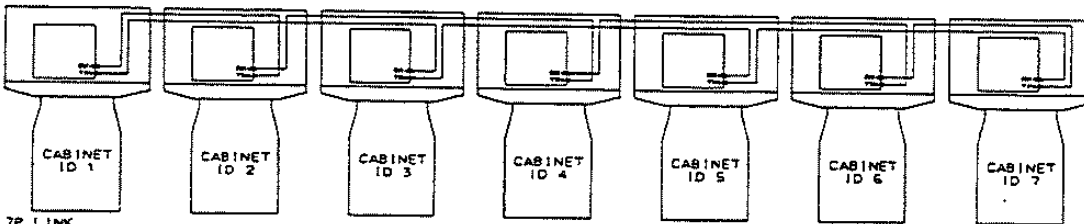

7P LINK

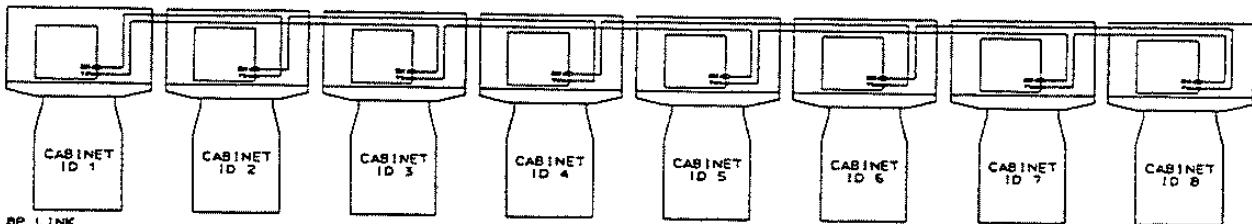

8P LINK

FIG. 19.2 b

19 - 3 SETTING COMMUNICATION PLAY



When communications are stopped during interactive play, due to some cause, the game will be interrupted and the Network Check mode will appear on the screen.

When performing communication play, GAME ASSIGNMENTS in the Test mode need to be changed. First determine the Master unit and set the NETWORK TYPE to MASTER. Thereafter, the settings of Game Difficulty, Race mode, Handicap, Advertise Sound, and Country must follow the settings made by the Master Unit. Next, Cabinet ID is set sequentially in order of 1 • 2 • 3 ... starting from the leftmost unit.

GAME ASSIGNMENTS	
GAME DIFFICULTY	NORMAL /
RACE MODE	NORMAL
HANDICAP	ON
ADVERTISE SOUND	ON
COUNTRY	EXPORT
CABINET TYPE	DELUXE
NETWORK TYPE	MASTER
CABINET ID	1

SELECT WITH SERVICE BUTTON
AND PRESS TEST BUTTON

FIG. 19.3

Have all the machines exit from the Test Mode. The Network Check starts and after a while, the game mode appears on the screen.

19 - 4 APPLICATION OF STICKER

Apply the Seat No. displaying Sticker Numbers 2~8 (421-8935) to the positions shown sequentially in order of 1, 2, 3, 4 starting from the leftmost linked unit (facing the screen).

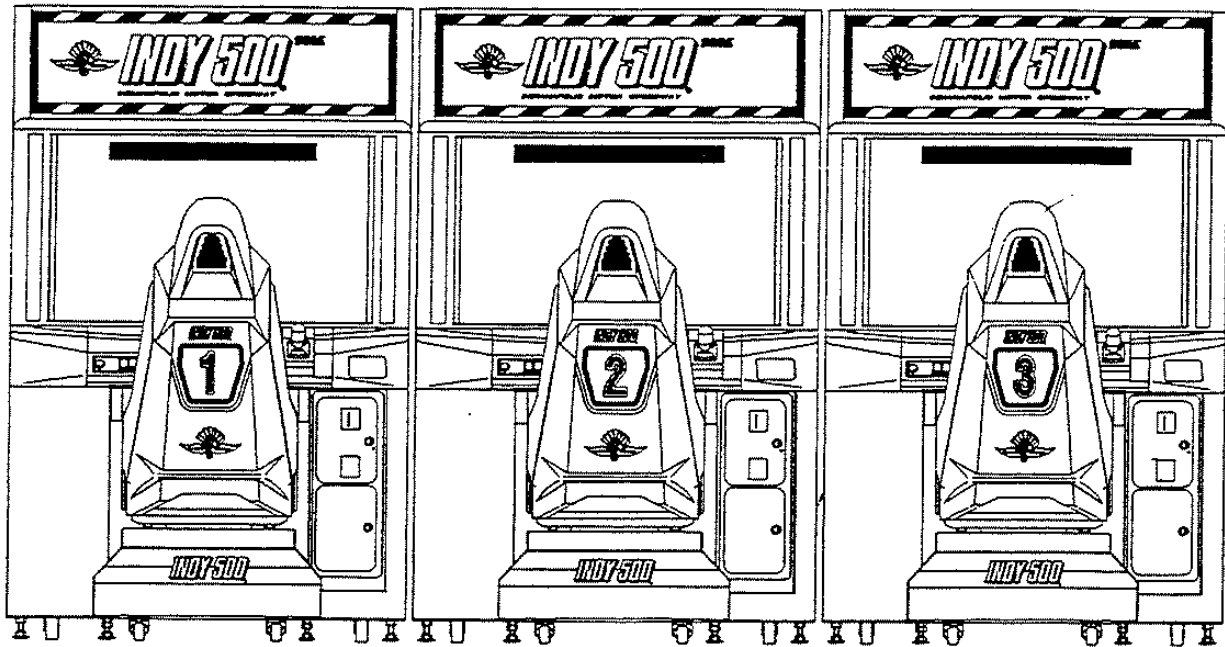

FIG. 19. 4

20. PARTS LIST
INDY 500 DELUXE ASSEMBLY

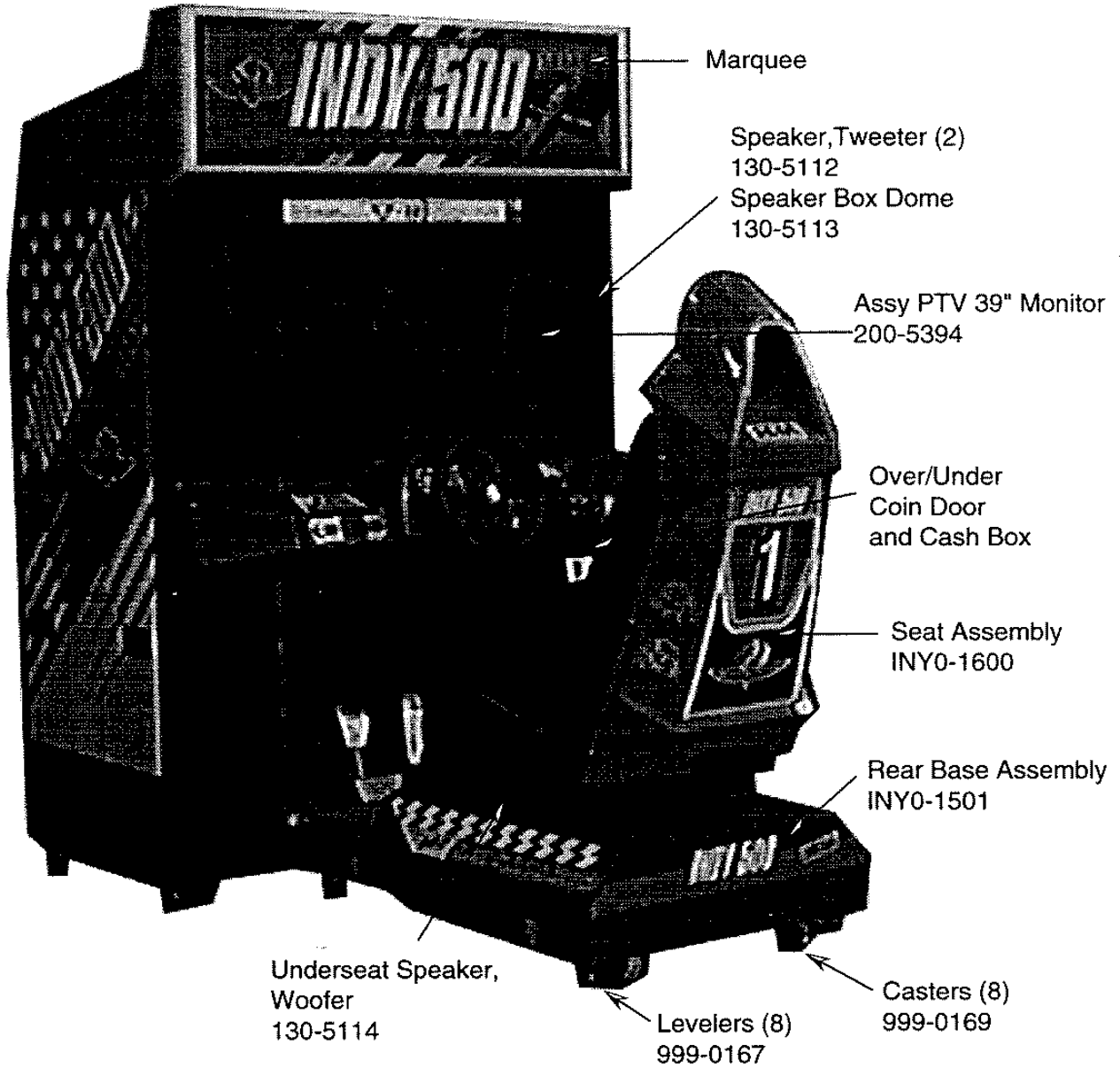
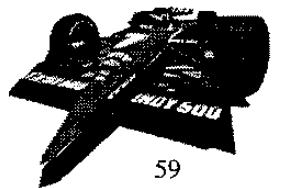

FIGURE 20-1: INDY 500 DELUXE CABINET ASSEMBLY



GAS AND BRAKE PEDAL ASSEMBLY P/N: DYN1-1300

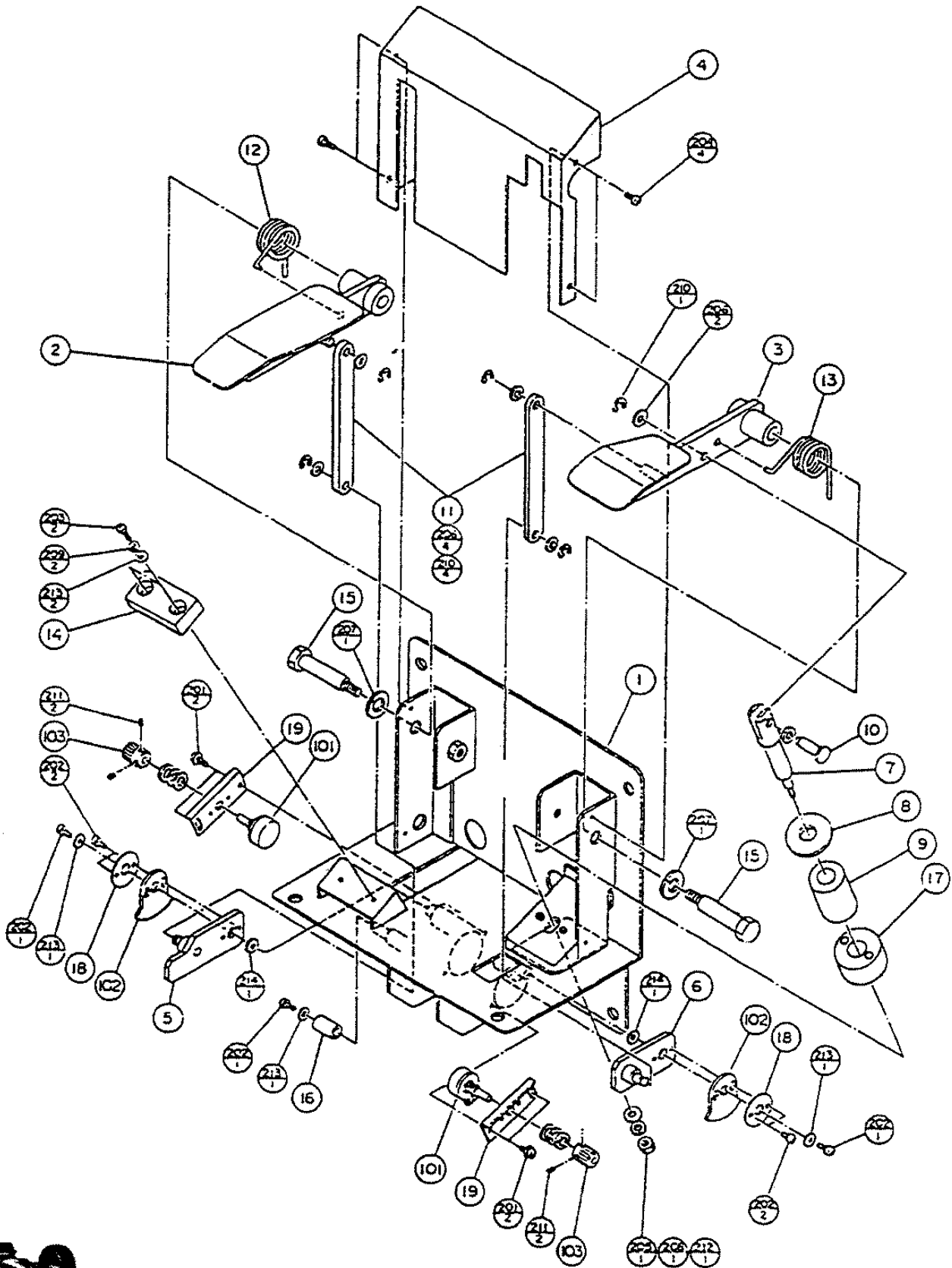
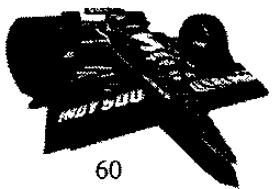

FIGURE 20-2: GAS AND BRAKE PEDAL ASSEMBLY



GAS AND BRAKE PEDAL ASSEMBLY P/N: DYN1-1300

Table 20:-1 Gas and Brake Pedal Parts List

<u>NO.</u>	<u>PART NO.</u>	<u>DESCRIPTION</u>
1	DYN0-1301	PEDAL BASE
2	DYN0-1306	ACCEL PEDAL
3	DYN0-1307	BRAKE PEDAL
4	BVG0-1404	PEDAL COVER
5	BVG0-1405	SWING ARM A
6	BVG0-1406	SWING ARM B
7	BVG0-1407	PUSH ROD
8	BVG0-1408	PUSH PLATE
9	DYN-1302	RUBBER BUMPER
10	BVG0-1410	PUSH ROD PIN
11	BVG0-1411	LINK ROD
12	DYN0-1303	TORSION SPRING ACCEL
13	BVG0-1413	TORSION SPRING B
14	BVG0-1414	RUBBER STOPPER
15	BVG0-1415	PEDAL SHAFT
16	BVG0-1416	SWING ARM STOPPER
17	BVG0-1417	SPACER
18	GLC0-2122	GEAR PLATE
19	RDM-1210	VR BRACKET
101	220-5373	VOL CONT B - 5K OHM
	220-5484	VOL CONT B - 5K OHM ALT
102	601-6005	ADJUST GEAR
103	601-5943	GEAR 20 Ø 15
201	000-P00408-W	M SCREW PH W/FS M4 X 8
202	000-P00408-S	M SCREW PH W/S M4 X 8
203	000-P00416-0B	M SCREW PH BLK M4 X 16
204	000-T004080-0B	TMP PRF SCREW TH BLK M4 X 8
205	050-H00600	NUT HEX M6
206	060-F00800-0B	FLT WASHER BLK M8
207	060-S01200-0B	SPR WASHER BLK M12
208	060-S00600	SPR WASHER M6
209	060-S00400-0B	SPR WASHER BLK M4
210	065-E00600	E RING 6MM
211	028-A00308-P	SET SCR HEX SKT CUP P M3 X 8
212	068-652016	FLT WASHER 6.5-20 X 1.6
213	DYN-1304	FLT WASHER BLK 4.4-12 x 1.6
214	DYN-1305	FLT WASHER 12.2-22 X 0.5

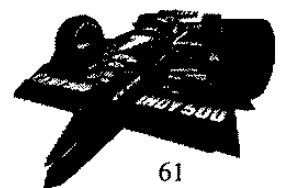

CONTROL PANEL ASSEMBLY P/N: INY-1200

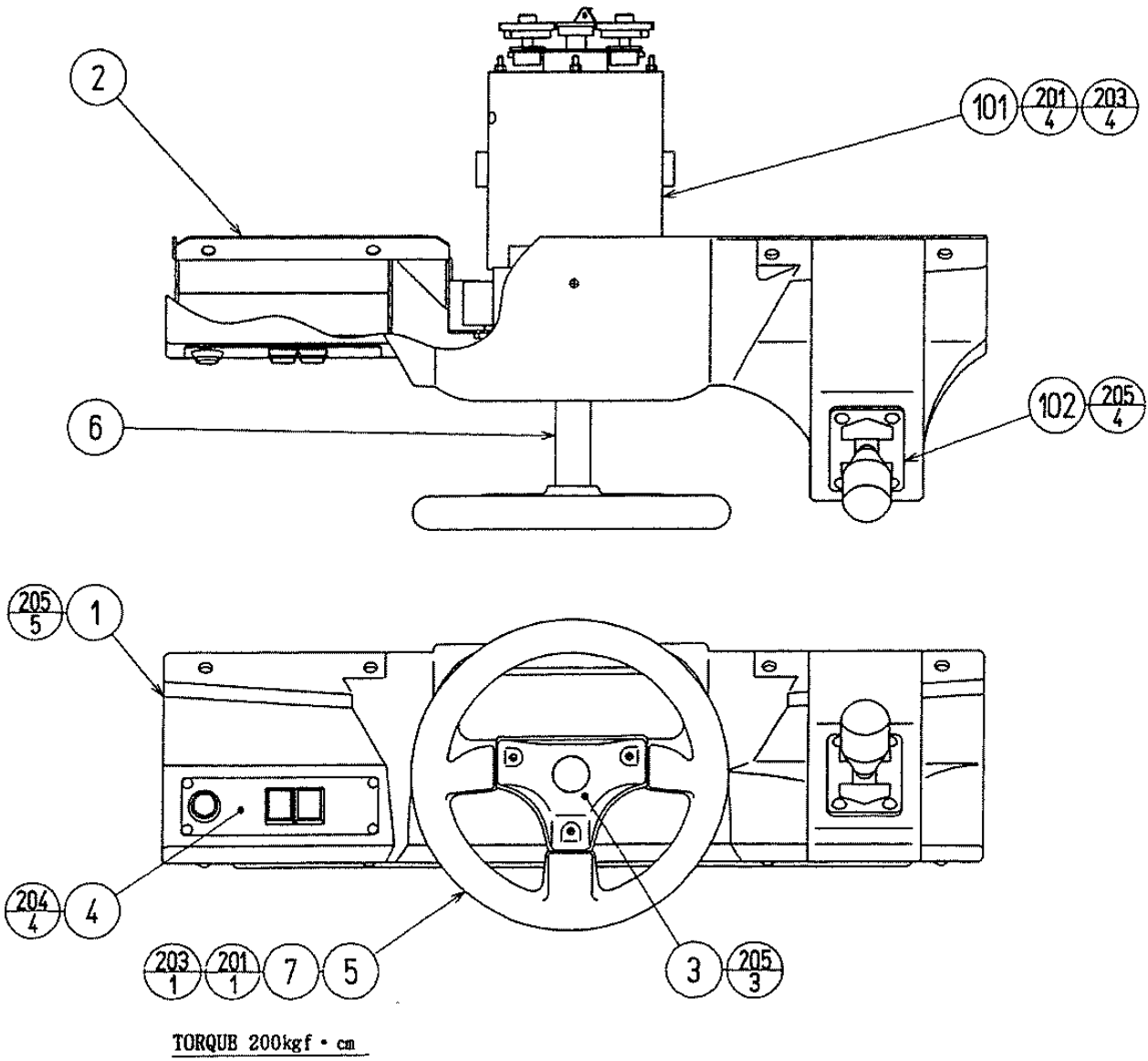
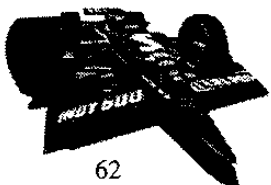

FIGURE 20-4: CONTROL PANEL ASSEMBLY



CONTROL PANEL ASSEMBLY P/N: INY-1200

Table 20-3: Control Panel Parts List

<u>NO.</u>	<u>PART NO.</u>	<u>DESCRIPTION</u>
1	INY-1201	CONTROL PANEL COVER
2	INY-1202	CONTROL PANEL BRKT
3	INY-1203	STEERING EMBLEM
4	INY-1250	ASSY VIRTUAL BUTTON
5	DYN-1201	STEERING WHEEL
6	DYN-1209	HANDLE COLLAR
7	OUT-2026	SPACER
101	610-0383	ASSY HANDLE MECHANISM W/MOTOR
102	6100-0384	UP/DOWN SHIFTER
201	050-H00800	HEX NUT M8
202	050-F00400	FLG NUT M4
203	060-S00800	SPR WSHR M8
204	000-T00412-0C	M SCR TH CRM M4 X 12
205	008-T00512-0B	TMP PRF SCR TH BLK M5 X 12

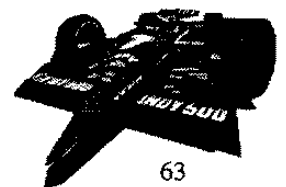

VIRTUA BUTTON ASSEMBLY P/N: INY-1250

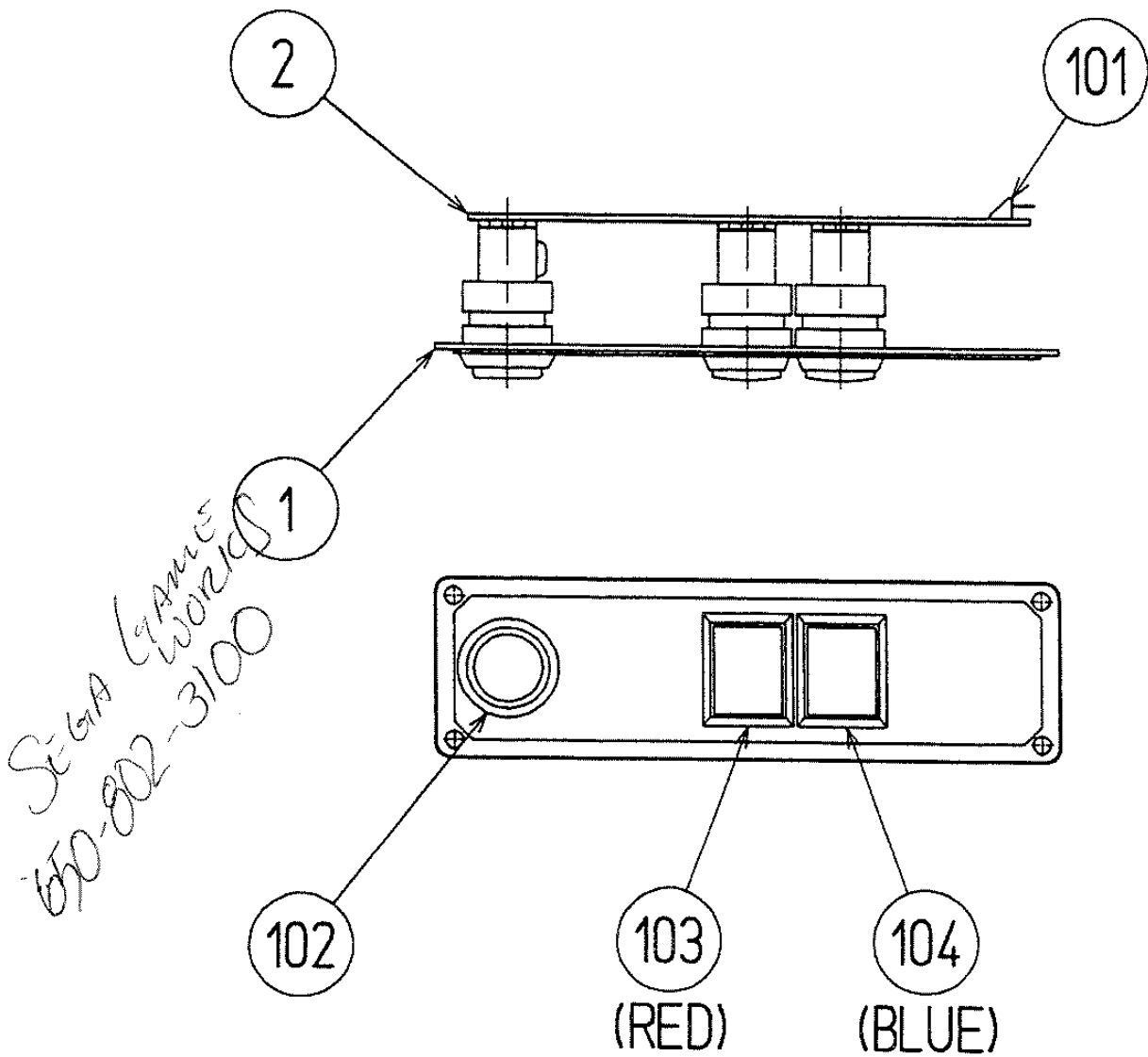
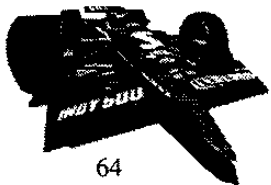

FIGURE 20-5: VIRTUA BUTTON ASSEMBLY

Table 20-4: Virtua Button Parts List

<u>NO.</u>	<u>PART NO.</u>	<u>DESCRIPTION</u>
1	INY-1251	VR SW BRACKET
2	171-6478B	PC BD LIGHTING SWX5
101	212-5205-12	CONN JST M 12P RTA
102	509-5560-Y	PB SW W/L 6V 1L Y
103	509-5561-R	PB SW W/L 6V 5L R
104	509-5561-S	PB SW W/L 6V 5L S



MASK ASSEMBLY P/N: INY0-1300

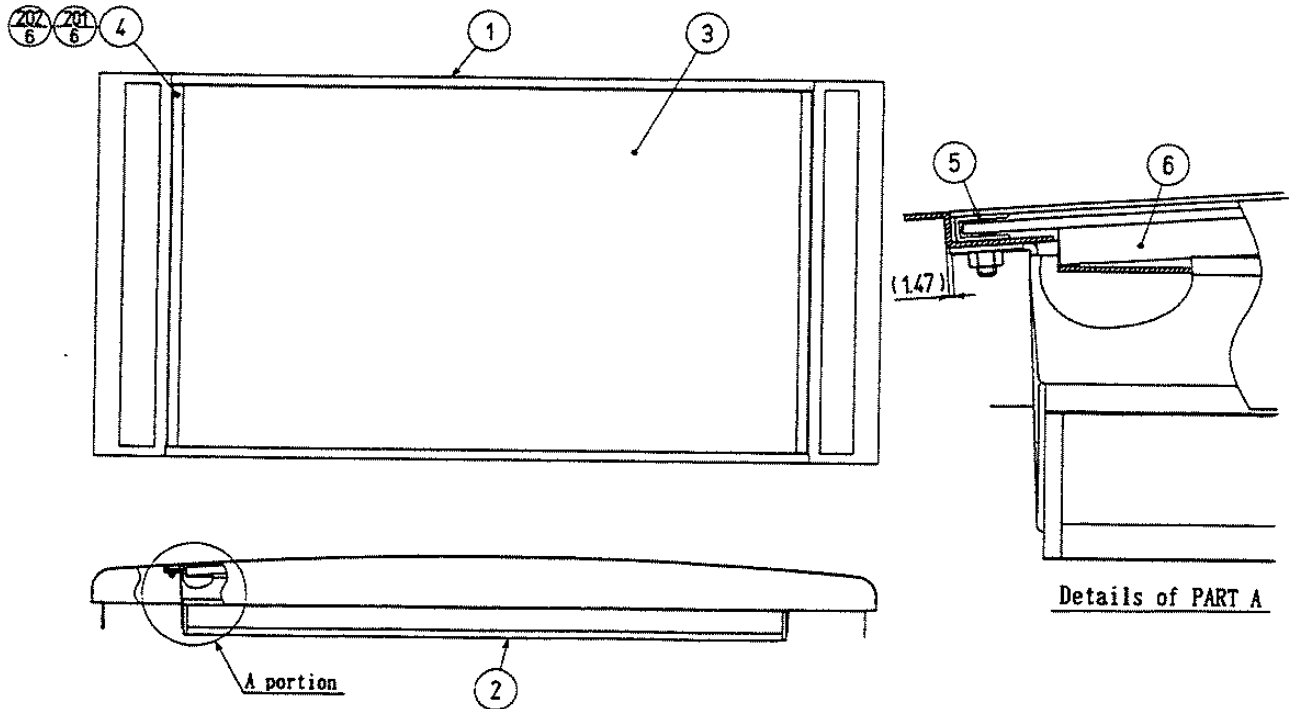
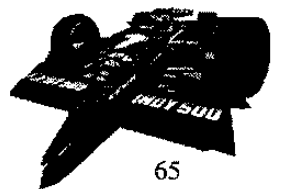

FIGURE 20-6: MASK ASSEMBLY

Table 20-5: Mask Parts List

<u>NO.</u>	<u>PART NO.</u>	<u>DESCRIPTION</u>
1	INY0-1301	MASK FRAME
2	INY0-1302	INNER MASK
3	INY0-1303	FRONT PLEX
4	INY0-1304	CORNER SASH



BILLBOARD CASE ASSEMBLY P/N: INY0-1410

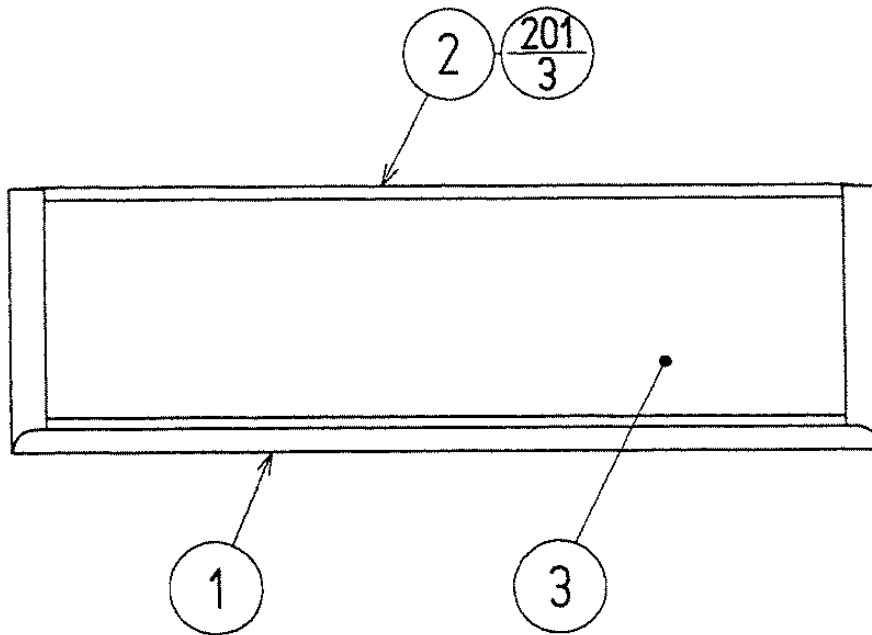
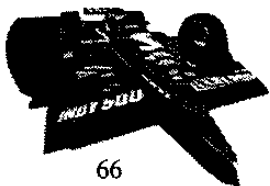

FIGURE 20-7: BILLBOARD CASE ASSEMBLY

Table 20-6: Billboard Case Parts List

<u>NO.</u>	<u>PART NO.</u>	<u>DESCRIPTION</u>
1	INY0-1411	BILLBOARD CASE
2	INY0-1412	CORNER EDGE
3	4230-0249	BILLBOARD PLATE INY



BILLBOARD BASE ASSEMBLY P/N: INY-1420

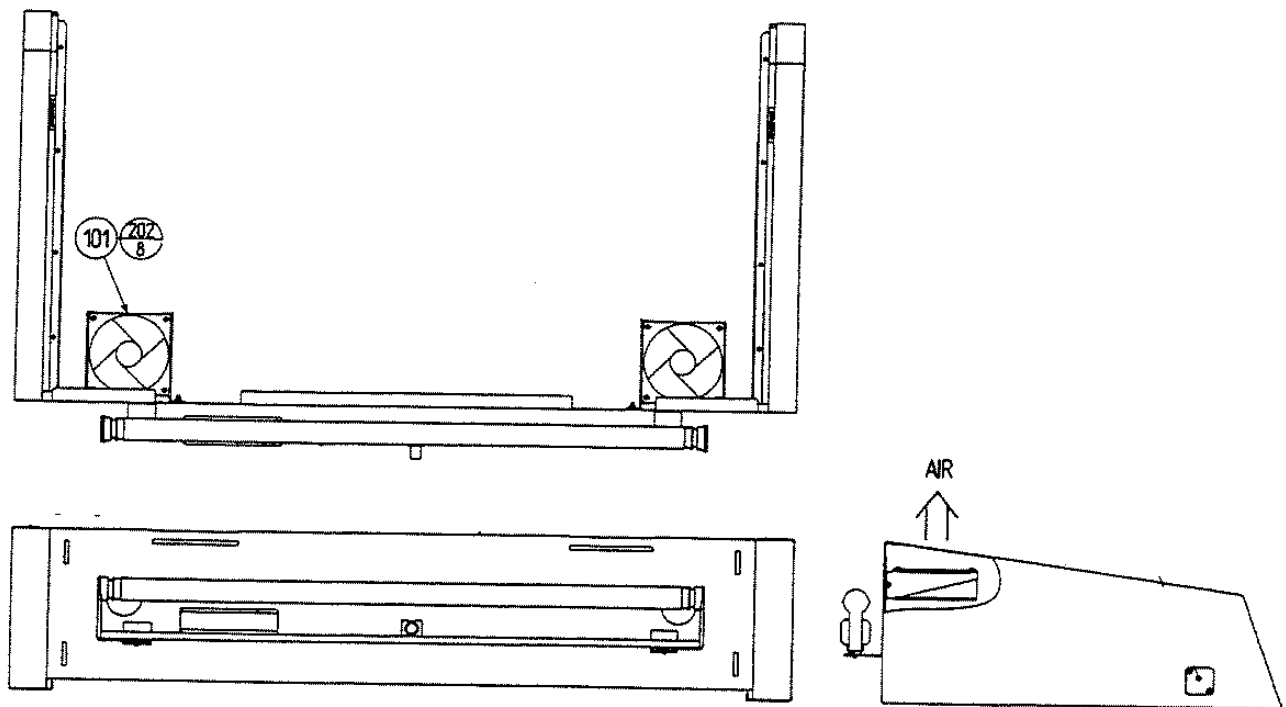
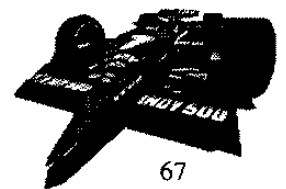

FIGURE 20-8: BILLBOARD BASE ASSEMBLY

Table 20-7: Billboard Base Parts List

<u>NO.</u>	<u>PART NO.</u>	<u>DESCRIPTION</u>
101	2601-0011-02	AXIAL FLOW FAN AC120V50-60HZ 12VDC FL30W 36 INCH FLUORESCENT ASSY



WOOFER ASSEMBLY P/N: INY0-1550

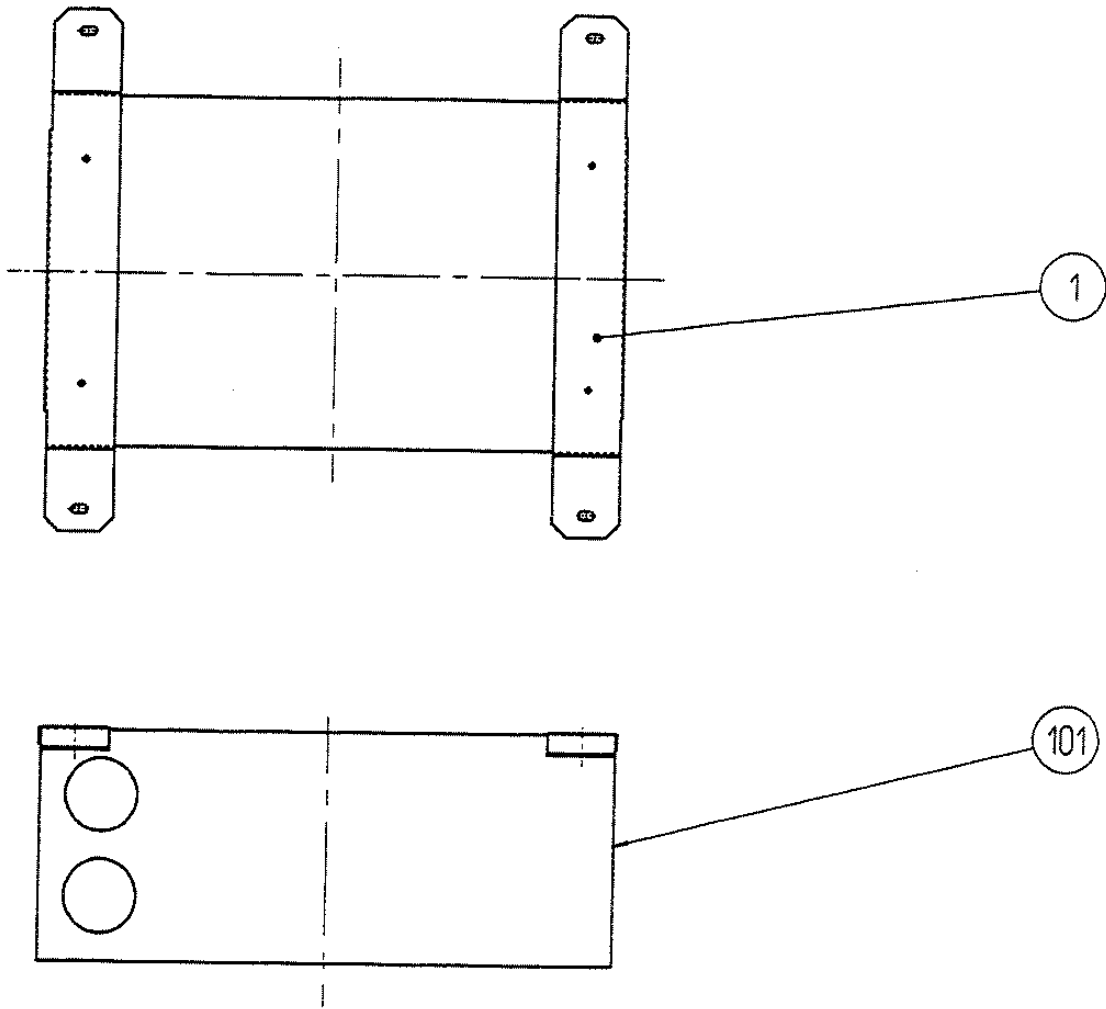
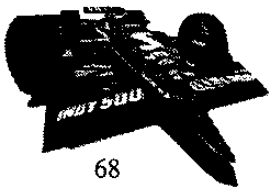

FIGURE 20-12: WOOFER ASSEMBLY

Table 20-11: Woofer Parts List

<u>NO.</u>	<u>PART NO.</u>	<u>DESCRIPTION</u>
1	INY0-1551	WOOFER BRKT
101	130-5097	SPEAKER BOX SUPER WOOFER



SEAT ASSEMBLY P/N: INY0-1600

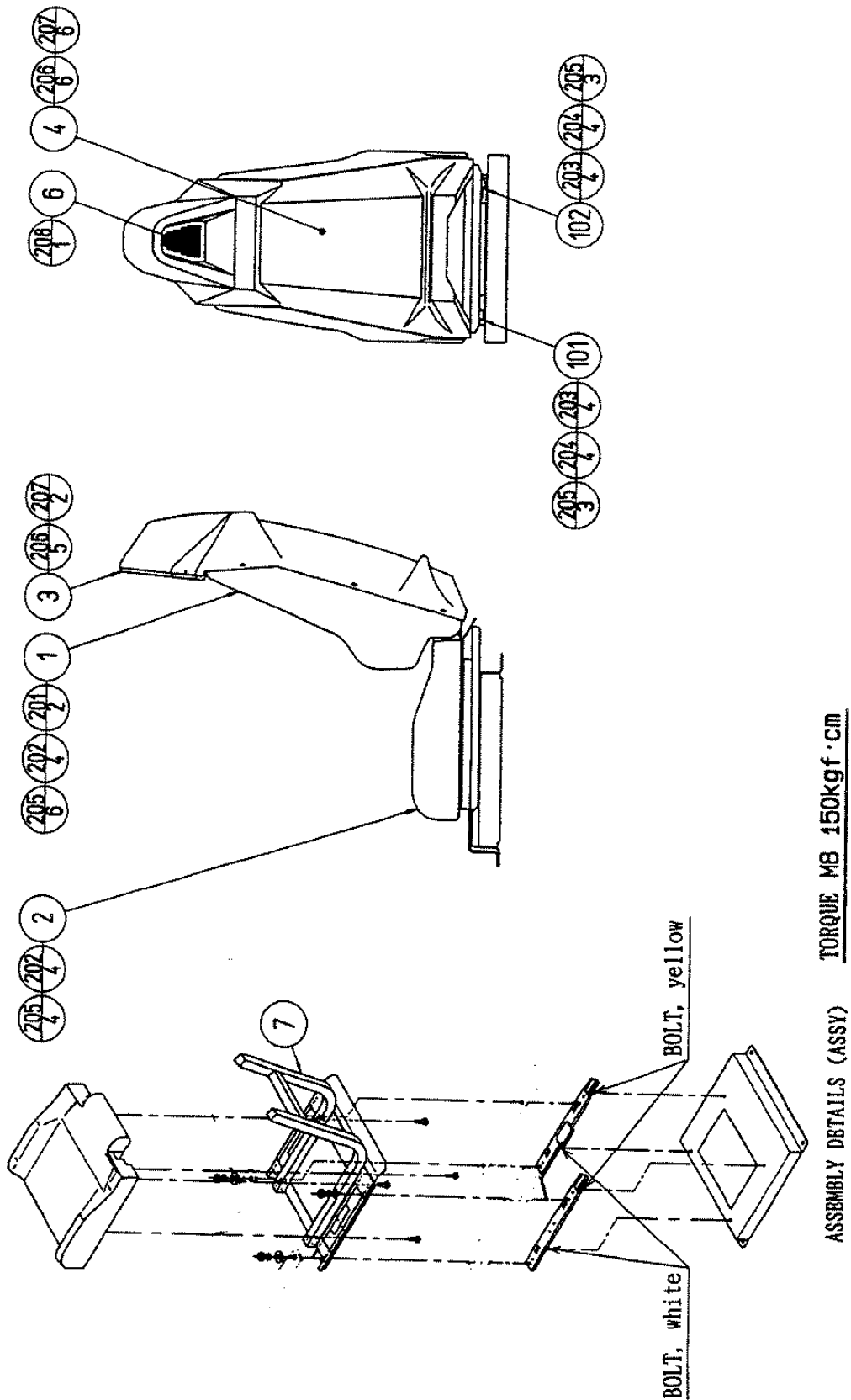
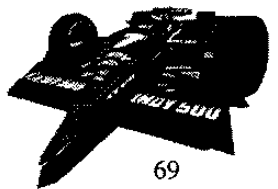

FIGURE 20-13: SEAT ASSEMBLY



SEAT ASSEMBLY P/N: INY0-1600

Table 20-12: Seat Parts List

<u>NO.</u>	<u>PART NO.</u>	<u>DESCRIPTION</u>
1	INY0-1601	UPPER SEAR
2	INY0-1602	LOWER SEAT
3	INY0-1603	SEAT BACK COVER F
4	INY0-1604	SEAT BACK COVER R
6	INY0-1606	SEAT FRAME BRKT
7	RALO-2081	SEAT FRAME TWIN
10	INY0-1605	SEAT BASE
101	999-0443	SEAT RAIL SET
201	030-000845-S	HEX BLT W/S M8X45
202	030-000850-SB	HEX BLT W/S BLK M8X50
203	050-H00800-0B	HEX NUT BLK M8
204	060-S00800-0B	SPR WSHR BLK M8
205	060-F00800-0B	FLT WSHR BLK M8
206	000-T00412-0C	M SCR TH CRM M4X12
207	068-441616-0C	FLT WSHR CRM 4.4-16X16
208	000-P00412-W	M SCR PH W/FS M4X12

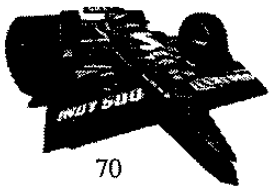

ELECTRICAL ASSEMBLY P/N: INY1-4000

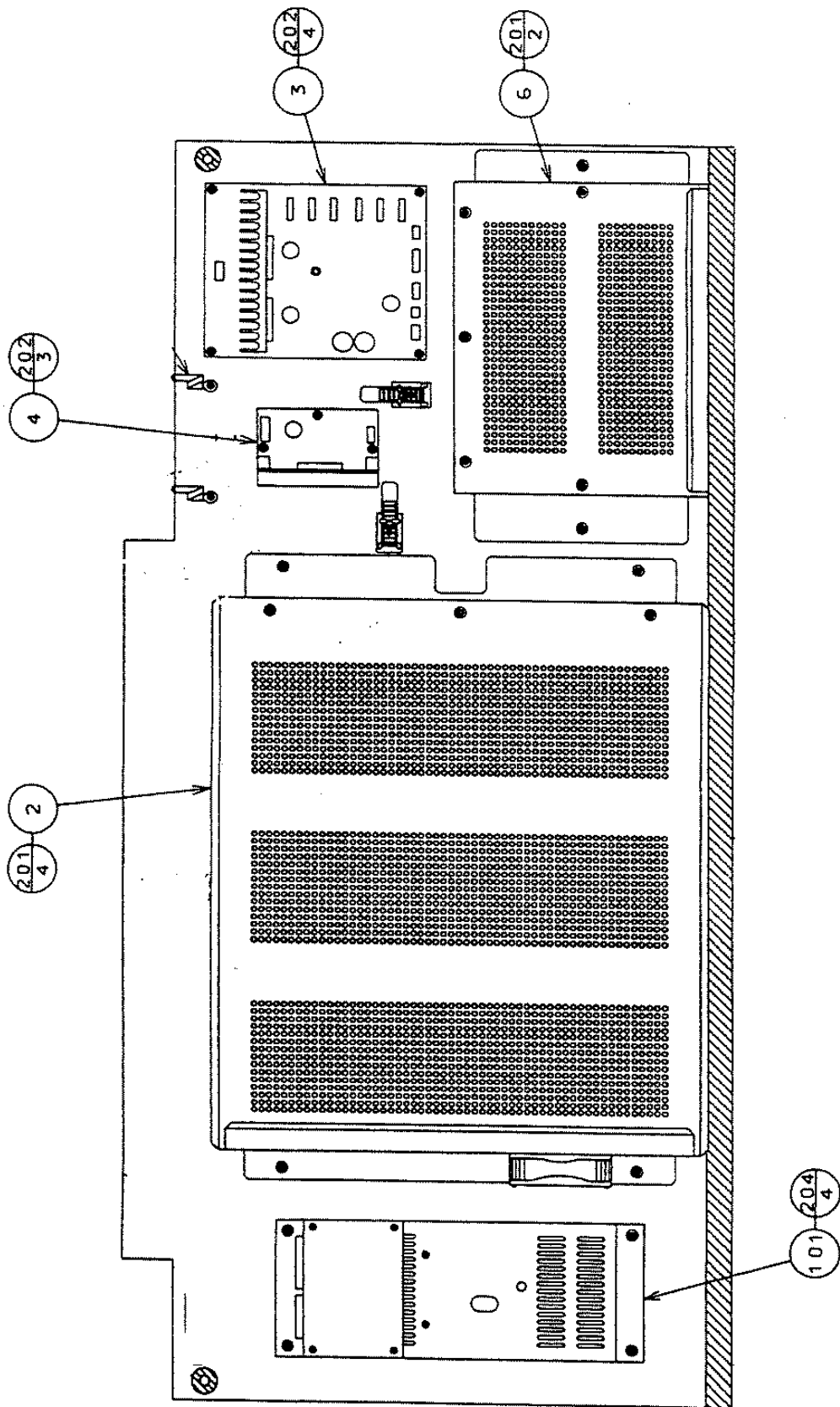
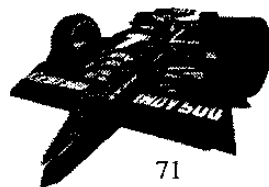

FIGURE 20-14: ELECTRICAL ASSEMBLY



ELECTRICAL ASSEMBLY P/N: INY1-4000

Table 20-13: Electrical Assembly Parts List

<u>NO.</u>	<u>PART NO.</u>	<u>DESCRIPTION</u>
2	INY0-4300	ASSY SHIELD CASE
3	838-11650-05	EQ. PWR AMP INY
4	838-11651	LOWPASS AMP
6	INY0-4600	ASSY DRIVE CONTROL BD
101	999-0102	150W SWITCHING XT
	5601-5260	PWR XFMR 12.5V 6A/100V 6.5A

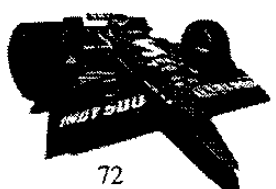

MOTOR DRIVE BOARD ASSEMBLY P/N:

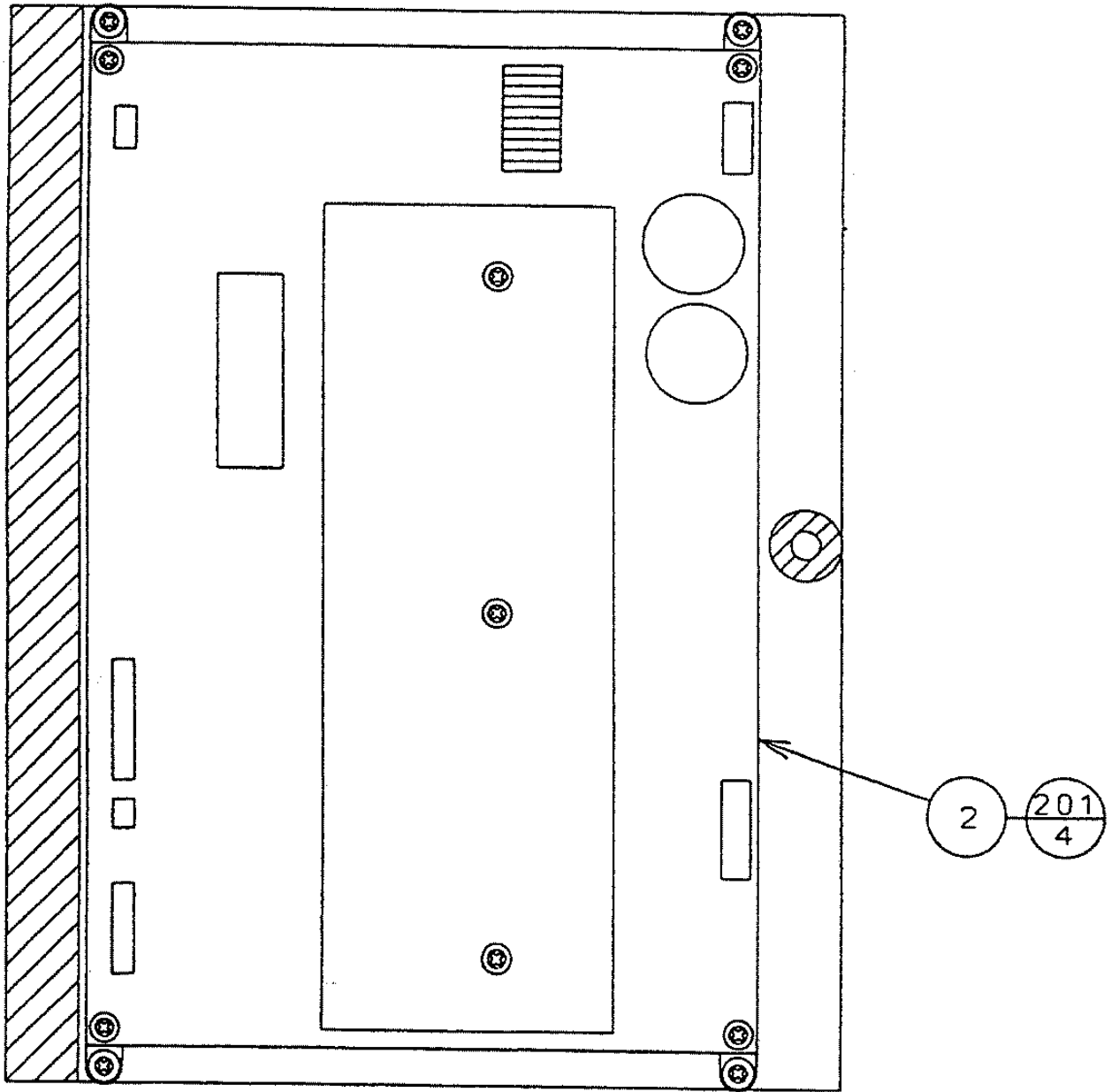
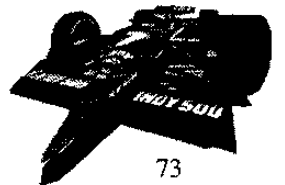

FIGURE 20-16: MOTOR DRIVE BOARD ASSEMBLY

Table 20-15: Motor Drive Board Parts list

<u>NO.</u>	<u>PART NO.</u>	<u>DESCRIPTION</u>
2	838-11966	MOTOR DRIVE BOARD



SHIELD CASE ASSEMBLY P/N:

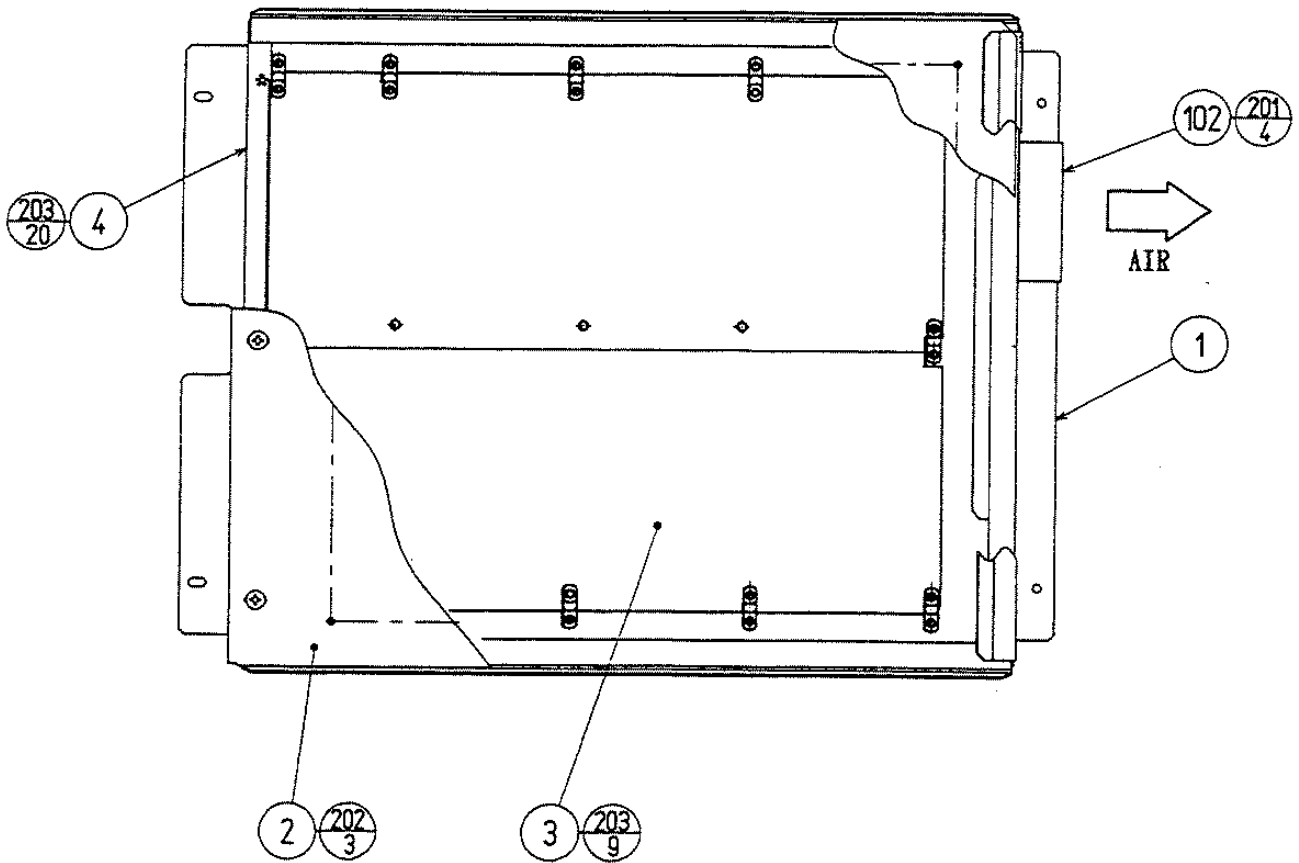
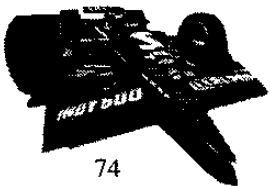

FIGURE 20-17: SHIELD CASE ASSEMBLY

Table 20-16: Shield Case Parts List

<u>NO.</u>	<u>PART NO.</u>	<u>DESCRIPTION</u>
1	1050-5218	SHIELD CASE
2	1050-5219	SHIELD CASE LID
3	833-11992	GAME BD INDY 500
4	839-0818	FLT BD B-CRX INY
102	2601-0055	FAN MOTOR DC5V



DRIVE CONTROL ASSEMBLY P/N: INY0-4600

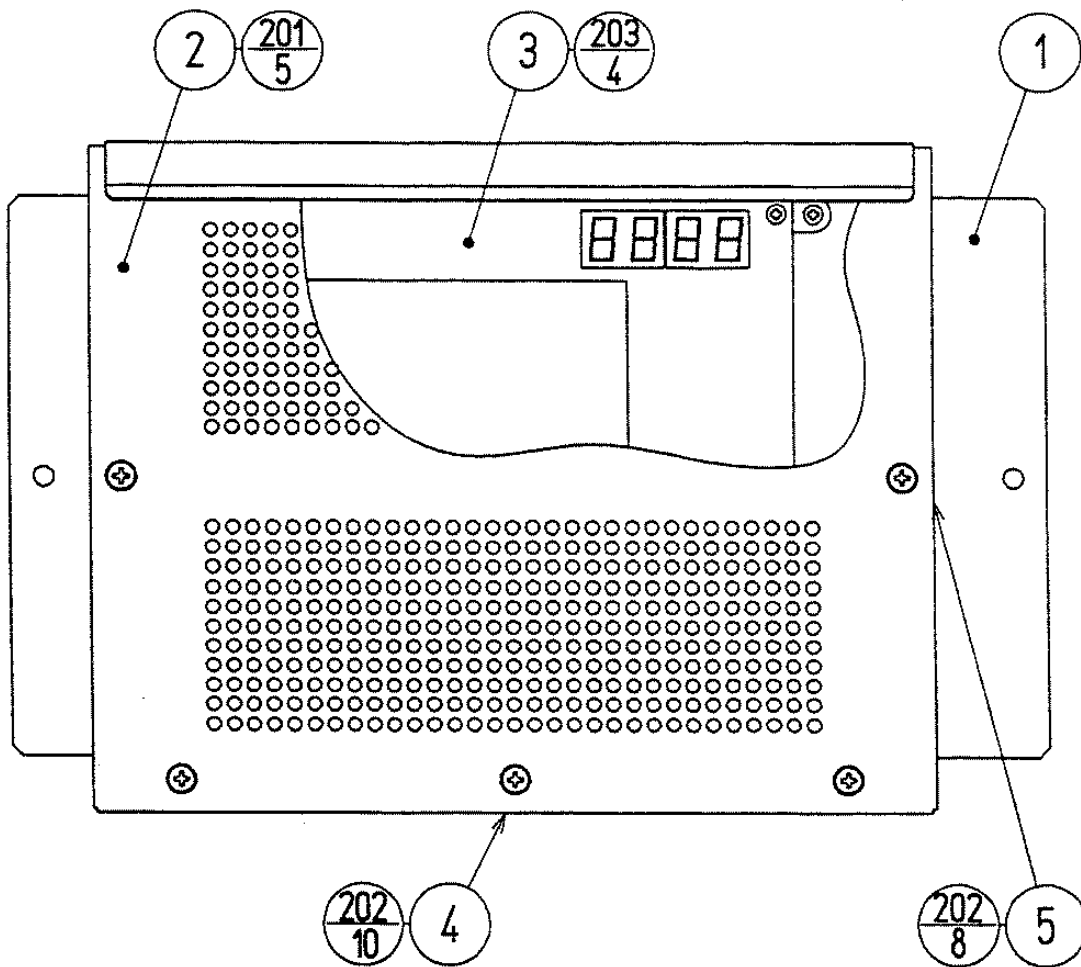
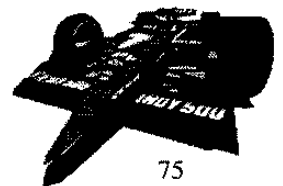
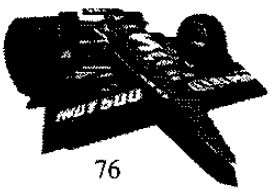

FIGURE 20-18: DRIVE CONTROL ASSEMBLY

Table 20-17: Drive Control Parts List

<u>NO.</u>	<u>PART NO.</u>	<u>DESCRIPTION</u>
1	INY0-4601	SHIELD CASE
2	INY0-4602	SHIELD CASE LID
3	838-11967	DRIVE CONTROL BD
4	839-0829	FLT BD DRIVE CONTROL BD A
5	839-0830	FLT BD DRIVE CONTROL BD B





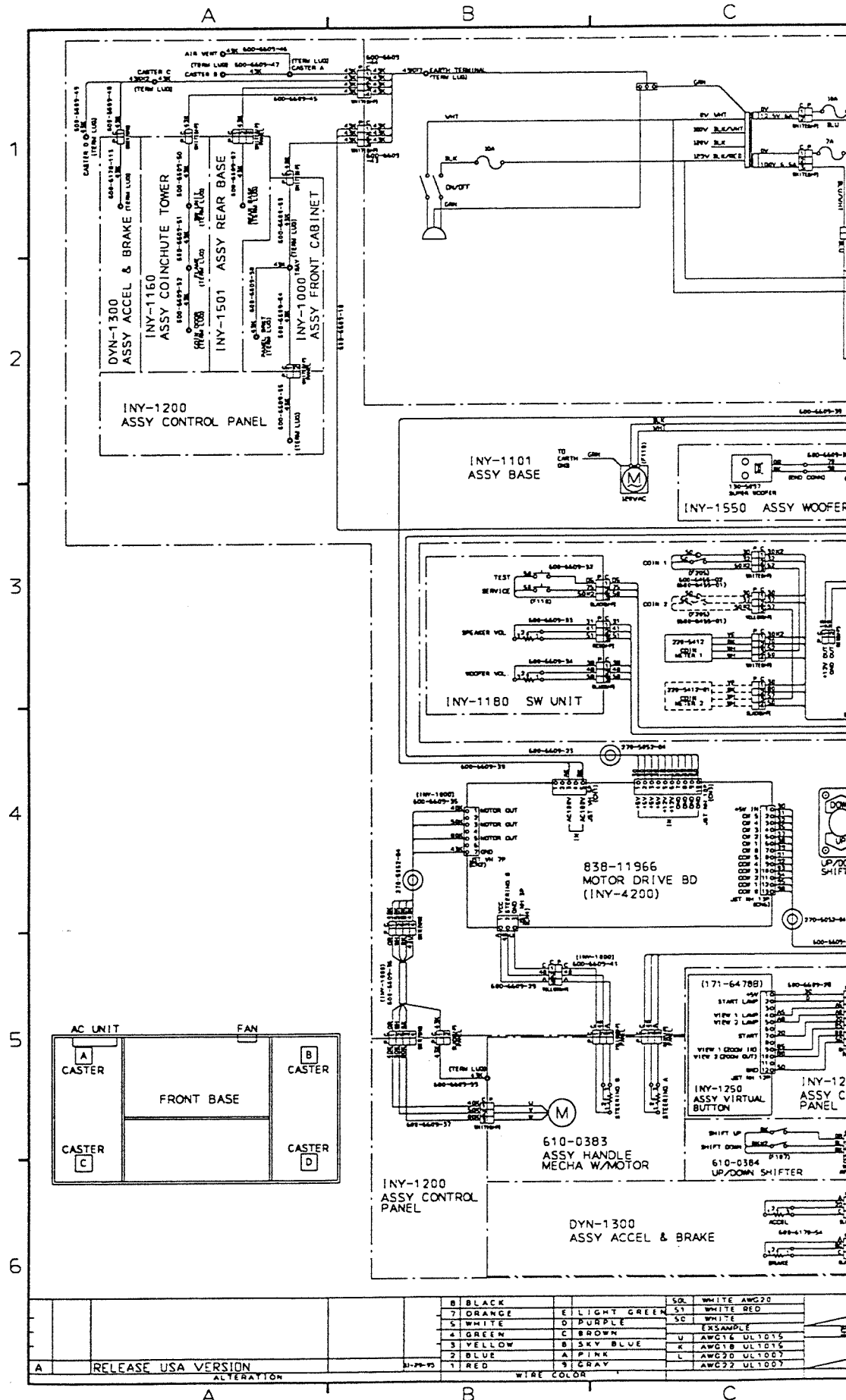

RELEASE USA VERSION
ALTERATION

8	BLACK	E	LIGHT GREEN	SOL	WHITE AWG20
7	ORANGE	D	PURPLE	51	WHITE RED
5	WHITE	C	BROWN	SC	WHITE
4	GREEN	B	SKY BLUE		EXSAMPLE
3	YELLOW	A	PINK	U	AWG16 UL1015
2	BLUE	1	RED	K	AWG18 UL1015
1	RED			L	AWG20 UL1007
					AWG22 UL1007

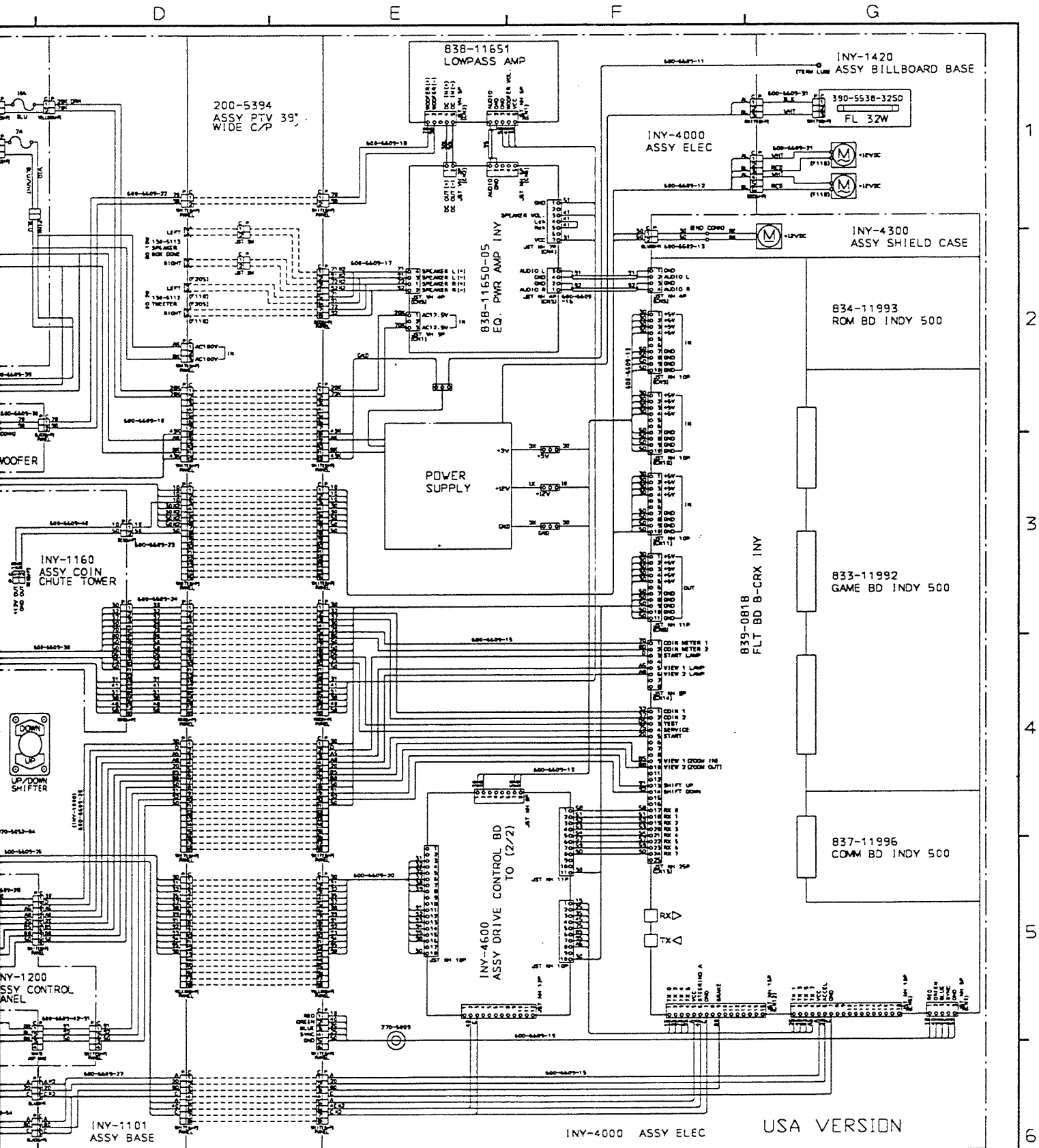

120V	200V	220V	240V	100V 50/60Hz
507W		519W	525W	458W

SEGA SEGA ENTERPRISES, LTD. THIS DRAWING WILL IN NO WAY BE COPIED. 許可なく複写
 TO BE RETURNED ON DEMAND. 複製等厳禁

SEGA INDY 500 DX 1173 (1/2)

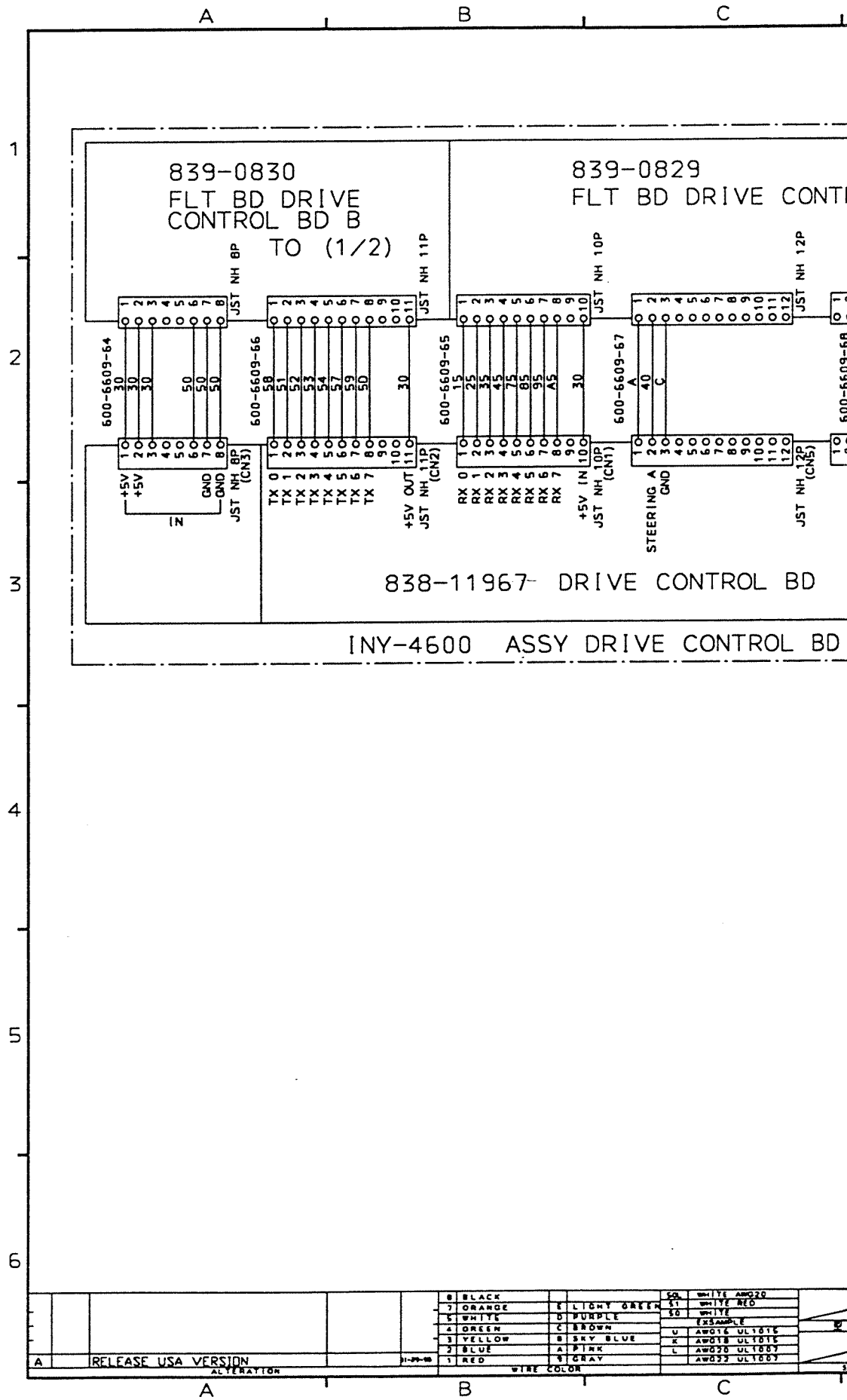

1
2
3
4
5
6

RELEASE USA VERSION
 ALTERATION

WIRE COLOR

A B C

D

E

F

G

CONTROL BD A
TO (1/2)

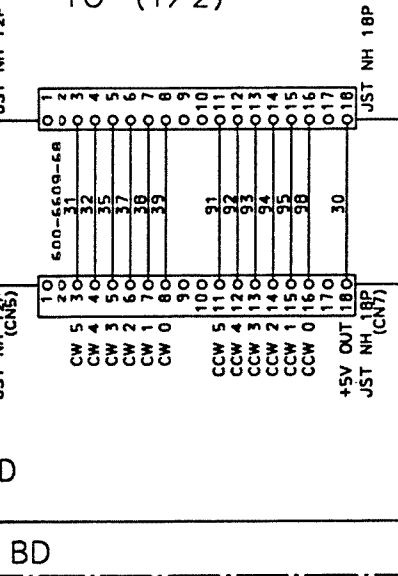

1

2

3

4

5

6

USA VERSION

	120V	200V	220V	240V	100V 50Hz/60Hz
	507W		519W	525W	458W
型式記号番号	設計	製図	検図	承認	
SUB-ASS'Y					

SEGA SEGA ENTERPRISES, LTD. THIS DRAWING WILL IN NO WAY BE COPIED. 許可なく複写 複製等厳禁 TO BE RETURNED ON DEMAND.	SEGA INDY 500 DX	1173 (2/2)
	DESCRIPTION	DIAGRAM No.

D

E

F

G

22. INDY 500 DELUXE MANUAL COMMENTS

SEGA has made every effort to ensure that this manual is accurate. If you find any errors or omissions, or have other comments on the **Indy 500 Deluxe** manual, please write them below, detach, and deliver this page by FAX or mail to:

SEGA ENTERPRISES INC. (USA)
ATTN: Engineering Dept.
45133 Industrial Drive
Fremont, CA 94538 USA
FAX: (415) 802-1754

Comments: _____

Optional Identification Information:

Name: _____
Company: _____
Address: _____
City, State, Zip: _____
Phone: _____
FAX: _____

