

# **namco**

# **ALPINE RACER™**

## **52"**



## **Operators Manual**

IT IS THE RESPONSIBILITY OF THE OPERATOR TO MAINTAIN CUSTOMER SAFETY AT ALL TIMES, AND IT IS IMPERATIVE THAT THE DETAILS SET OUT IN THIS MANUAL ARE FOLLOWED PRECISELY,

© 1994 **NAMCO LIMITED** all rights reserved.

No part of this publication may be reproduced by any mechanical, photographic or electronic process, or in the form of phonographic recording, nor may it be stored in a retrieval system, transmitted or otherwise copied for public or private use, without permission from  
**NAMCO EUROPE LIMITED**

While the information contained in this manual is given in good faith and was accurate at the time of publication, NAMCO EUROPE LTD. reserve the right to make changes and alterations without notice.

This machine has been manufactured in accordance with European Community directives (1st. January 1996), and as such bears the **CE** marking. Any changes or modifications to this machine must be in accordance with European Community directives (1st. January 1996).

If you make any unauthorised changes to this product, you may contravene European Community directives (1st. January 1996)

Published by:  
**NAMCO EUROPE LIMITED**  
Namco House,  
8 Acton Park Estate,  
The Vale,  
London. W3 7QE

Phone:- 0208-324-6000  
Fax:- 0208-324-6010

# SAFETY WARNING

In order to use this machine safely, be sure to read this Operators Manual carefully before installation, adjustment or use of this machine.

Whenever the owner of this machine entrusts disassembly, installation, adjustment, routine maintenance or trouble shooting to another person, the owner should ensure that that person read the appropriate precautions and relevant sections of this manual before starting work.

**In order that no accidents occur when the machine is in operation, strictly follow the notes on safety described below. Also, carefully read [section 2](#), "Precautions"**

## Warnings for Operation (Ⓢ Requirements)

- NOTE:** Only operate this machine after checking that it has been installed correctly and in accordance with the installation and commissioning manual.
- NOTE:** Parts of this machine move during game play, so there are places where the distance between the stationary section and moveable section changes. There are warning notices to keep hands and feet clear of moving parts, however if the operator feels that a person is in any danger, he should warn that person accordingly.
- NOTE:** The warning notices must always be kept in good condition and replaced if worn, so that the customer can read it clearly.
- NOTE:** **If there is an error or problem with this machine, operation must be stopped immediately and the problem rectified before further use.**

## Warnings for Disassembly, Installation, Routine Maintenance, and Troubleshooting.

- DANGER:** Namco Ltd. bears absolutely no responsibility for accidents or injuries resulting from unauthorized changes to this machine.
- DANGER:** Ensure that the machine has been turned **OFF** before making adjustments or carrying out maintenance. Also ensure only qualified personnel carry out maintenance or turn the power **ON** to this machine.
- DANGER:** The power supply and inside the monitor will remain hot and have areas of high voltage even though the machine has been turned OFF, and there is a possibility of burns or electric shock. Be careful not to touch these areas.
- DANGER:** In order to avoid injuries due to mis-operation, be sure that the voltage of the main power supply is within the prescribed limits. Also to prevent possible electric shocks due to failure, this machine **MUST** be fitted with a securely connected earthed plug.
- NOTE:** Do not turn the power switch **ON** until the machine has been installed correctly.

# 1. SPECIFICATIONS

<b>POWER SUPPLY :-</b>	230volts AC
<b>MONITOR :-</b>	Thomson 52" Projector Monitor (RP52)
<b>COIN ACCEPTOR</b>	Mars CashFlow - 1 Channel

**DIMENSIONS :-**

Assembled	1265(w) x 2245(d) x 2320(h)
Monitor Cabinet	1250(w) x 645(d) x 1940(h)
Ski Assembly	1265(w) x 1600(d) x 1220(h)
Header	1145(w) x 350(d) x 380(h)

**WEIGHT :-**

Assembled	458kg
Monitor Cabinet	200kg
Ski Assembly	240kg
Header	18kg

**ACCESSORIES :-**

Keys:	(Cash Door) .....	2
	(Coin Door) .....	2
	(Service Door) .....	2
	IEC Mains Lead .....	1
	Operators Manual .....	1
	Installation Manual .....	1
	Monitor Manual .....	1
	Monitor Remote Control W/Batteries .....	1
	Cashflow Data .....	1
	Floor Safety Mat & Decal .....	1
	Floor Safety Mat Securing Plate .....	2
	Floor Safety Mat Support Bracket .....	2
	Joint Bracket - LHS .....	1
	Joint Bracket - RHS .....	1
	Potentiometer .....	1
	M10x35 Hex Head Set Screw - S/Steel .....	8
	M10 Flat Washer - S/Steel .....	8
	M10 Spring Washer - S/Steel .....	8
	M8x20 Hex Head Set Screw - S/Steel .....	4
	M8 Flat Washer - S/Steel .....	4
	M8 Spring Washer - S/Steel .....	4
	M6 Dome Head Nut - Chrome .....	6
	M6X25 Hex Head Screw - BZP .....	2
	M6 Flat Washer H/Duty - BZP .....	2
	M6 Spring Washer - BZP .....	2
	M4 Security Wrench .....	1
	M5 Security Wrench .....	1
	M6 Security Wrench .....	1

## 2. PRECAUTIONS

**Be sure to read this section carefully.**

### 2-1 Notes on Operation (C Requirements)

- NOTE:** Only operate this machine after checking that it has been installed correctly and in accordance with the Installation and Commissioning Manual.
- NOTE:** Parts of this machine move during game play, so there are places where the distance between the stationary section and moveable section changes.
- NOTE:** There is a warning sticker that the player must be wearing flat shoes, unsuitable footwear e.g. high heel shoes could cause the player to lose balance and fall. However if the operator feels that a customer playing the game is in any danger, he should warn the customer accordingly.
- NOTE:** The warning sticker must always be kept in good condition so that the customer can read it clearly, and be replaced if worn.
- NOTE:** Ensure customer safety at all times. Be especially careful in the case of young children, who should be supervised by an adult at all times.
- NOTE:** **If there is an error or problem with this machine, operation must be stopped immediately.**
- NOTE:** Service, adjustments and routine maintenance should be carried out by qualified personnel only.

Parts of this machine swing to the left and right during game play. In **order to maintain the customer's safety**, the operator should strictly follow the appropriate precautions.

### 2-2 Safety Mechanisms and Controls

For safety, this machine is equipped with a locking mechanism for securing the steps when the machine is not being played.

- The step locking mechanism is controlled as describe below.
  - a. After selecting the course, the step lock is released before game start.
  - b. At game over, the steps are locked.
  - c. If the steps are moved left or right while they are locking or unlocking, the motor temporarily stops in order to prevent damage to the step-lock motor. When the steps are no longer being moved left or right, the motor will restart. To prevent damage from occurring, do not move the steps while the motor is running.
  - d. When the machine is first turned ON, the step-lock mechanism is checked automatically by unlocking and re-locking the steps.
  - e. If the step-locking system fails, an error message will be displayed on the monitor screen.  
[Refer to section 6-4-3 "Handling Motor Errors"](#) and section 8 "Trouble Shooting".

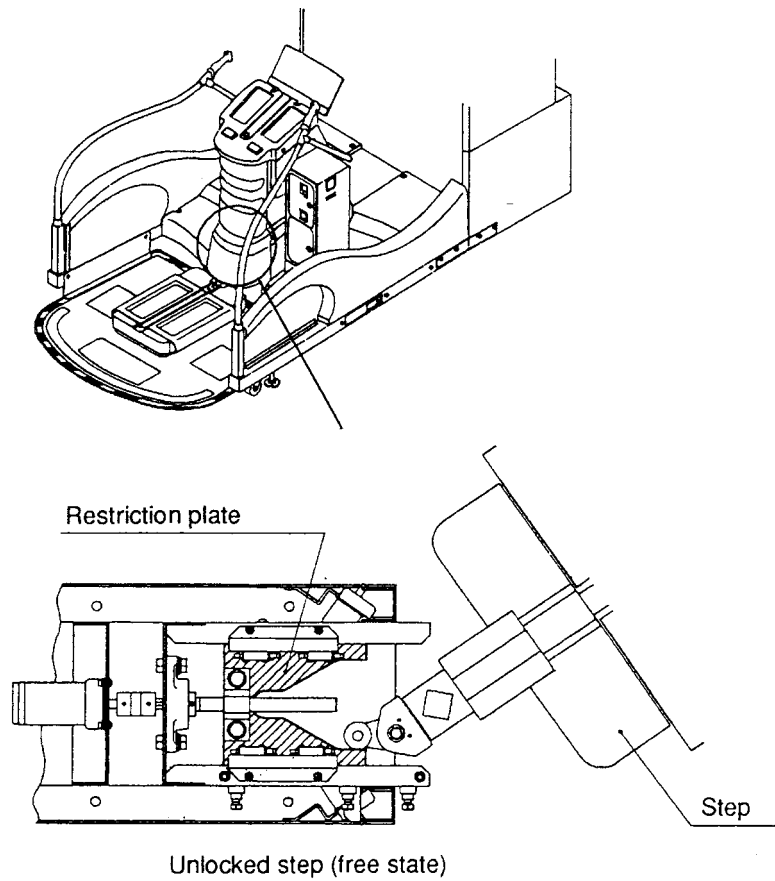

The restriction plate moves to the side of the steps and locks the steps.

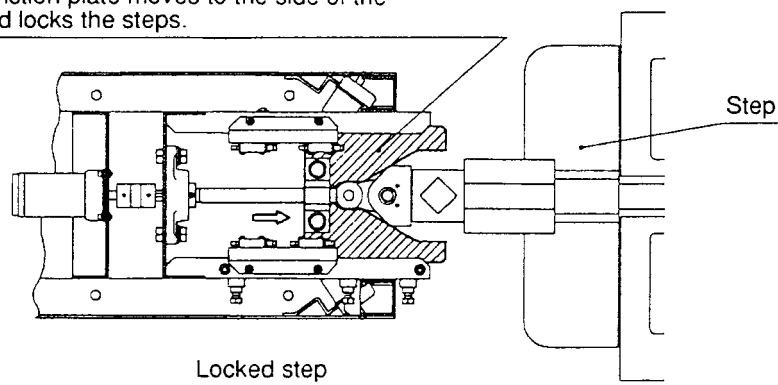

### 2-3 Cautions When Transporting.

- a. Do not subject the game to physical shock when transporting or moving it.
- b. Always return the levellers to the UP position before moving the machine, even for short distances.
- c. The monitor cabinet, ski assy and header assy **must** be separated before shipping.
- d. Take care not to rope any moulded (plastic) parts when transporting.
- e. Always ship the monitor section upright.

**THIS MACHINE IS NOT DESIGNED TO BE MOVED BY FORK LIFT. DO NOT USE**

## 2-4 Cautions When Installing.

1. This machine is designed for indoor use only. **Do Not** install the machine in the following places

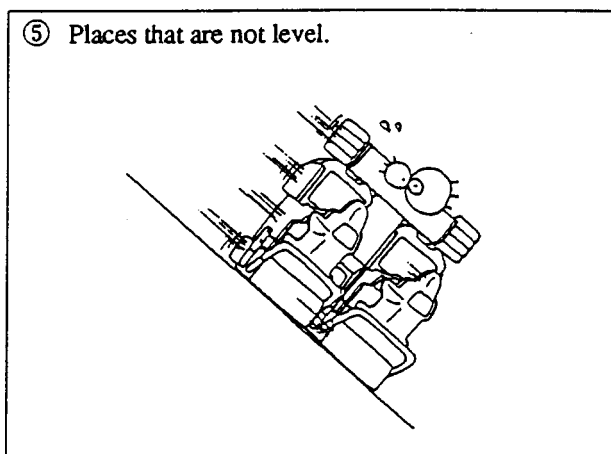
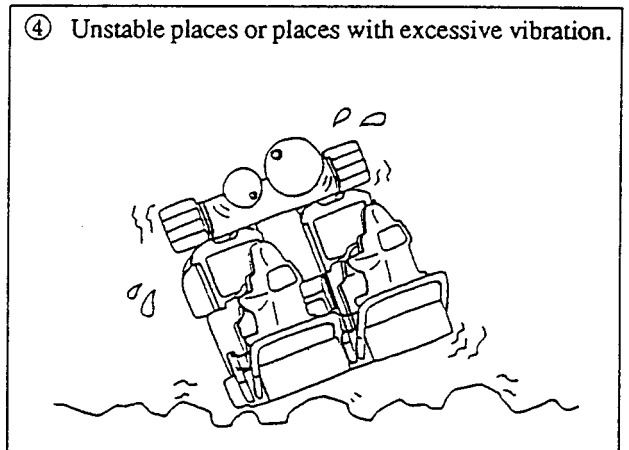
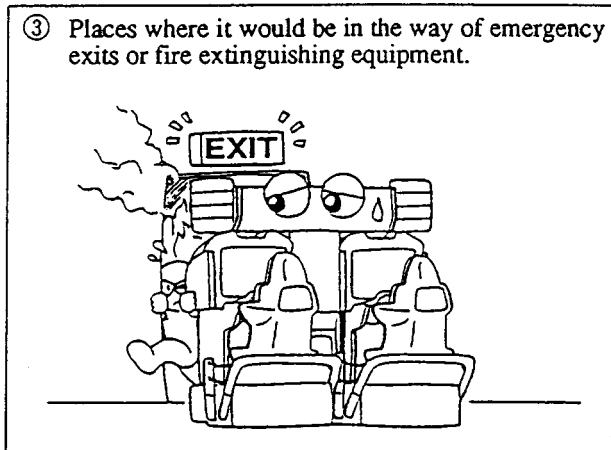
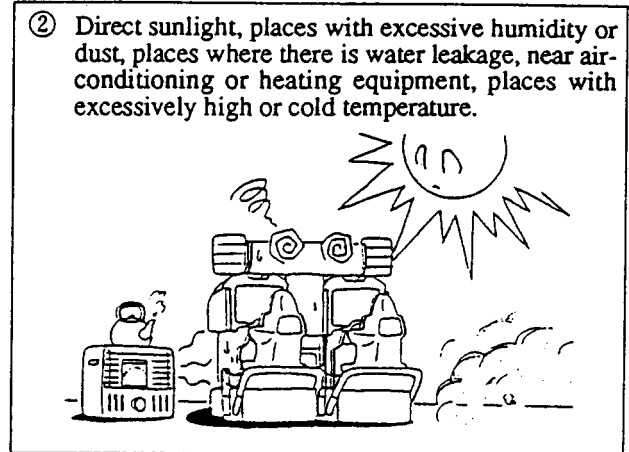
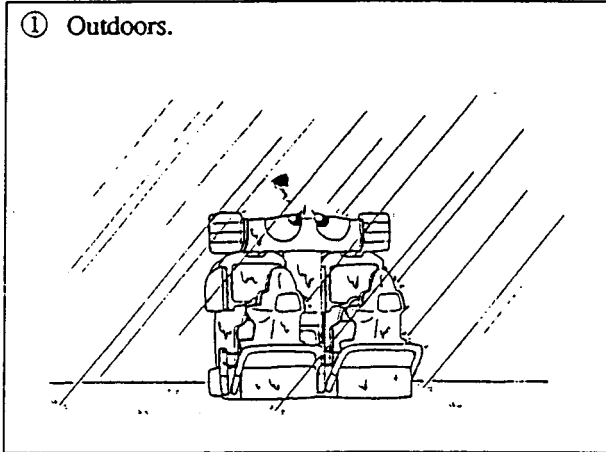

2. If this machine is installed next to walls or other machines, ensure that there is plenty of space between them.

**NOTE:** So that customers are not injured by the movement of the Ski Tray, ensure that there is at least 300mm separation between other machines or walls. If two Alpine Racer machines are next to each other the space between them must be at least 600mm.

**NOTE:** In order to gain access to the Power Supply and CPU assemblies, make sure that the rear of the machine is separated from a wall or other machine by at least 500mm.

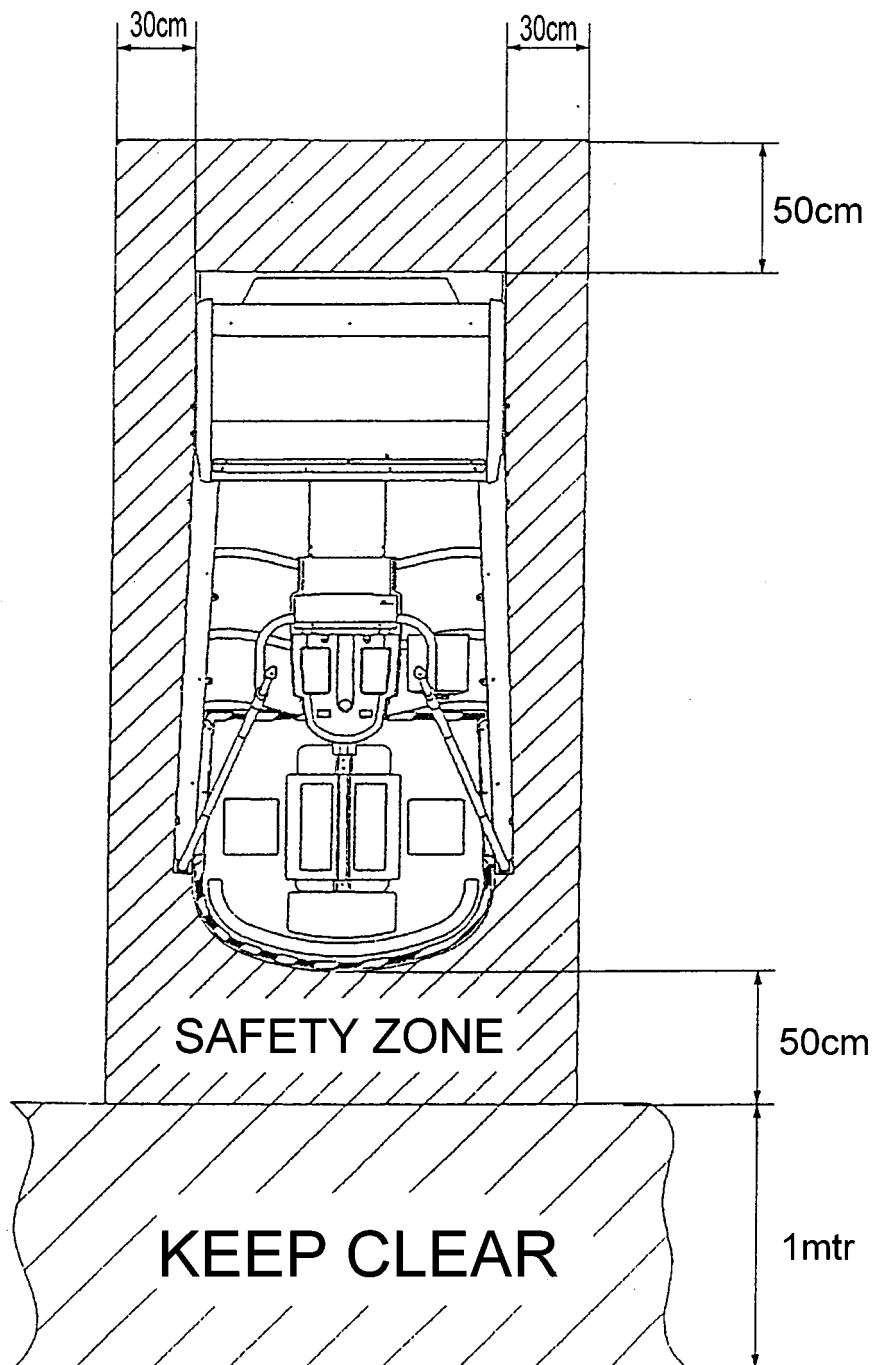



### 3. HOW TO PLAY

This game is based on Alpine ski racing.

The player stands on the steps and moves them left or right to control the skier. By using the inner edge when moving the steps, the skier slows down and turns quickly.

- **Race Mode**  
The player races the computer skiers and the object is to cross the goal line first. The game is over when the player crosses the finish line within the given time period, or the time period reaches zero. The time period is increased each time a player passes a check point.  
If a player wins in a fast time they can enter their initials. Select letters using the select buttons and enter them by using the decision (Viewpoint) button.
- **Time-Trial Mode**  
The object of the game is to pass between the flags (gates) and to cross the finish line in the fastest time. The rules require the player to go through the gates, so more technique is needed for this mode than the normal race mode.  
The game is over when the player crosses the finish line within the given time period, or the time period reaches zero. The time period is increased by one second each time a player passes through a gate.  
If a player completes a course in a fast time they can enter their initials. Select letters using the select buttons and enter them by using the decision (Viewpoint) button.  
A player is not disqualified for not passing through a gate, however the player will not be able to enter their initials even if they cross the finish line in a good time.
- **Game Mode Selection**  
After inserting sufficient credit, the "Game Mode Selection" screen is displayed. The player selects either the "Race Mode" or "Time-Trial Mode" by using the L/R selection buttons, and pressing the decision (Viewpoint) button.
- **Course Selection**  
After the game mode has been selected, the "Course Selection" screen is displayed.  
The player can select one of three courses, "Novice", "Intermediate" and "Expert".
- **Viewpoint Selection**  
The viewpoint button can be pressed at any time during a game to switch between the player's view and behind view.

**Players View:** This is the view as seen by the skier. This provides an exciting view while skiing. The race mode starts in this view.

**Behind View:** This is the view from behind the skier. This view can be used to get an understanding of the skier's posture and surrounding conditions. The time trial mode starts in this position.

## 4. MAJOR COMPONENTS

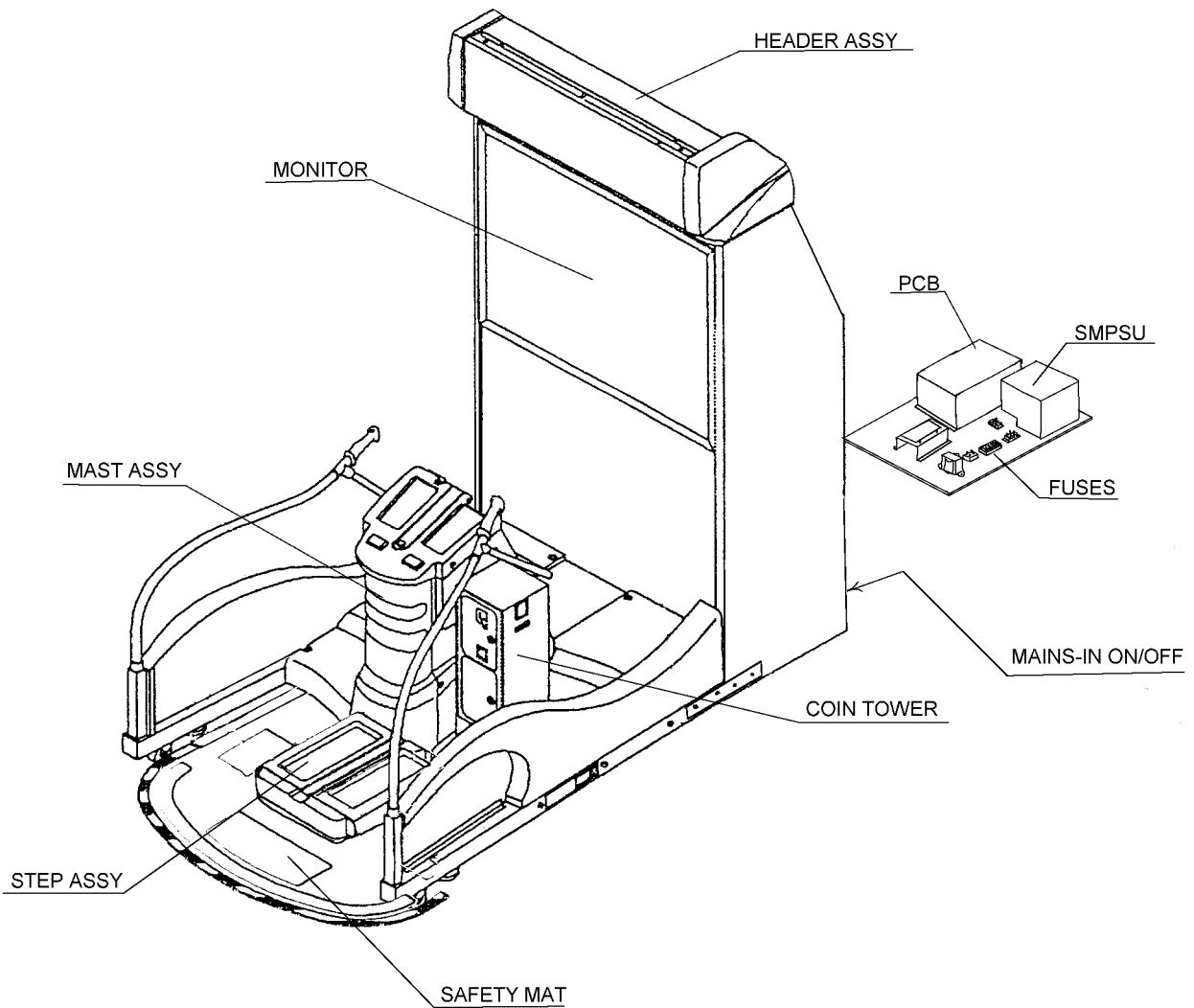

## 5. INSTALLATION

**WARNING** If the location site of this machine has a polished floor it is recommended that rubber pads are fitted under the level adjusters to prevent the machine sliding on the floor.

### 5-1 Fitting the Header Assembly

**The Header Assembly has a forward centre of gravity, so it is important that at least two people are used to fit or remove the Header Assembly.**

The fitting position of the Header Assembly is very high, and it is important that a means of reaching the height safely, without stretching, is available. (e.g. steps, step stools etc.)

1. Place the Header Assembly on to the monitor cabinet, connect the connectors and pass the connectors in to the cabinet, slide the header back ensuring that it engages fully in to the retaining brackets at the front of the monitor cabinet.
2. Fit the 2 off M6x25 Hex Head Screws, Spring and Flat washers to retain the Header Assembly to the cabinet.

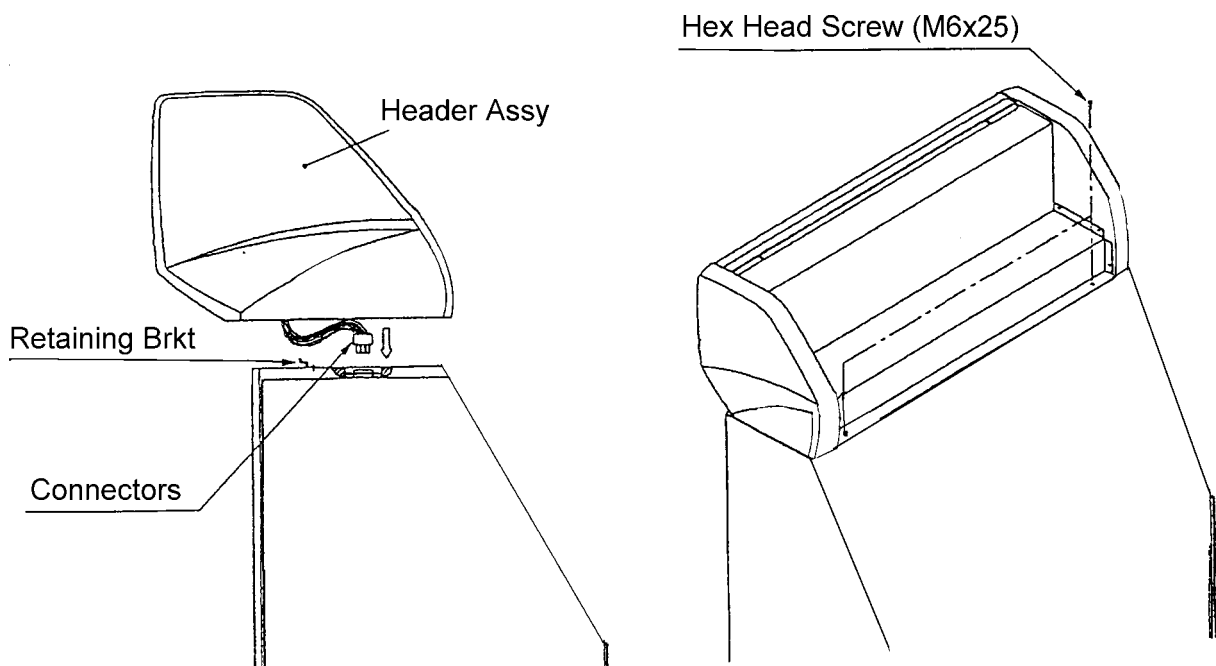

## 5-2 Connecting the Ski Assy to the Monitor Cabinet.

1. Connect the connectors between the Ski Assembly and Monitor Cabinet.
2. Push the Ski Assembly fully up to the monitor cabinet, taking care not to trap any wires.
3. Fit, finger tight, a joint bracket to each side using 4off Hex Head Set Screws (M10x25), Spring and Flat Washers on each bracket. Tighten fully all screws. *(Note: Joint Brackets are handed, ensure bracket is fitted with fixing holes uppermost.)*

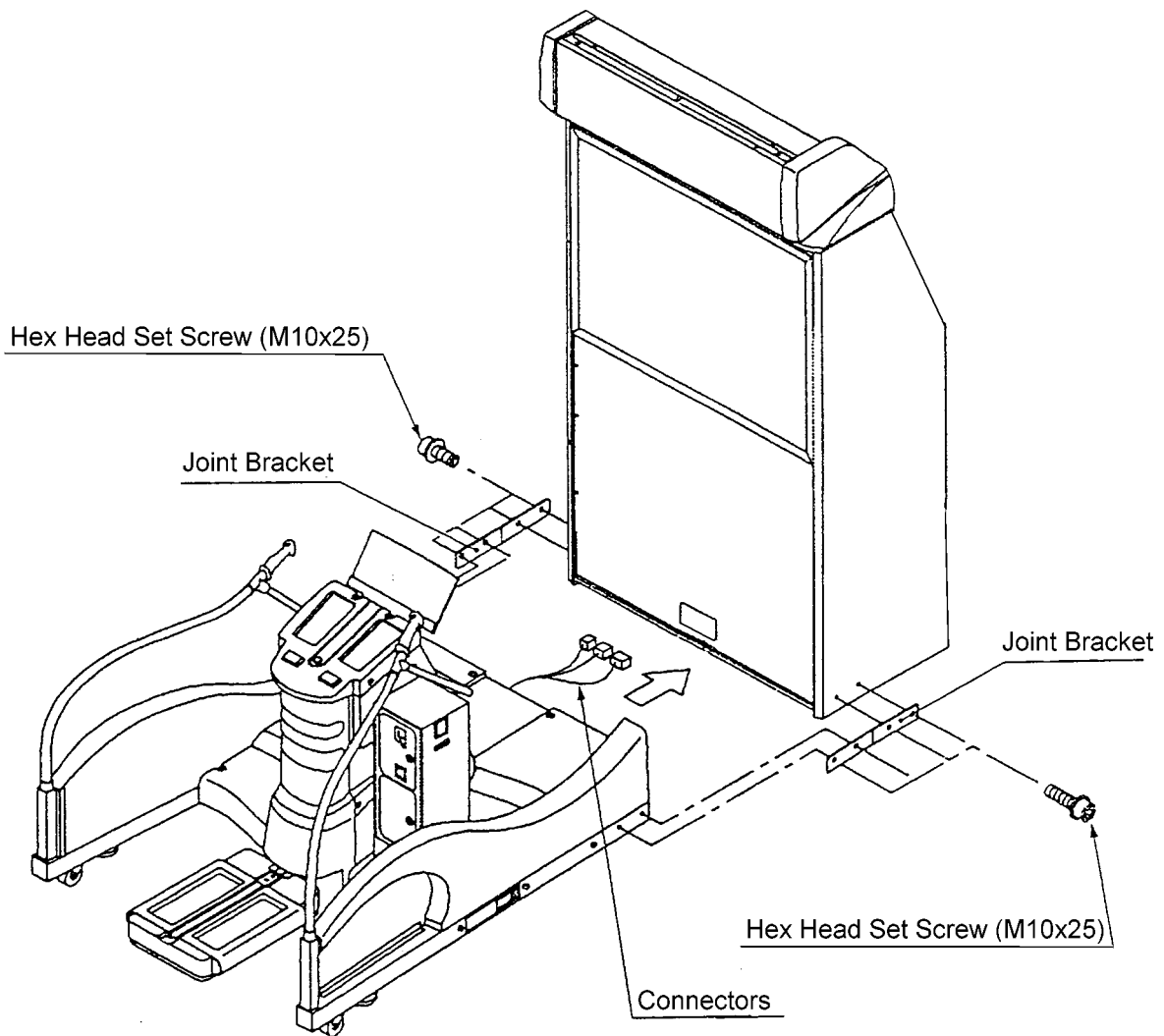

**NOTE:-**

When the machine is fully assembled and in its final position, lower the 10 level adjusters, (4 on the monitor cabinet and 6 on the ski assy), with a spanner so that all castors are raised from the floor by approximately 5mm, and the machine is level. Tighten the lock nuts with a spanner to ensure that the level adjusters do not move.



If this machine is installed on a smooth or shiny floor, it is recommended that rubber slip mats be placed under each adjustable foot to prevent the machine from moving when being played.

### 5-3 Fitting the Safety Mat

1. Assemble the Floor Safety Mat by fitting the securing plates from underneath, the support brackets from the top and retaining the assembly together with the M6 Dome Nuts.

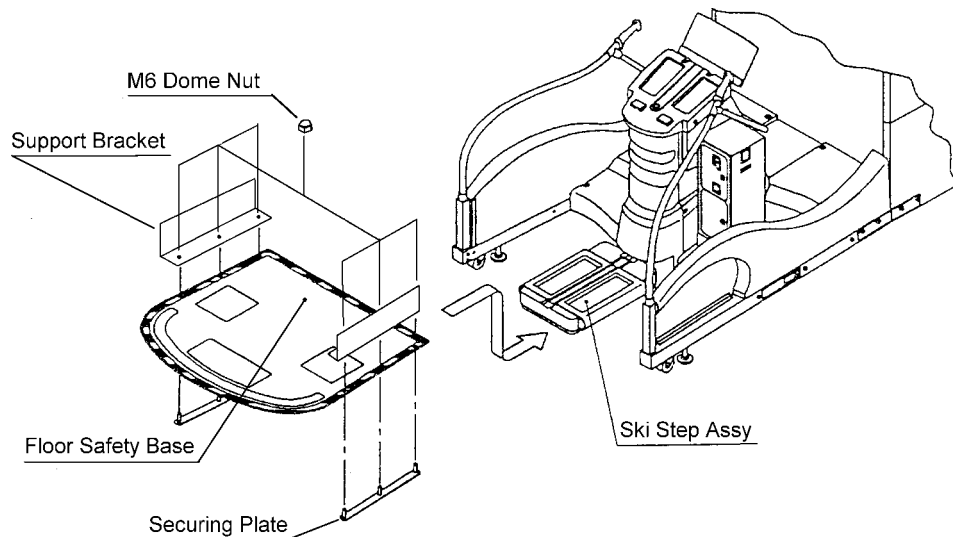

2. Place the assembled Safety Mat into position under the Ski Step Assy.
3. Retain the Safety Mat in position with the Hex Head Set Screws (M8x20), Spring Washers and Flat Washers

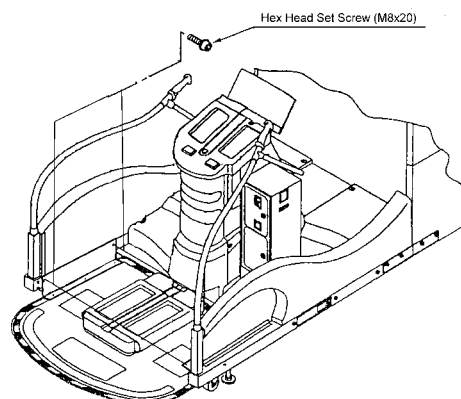

## 6. ADJUSTMENTS

### 6-1 Turning on the Power

After the machine has been installed, turn ON the power. The power switch is located on the rear of the monitor cabinet.

### 6-2 Adjustment Switches

The Adjustment switches are located inside the coin door.

1. Service Switch.  
Press this switch to obtain game credits without incrementing the play meter.
2. Test Switch  
Slide the test switch ON to enter test mode.  
Test mode allows testing and the changing of game settings. (Refer to section [6-3 "Test Mode" \(page 12\)](#))

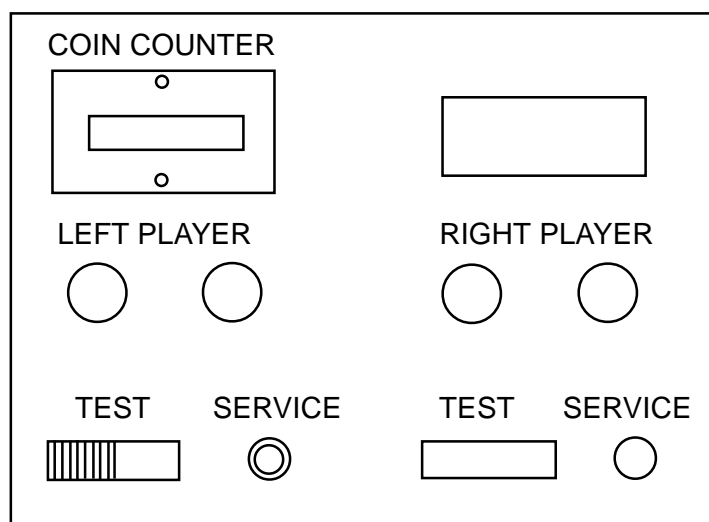

Service Bracket

### 6-3 Test Mode

1. Open the coin door and slide the test switch "ON". The menu screen will be displayed on the monitor.
2. Select the test required by pressing the 'Left or Right Selection' push button. The selected test will 'blink'.
3. Enter the selected test by pressing the 'Decision' push button. Select "EXIT" to return the "Menu Screen".
4. After testing is completed, ensure that the test switch is returned to the "OFF" position to return to normal game mode.

*The Test Switch must always be in the "OFF" position for normal game mode.*

MENU	
COIN OPTIONS	(1) Sets the price of play ( <a href="#">See 6-3-1</a> )
GAME OPTIONS	(2) Sets the game options ( <a href="#">See 6-3-2</a> )
I/O TEST	(3) Used for testing switches and controls ( <a href="#">See 6-3-3</a> )
SOUND TEST	(4) Used for testing sound and setting volumes ( <a href="#">See 6-3-4</a> )
MONITOR TEST	(5) Used for adjusting the monitor
ADS TEST	(6) Displays accumulated game data
OTHERS	(7) Used for testing the PC Boards and for initializing all of the settings
L/R SELECTION BUTTON : CHOOSE	
DECISION BUTTON : ENTER	

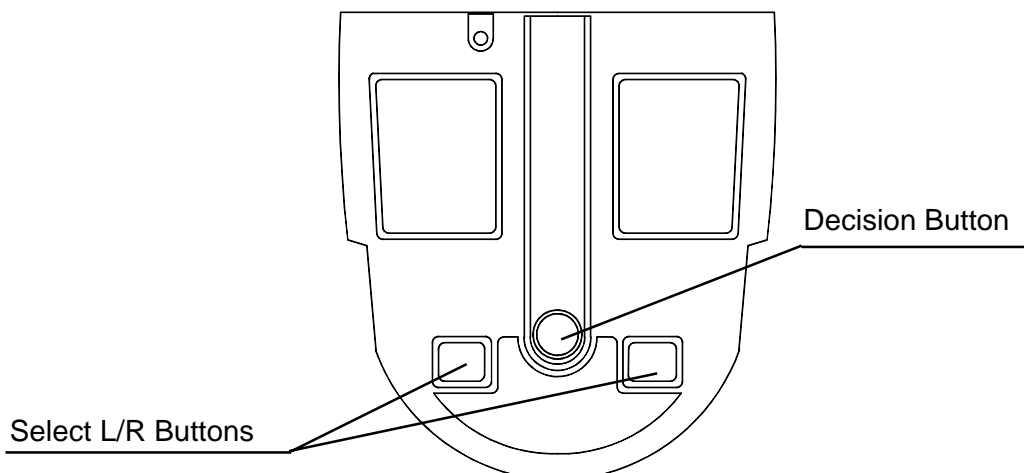

### 6-3-1 Coin Options

1. Select item (1) "COIN OPTIONS" on the menu screen to set the game cost and related settings.
2. Press 'Select L/R' to select the required item.
3. Use the 'Decision' button to adjust the settings.
4. Select "EXIT" to return to the menu screen.

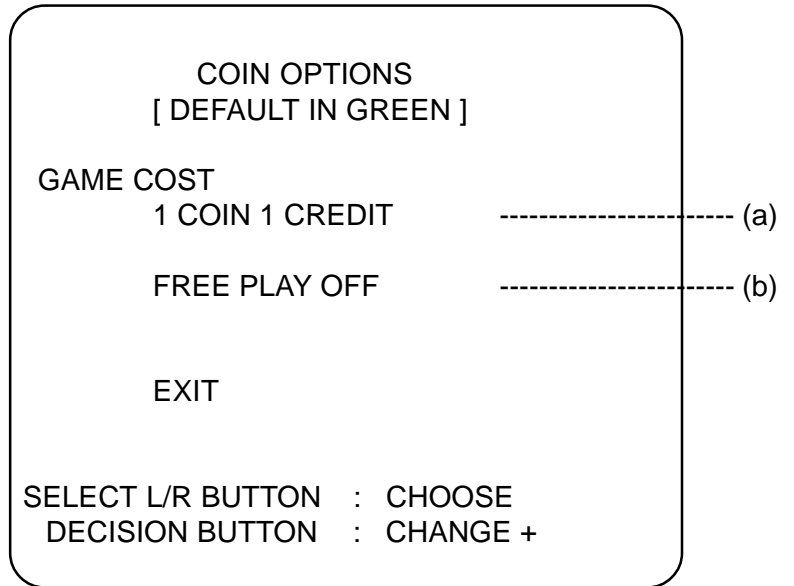

**Note :- The price of play on this machine is set within the Cashflow Coin Mech. Ensure that the Coin Options on the screen are set as shown in the following table.**

ITEM	CONTENTS	FACTORY SET
(a) Game Cost	No of Coins required for No. of credits - - - - - settable 1 - 9	<b>1 Coin 1 Credit</b>
(b) Free Play	Yes/No	<b>NO</b>



### 6-3-2 Game Options

1. Select item (2) "GAME OPTIONS" on the menu screen to set the game options and related settings.
2. Press 'Select L/R' to select the required item.
3. Press the 'Decision' button to adjust the settings. Standard settings are displayed in green.
4. Select "EXIT" and press 'Decision' to return to the menu screen.

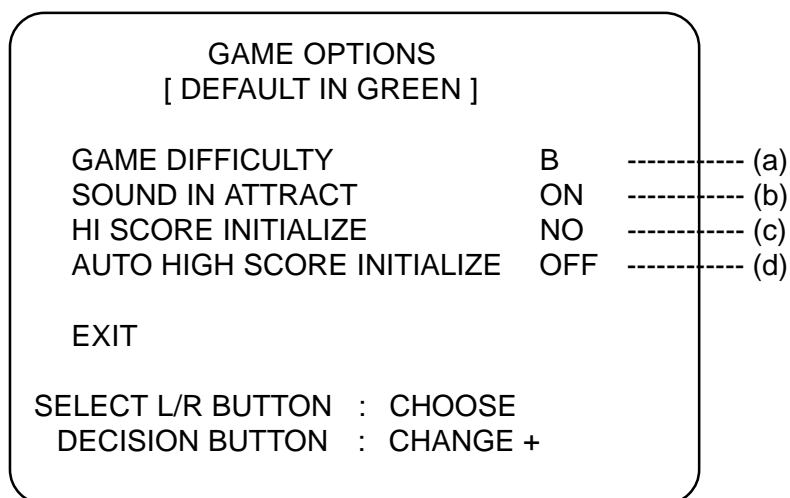

ITEM	DESCRIPTION	FACTORY SET
(a) Game Difficulty	A (easy) to C (hard)	B
(b) Sound in Attract	On / Off	On
(c) Hi Score Initialize	Yes / No (If Yes Hi Score will be reset when exiting test)	No
(d) Auto High Score Initialize	Yes / No (If Yes Hi Score will be reset every time the machine is switched OFF)	Off

### 6-3-3 I/O Test

1. Select item (3) "I/O Test" on the menu screen to test the switches, motor and step adjust.
2. Press 'Select L/R' to select the required item, then press the 'Decision' button to enter the test.
3. Select "EXIT" and press the 'Decision' button to return to the menu screen.

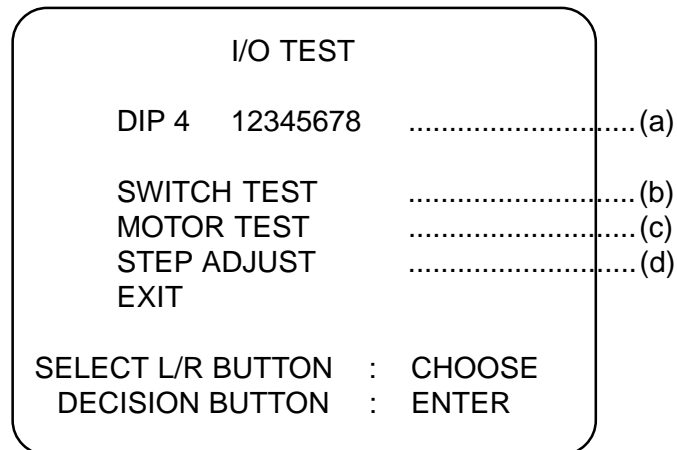

- (a) Shows condition of DIP SW 4 on the PCB. In normal operation all switches are OFF. (If a switch is ON, it will be displayed in red.)
- (b) For testing Switches and Control Pots. ([See 6-3-3-1](#) )
- (c) For testing the Step-Lock Motor. ([See 6-3-3-2](#))
- (d) For initializing the Step Control Pots. ([See 6-3-3-3](#))

**6-3-3-1 Switch Test**

1. Select Switch Test from the 'I/O Test' menu. The following screen will appear on the monitor.

*Note:- On entering Switch Test the Skis will be unlocked. Ensure that the Skis are returned to the locked condition at the end of the test by entering Motor Test (See 6-3-3-2)*

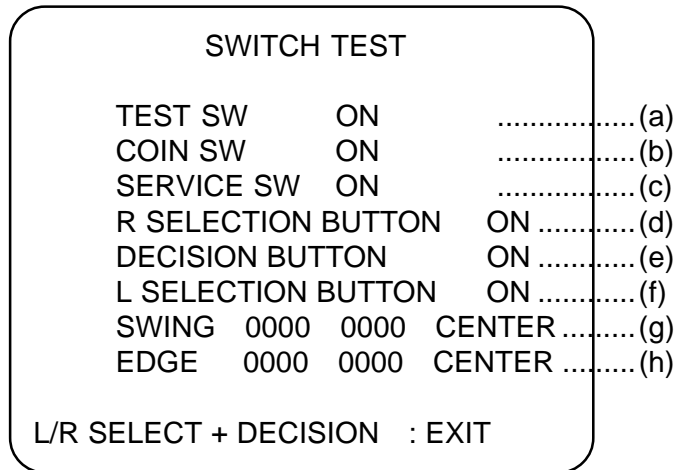

2. The word 'ON' will appear next to items (a) to (f) each time the respective switch is operated.  
 When the skis are pushed left, 'SWING-CENTRE' will change to 'LEFT' and 'OK' will appear just before it reaches the extreme left,. When the skis are pushed right, 'CENTRE' will change to 'RIGHT' and 'OK' will appear just before it reaches the extreme right. '0000' will increase when the skis are moved to the right and decrease when they are moved to the left.  
 When the skis are tilted, 'EDGE-CENTRE' will change to 'LEFT or RIGHT' and 'OK' will appear just before they are fully tilted. '0000' will change as the skis are tilted.

*Note: "EDGE" 'OK' will only appear if you stand and apply weight to the edges of the ski steps. There is no problem if 'OK' is not displayed when standing on the steps in the same way as normal play.*

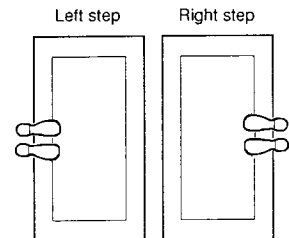

3. If 'OK' is not displayed when the edge is tilted left or right, re-initialize as described in [section 6-4](#) "Initialization After Replacing Parts".
4. Operate both of the 'Select L/R' buttons and 'Decision' button together to exit and return to the 'I/O Test' menu screen.

### 6-3-3-2 Motor Test

1. Select Motor Test from the 'I/O Test' menu. The following screen will appear on the monitor.

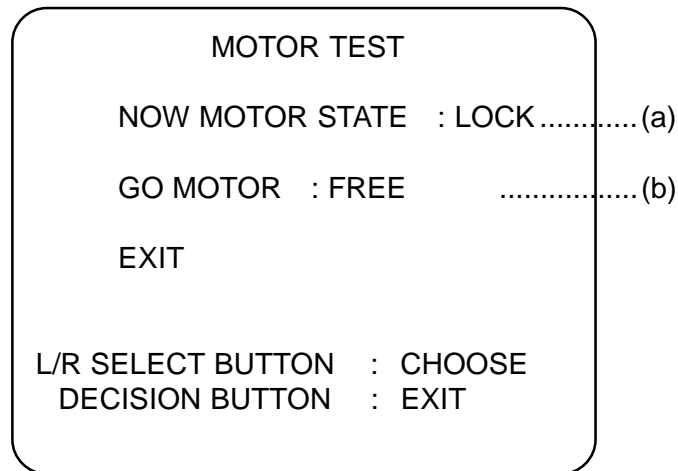

- (a) Displays the current condition of the Skis.  
Display will show 'LOCK - FREEING - FREE - LOCKING' as the Skis are tested.
- (b) Allows the Skis to be locked and unlocked.  
Display will show 'FREE - NOW MOVING - LOCK' as the Skis are being tested.

*Note:- Ensure Skis are in the locked condition before returning to normal game mode.*

### 6-3-3-3 Step Adjust

1. Select Step Adjust from the 'I/O Test' menu.

On entering 'STEP ADJUST' test, Step Adjust on the 'I/O' Menu Screen will blink and 'INITIALIZE COMPLETED' will appear and be blinking.

Ski Step initialization is now completed.

2. Select EXIT to return to the Main Menu Screen.

### 6-3-4 Sound Test

1. Select item (4) "Sound Test" on the menu screen to test the sound and speakers.
2. The following screen will appear on the monitor.

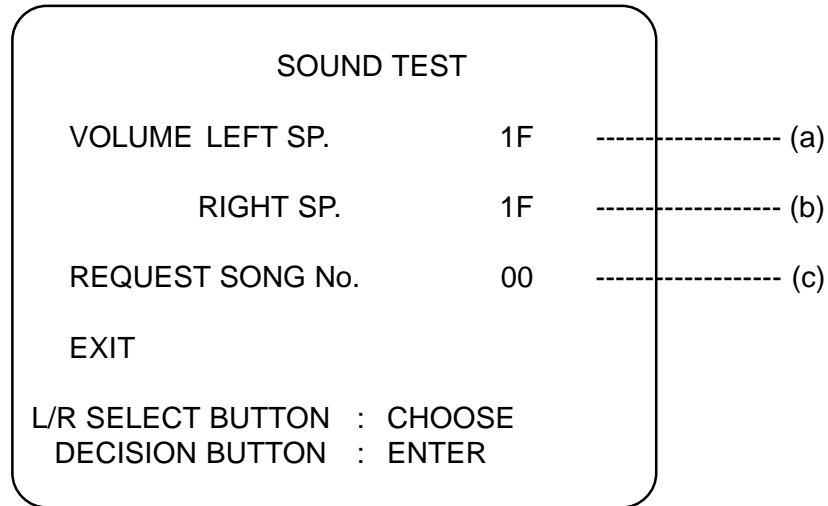

3. Select the required item by 'Select L/R' buttons. The selected item will 'blink'.
4. Pressing the Decision button will cause the selected value setting to blink.
5. Pressing 'Select R' will increase the value and 'Select L' will decrease the value.
6. Press 'Decision' button to return to item select mode.
7. When selecting the 'Request Song No.' test, 'Select R' button will increase the song number and 'Select L' will decrease the number. The 'Decision' button will produce the sound of the song number selected. (Request Song 01 will produce a stereo sound test. Sound will be produced from the speakers in the following order:- Left speaker, Right speaker, Both speakers)
8. Press both Select L/R buttons and Decision button together to return to Sound Test Menu from Request Song No. Test

Item	Description	Factory Set
a	Set left speaker volume      - - - - -      00 Quietest - 3F Loudest	3A
b	Set right speaker volume      - - - - -      00 Quietest - 3F Loudest	3A
c	Select sound for testing. Each number will produce a different sound. 01 will generate a stereo test.	- - -

### 6-3-5 Monitor Test

1. Select item (5) "Monitor Test" on the menu screen to set up and adjust the monitor.
2. On entering monitor test, the screen will display one of the following test patterns.

```

GRADATION PATTERN
CROSSHATCH          GREEN
CROSSHATCH          WHITE
WHITE WINDOW        (H)
WHITE WINDOW        (M)
WHITE WINDOW        (L)
INTERLACE PATTERN
VIEW ANGLE ADJUST (CRT)
VIEW ANGLE ADJUST (PROJECTOR)
FULL WHITE
    
```

3. Use 'Select L/R' buttons to change to the next pattern and 'Decision' button to return to the Main Menu.
4. Refer to monitor manual for monitor adjustments.

### 6-3-6 ADS Data

1. Select item (6) "ADS Data" on the menu screen to view machine history details.
2. The following screen will appear on the monitor.

ADS							
	RACE			T.T.			
	NOV	INT	EXP	NOV	INT	EXP	
PLAY	0000	0000	0000	0000	0000	0000	..... (a)
GOAL	0000	0000	0000	0000	0000	0000	..... (b)
EXT0	0000	0000	0000	----	----	----	..... (c)
EXT1	0000	0000	0000	----	----	----	..... (d)
EXT2	0000	0000	0000	----	----	----	..... (e)
GATE	----	----	----	0000	0000	0000	..... (f)
		NOV	INT	EXP			
RACE		000'00"00	000'00"00	000'00"00			..... (g)
T.T.		000'00"00	000'00"00	000'00"00			..... (h)
PLAY TIME		000' 00" 00					..... (i)
PLAY NUMBER		0000					..... (j)
			INITIALIZE				..... (k)
			EXIT				
L/R SELECT	:	CHOOSE					
DECISION	:	ENTER					

Item	Description
(a) Play	Total number of games played at each difficulty level for each course.
(b) Goal	Total number of games completed at each difficulty level for each course.
(c) Ext0	Number of games finishing at 1st extended time gate at each difficulty level in race game.
(d) Ext1	Number of games finishing at 2nd extended time gate at each difficulty level in race game.
(e) Ext2	Number of games finishing at 3rd extended time gate at each difficulty level in race game.
(f) Gate	Total number of gates completed for each difficulty level in T.T. game.
(g) Race	Total time in Hrs, Mins, Secs each difficulty level has been played in race game.
(h) T.T.	Total time in Hrs, Mins, Secs each difficulty level has been played in T.T. game.
(i) Play Time	Total time in Hrs, Mins, Secs game has been played.
(j) Play Number	Total number of game plays.
(k) Initialize	Resets all ADS Data to zero.

### 6-3-7 Others

1. Select item (7) "Others" on the menu screen.
2. On entering 'Others' the following screen will appear on the monitor.

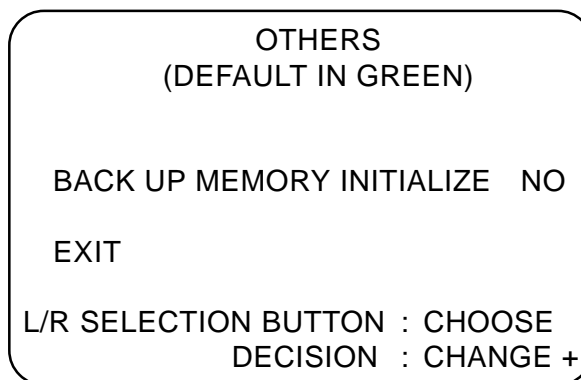

3. Selecting Back Up Memory Initialize will return all adjustable settings to factory preset.

## 6-4 Initialization After Replacing Parts

Initialization must be performed after replacing the game PC board, Rom or Step Controls. If initialization is not performed, the game will not function correctly. During initialization, ensure that the step edges are level.

### 6-4-1 Adjustment Method (a)

1. When the power is turned ON the step-lock motor is automatically checked. The motor check first locks the steps (If not already locked), unlocks, then locks them again.

*Note: Ensure that the test switch is OFF during motor check. Also ensure that the steps are not touched during the motor check, or the check will not be performed correctly.*

2. If the first lock is not completed within fifteen seconds from power up, an error display screen appears.

If this happens, refer to [section 6-4-2 "Adjustment Method \(b\)"](#), and initialize the controls. If the error display screen is still showing after the controls have been initialized, refer to section 6-4-3, "Handling Motor Errors".

After the motor check is successful the attract screen is displayed.

MOTOR ERROR 1  
PLEASE STEP ADJUST

3. To initialize the controls, Switch the test switch ON while pressing the service button. The screen displays the "SWITCH TEST" screen with INITIALIZE COMPETED flashing, Initialization is completed.
4. Turn the test switch OFF to return to normal game mode.

#### SWITCH TEST

TEST SW	ON
COIN SW	ON
SERVICE SW	ON
R SELECTION BUTTON	On
DECISION BUTTON	ON
L SELECTION BUTTON	ON
SWING	0000 0000 CENTER
EDGE	0000 0000 CENTER

INITIALIZE COMPLETED  
L/R SELECT + DECISION : EXIT



### 6-4-2 Adjustment Method (b)

1. Slide the test switch ON.
2. Turn the power OFF and then back ON again.
3. Select "I/O TEST" and press the decision button (View Change).
4. Select "STEP ADJUST" and press the decision button. The controls are now initialized.
5. After initialization is completed, turn the test switch OFF.  
The motor check begins. If the motor still does not operate correctly, there is a problem with the motor or switches, and an error will be displayed on the screen. Refer to section 6-4-3, below, "Handling Motor Errors", for fault finding.

### 6-4-3 Handling Motor Errors

If a problem has occurred with the step-lock motor, an error message and method of rectifying will be displayed on the screen.

1. Errors at Start-up
  - a. When the power is turned ON the step-lock motor is automatically checked. The motor check first locks the steps (If not already in locked position), unlocks, then locks them again.

*Note: Ensure that the test switch is OFF during motor check. Also ensure that the steps are not touched during the motor check, or the check will not be performed correctly.*

- b. If the first lock is not completed within fifteen seconds from power up, the following error display screen appears.  
If this happens, refer to [section 6-4-1](#) "Adjustment Method (a)", and initialize the controls.

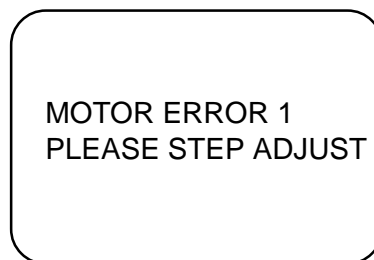

- c. If an error other than the one shown above is displayed, it is possible that a fuse has blown, there is a problem with the step-motor mechanism or the steps are not moving freely.

- d. If the first lock is completed within fifteen seconds, but the steps cannot be released, Motor Error 2 screen is displayed until the fault is rectified.

MOTOR ERROR 2  
OPERATION STOP!!

- e. If after the steps have been freed, they do not re-lock, as an emergency measure, Motor Error 3 screen is displayed. This allows the step-lock mechanism to be overridden and the game to be operated with the steps permanently in the free position.

MOTOR ERROR 3  
DO YOU WANT TO OPERATE  
  
YES>PUSH DECISION BUTTON  
NO>PUSH L/R SELECT BUTTON

***WARNING: It can be dangerous to operate the machine with the steps permanently free, so the fault MUST be repaired as soon as possible.***

If the game is to be operated with the steps in the free condition, press the decision button. If either the Left or Right Select button is pressed the game will cease to function until the fault has been rectified.

- 2. An Error Occurs During Play.
  - a. If the motor stops function during game play, the following error screen will be displayed.
  - b. Turn the power OFF and then back ON. The motor will be checked automatically.
  - c. If there is still a problem, follow the instructions detailed in [section 6-4-3 \(1\)](#), "Errors At Start-up".

WARNING!  
STEP LOCK DEVICE IS OUT  
OF ORDER  
CALL THE ATTENDANT  
IMMEDIATELY.

## 7. MAINTENANCE

**DANGER:** In order to prevent injury or electric shock to service personnel, ensure that the MAIN POWER IS OFF before attempting any maintenance.

**DANGER:** Before performing any work not described in this manual, be sure to contact your distributor to receive instructions or answers to questions.

### 7-1 Care of the Projector Monitor

The projection tube lenses have been manufactured from plastic material. Prevent contact with the lenses, because various lens faces have been provided with a special coating which is easily damaged.

**Only** the side of the lens directed towards the mirror, the mirror and the projection screen are allowed to be cleaned.

If cleaning is absolutely necessary, observe the following points :

- Blow off dust, or remove with a dust brush or soft lint-free cloth.
- If necessary, clean with a soft lint-free cloth, moistened with water to which a little detergent has been added.
- **DO NOT USE** organic solvents such as alcohol, dry cleaning naphtha, trichlorethylene, acetone, etc., these agents may cause permanent damage to the plastic lenses or projection screen.

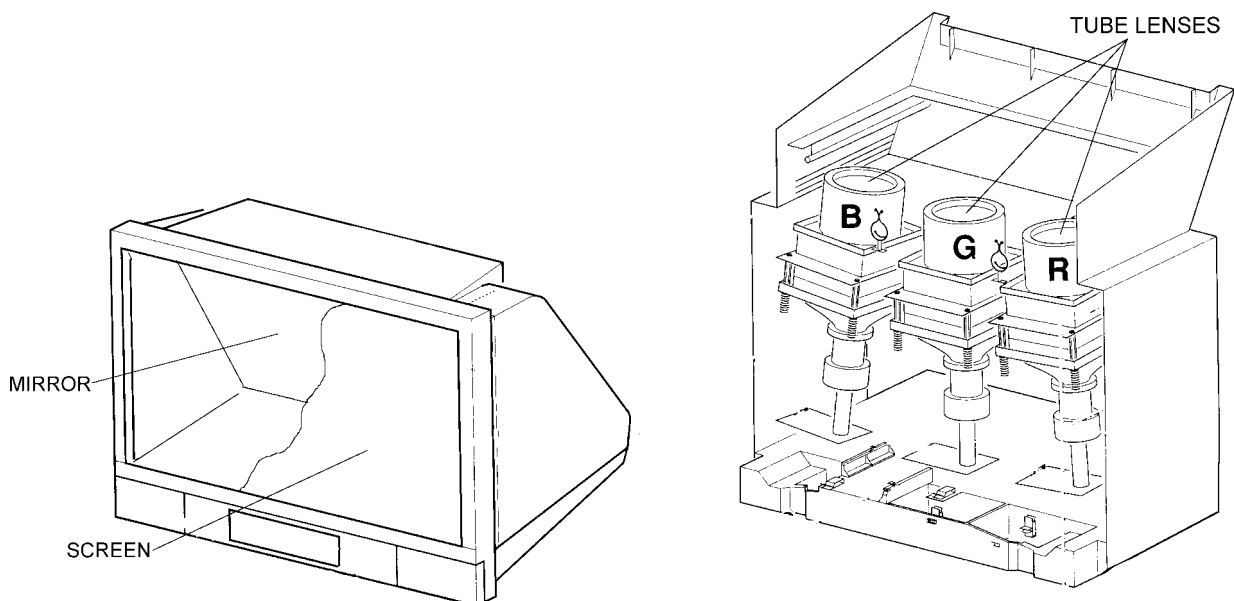

## 7-2 Replacing the Fluorescent Tube

- 1) Remove the ten socket button head screws (M5x12), and remove the side vac-forms (five screws on each vac-form)
- 2) Remove the two countersunk screws (M5x12) from the bottom of the acrylic.
- 3) Remove the two socket button head screws (M4x25), and remove the header acrylic retaining bracket.
- 4) Remove the header acrylic.
- 5) Replace the fluorescent tube.
- 6) Reassemble in reverse order.

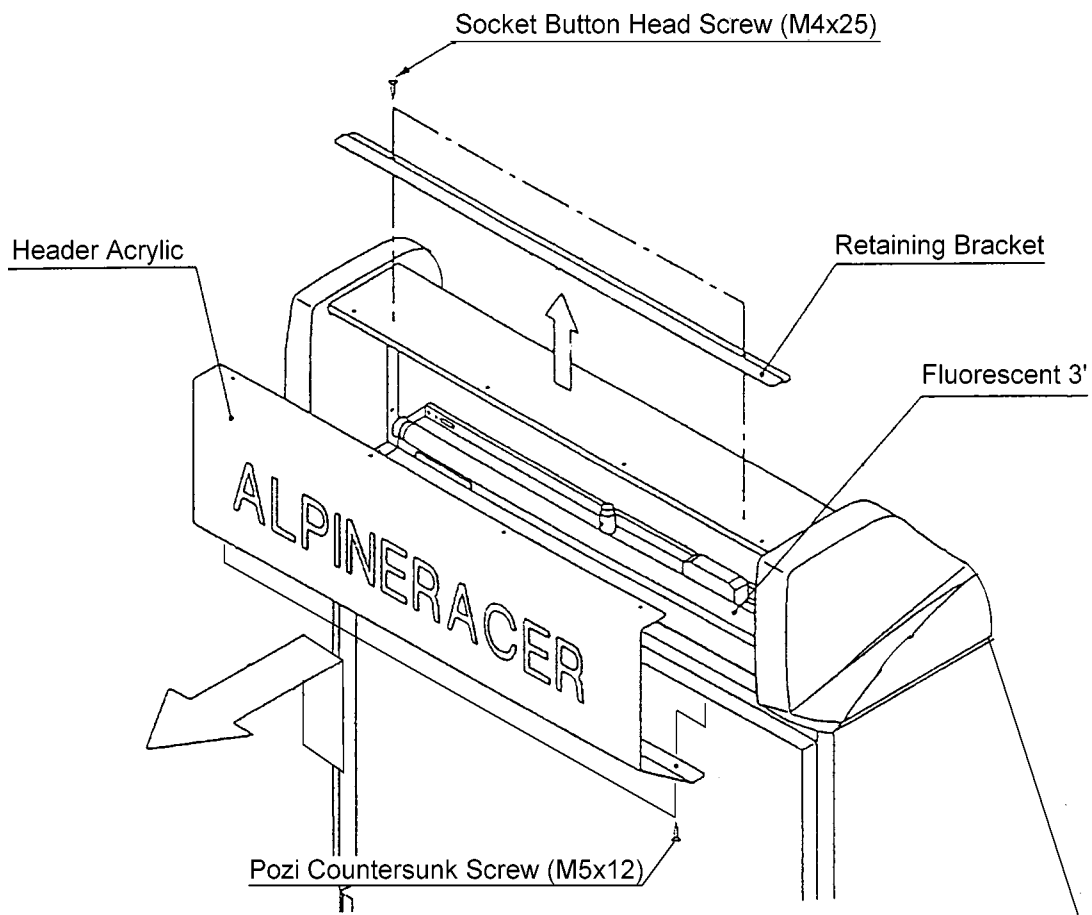

### 7-3 Replacing Push Button Switches and Lamps

- 1) Remove six security screws (M5x20) and two security screws (M5x12), and lift off the top cover taking care not to strain the wiring.
- 2) Disconnect the connector.

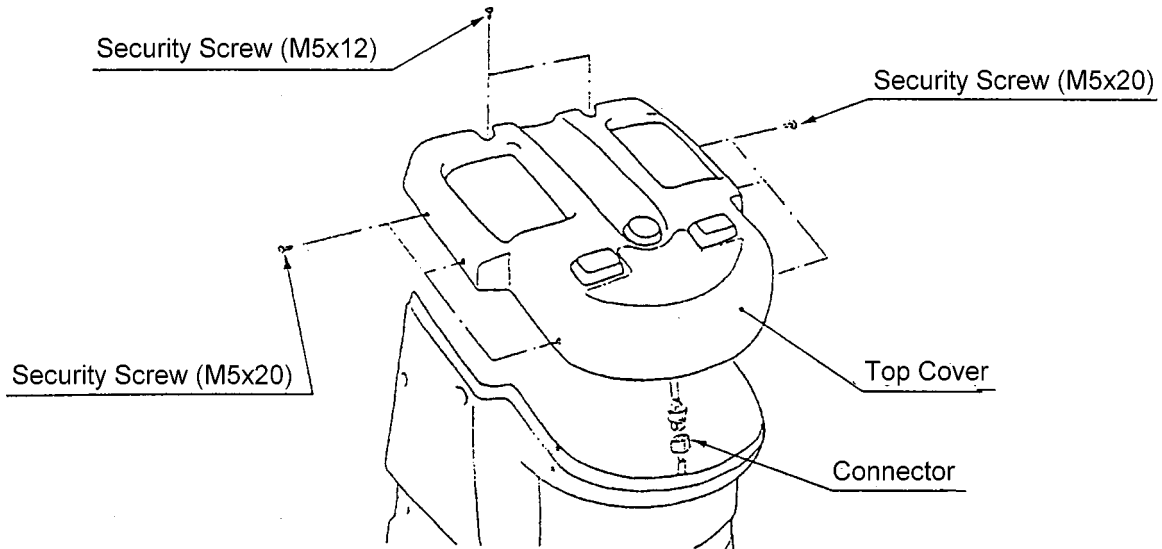

- 3) Separate the switch/lamp holder from the button by pulling it directly away from the button.

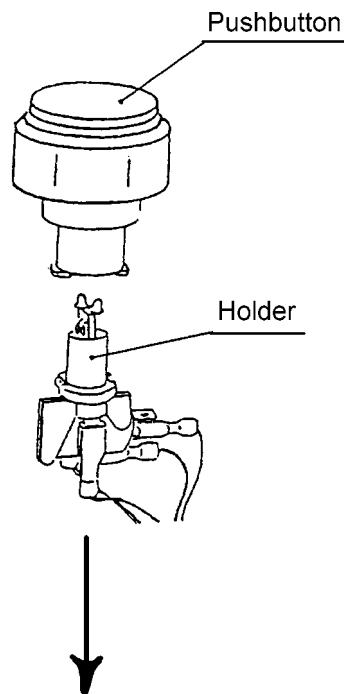

- 4) Replace the lamp or switch ensuring that the correct wires are replaced on the terminals.
- 5) Reassemble in reverse order.

## 7-4 Replacing the Step Limit Switches

**WARNING:** Ensure that the machine is disconnected from the main power supply before commencing work.

- 1) Remove the top cover. (See Section 7-3)
- 2) Remove four security screws (M5x12) securing each side vac-form to the mast assembly and remove both side vac-forms and front vac-form as one assembly.

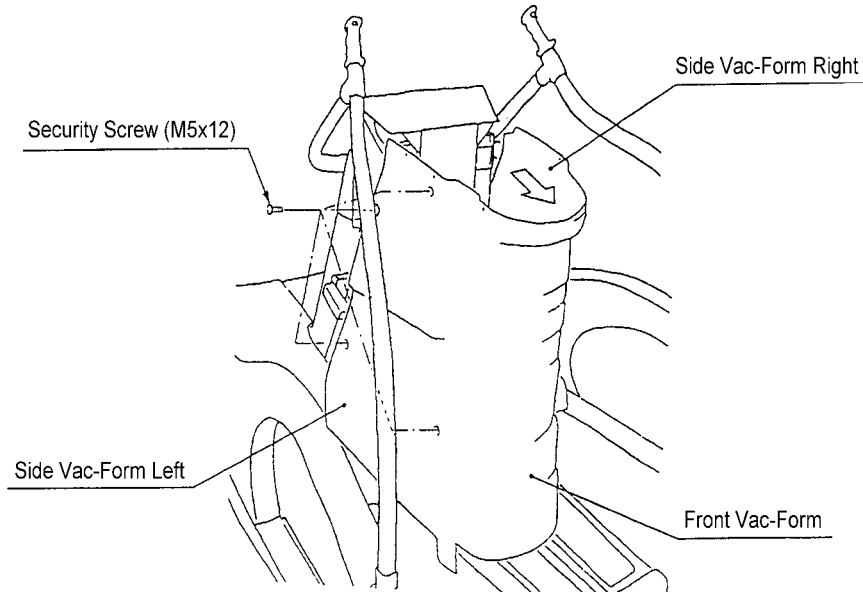

- 3) Remove two pozi head screws (M4x10) and remove the limit switch mounting bracket.

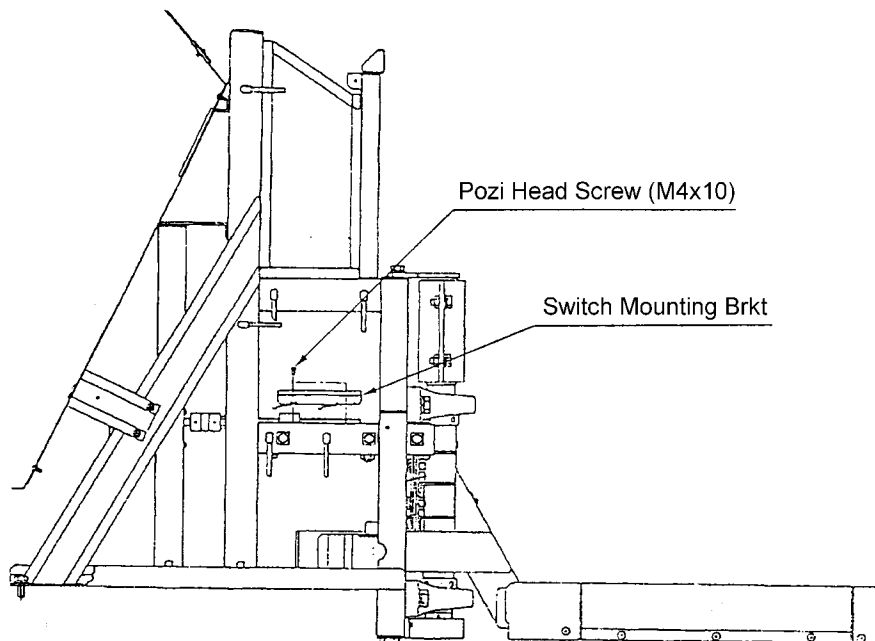

- 4) Remove two pozi head screws (M3x16) and replace the limit switch ensuring the wires are replaced on the correct terminals.

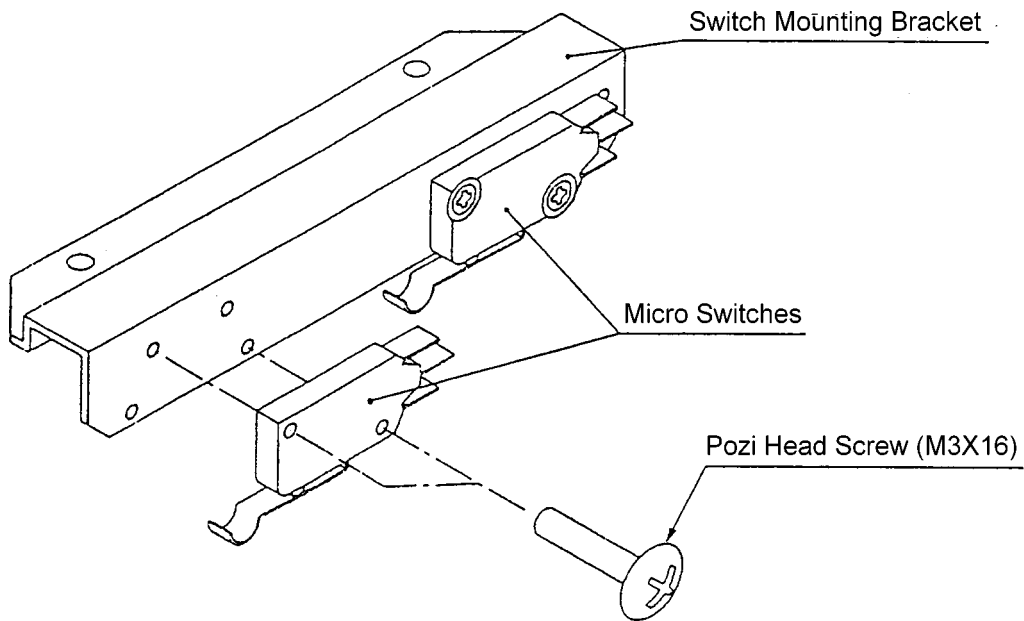

- 5) Reassemble in reverse order.

### 7-5 Replacing the L/R Turn Control Pot

**WARNING:** Ensure that the machine is disconnected from the main power supply before commencing work.

- 1) Remove eight security screws (M5x20) and remove the front Vac-form.
- 2) Remove two pozi head screws (M4x10) and remove the control pot cover.

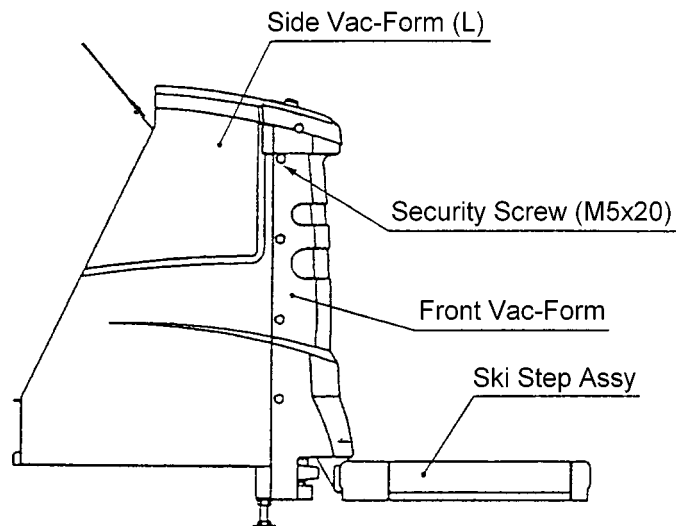

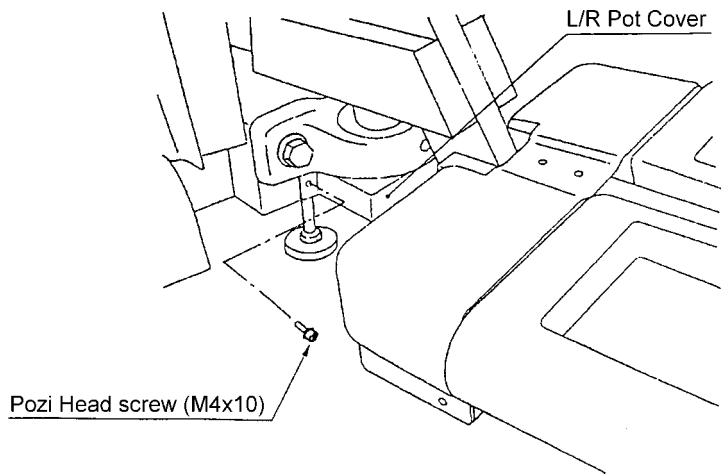

- 3) Disconnect the connector, slacken the pot retaining grub screw (M4x8) and remove the control pot and bracket.
- 4) Replace the control pot taking care to ensure that the wires are replaced to the correct terminals.

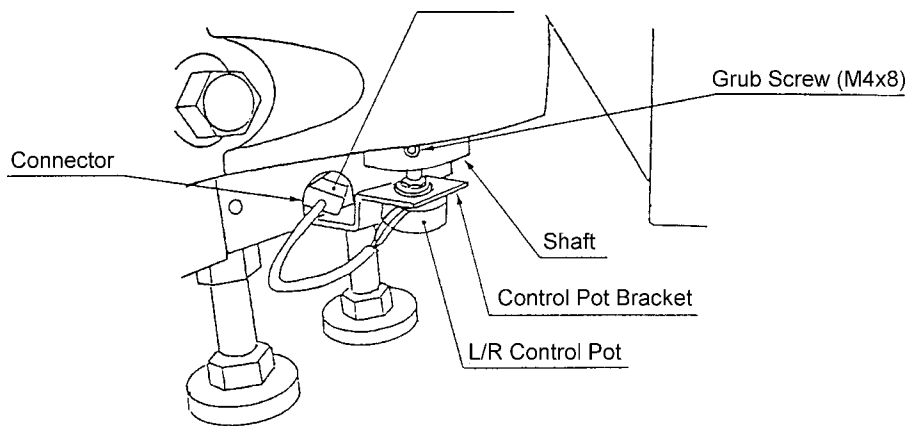

- 5) Reassemble in reverse order.
- 6) Re-initialize game. ([See 7-7 "Adjustments When Replacing Parts"](#))

**NOTE: When refitting the control pot ensure that the pot locating tab engages in the hole in the mounting bracket and that the grub screw (M4x8) engages on the flat of the pot shaft.**

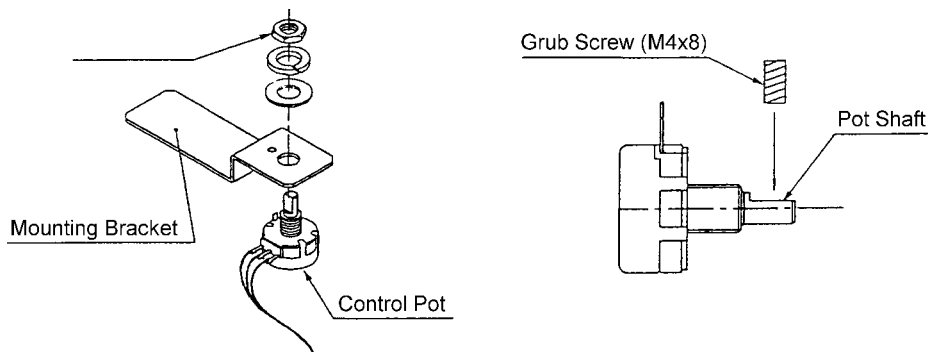



## 7-6 Replacing the Tilt Control Pot

- 1) Remove the front vac-form. (See Section 7-3)
- 2) Remove four security head screws (M5x12) and remove the Ski Step front vac-form.

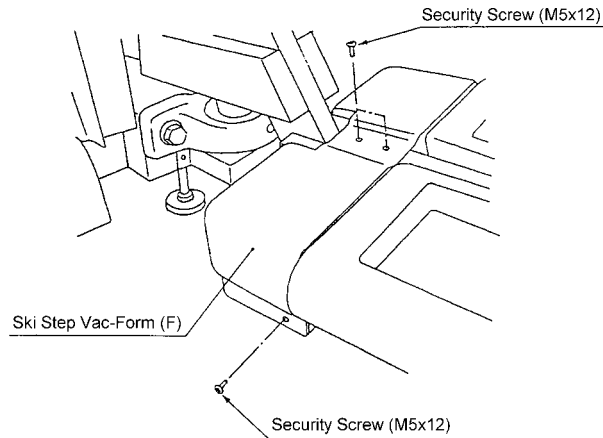

- 3) Disconnect the connector, slacken the pot retaining grub screw (M4x8) and remove the control pot and bracket.

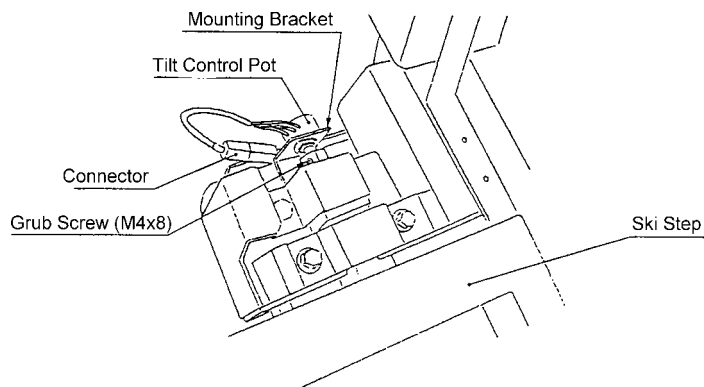

- 4) Replace the control pot taking care to ensure that the wires are replaced to the correct terminals.
- 5) Reassemble in reverse order.
- 6) Re-initialize game. (See 7-7 "Adjustments When Replacing Parts")

**NOTE:** When refitting the control pot ensure that the pot locating tab engages in the hole in the mounting bracket and that the grub screw (M4x8) engages on the flat of the pot shaft.

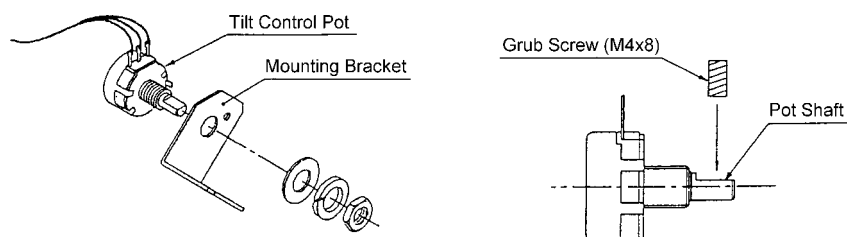

## 7-7 Removing the Step Rubber

- 1) Remove three security screws (M5x12) and retaining bracket from the outside edge of the step rubber, Lift the rubber edge and remove the three inner security screws (M5x12) and retaining bracket.

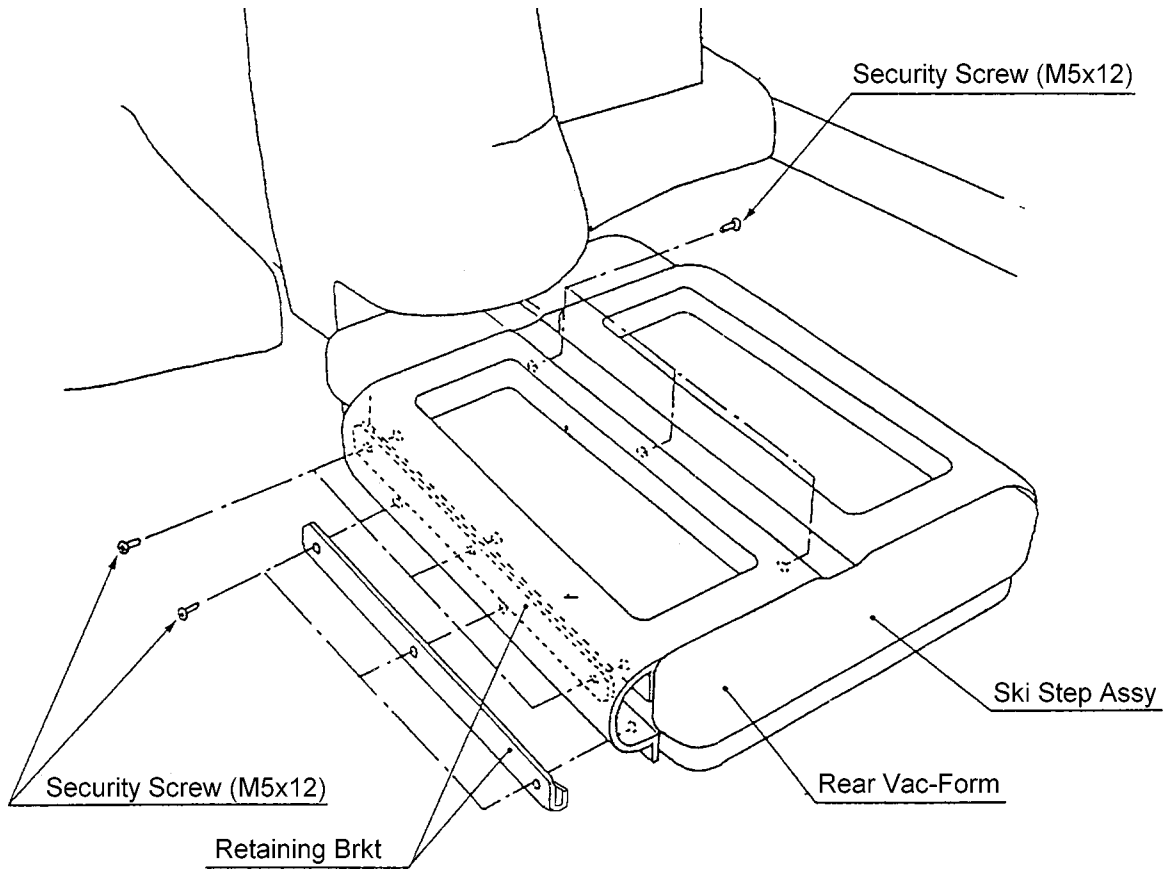

- 2) Tilt the step assembly and remove three security screws (M5x12).

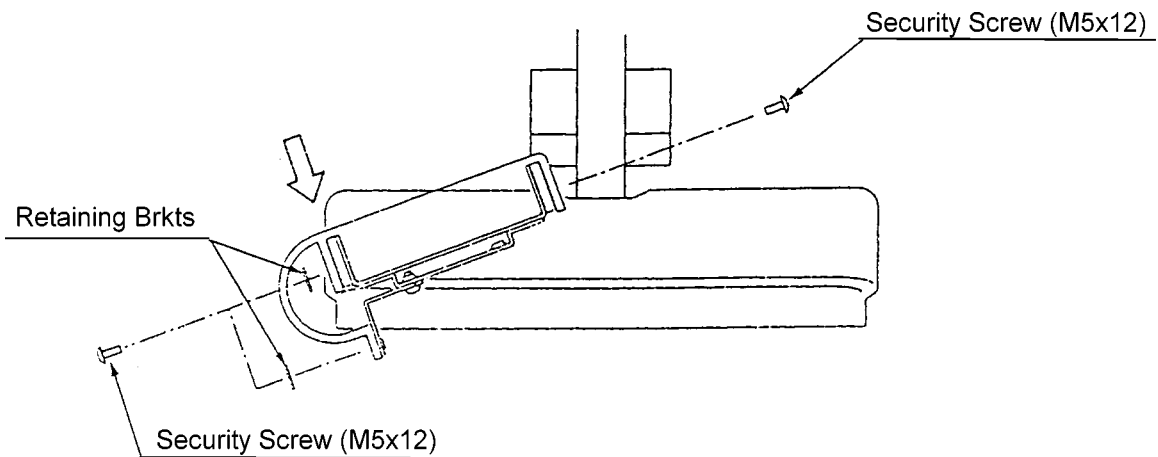

- 3) Remove the step rubber.
- 4) Refit in reverse order.

## 7-8 Step-Lock Maintenance

### 7-8-1 Releasing the Step-Lock

1. Turn the power switch ON
2. Press the service switch, and start the game.
3. When the game starts, the restriction plate (see diag.) moves to the released position.
4. When the steps are released, turn the power OFF.
5. To re-lock the steps turn the power ON and the steps will re-lock in the power up motor check.

### 7-8-2 Greasing the Step-Lock

#### WARNING

Make sure that the power is turned OFF.  
If work is to be carried out with the covers removed, take care not to trap hands or fingers in the mechanism.

The step-lock should be greased every three to four months.

1. Remove the control panel and vac-forms (See sections 7-3 and 7-4).
2. Apply grease to the following locations.
  - Between the restriction plate and guide rails, and between the cam follower.
  - Screw shaft
  - Pillow shaft
  - Sub torsion bar axle

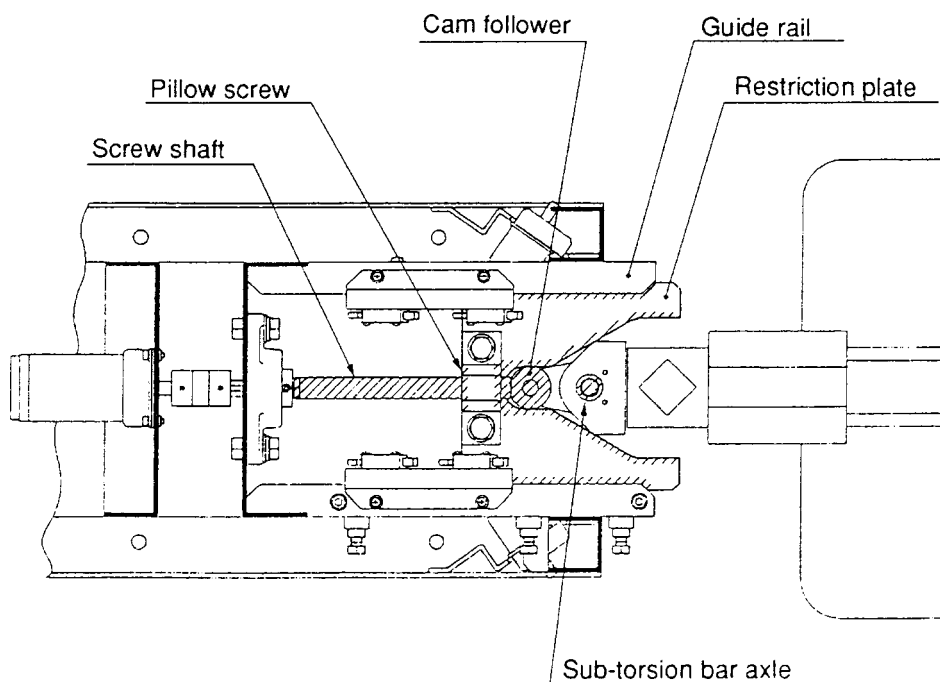

### 7-8-3 Inspecting the Pillow Unit

#### WARNING

Make sure that the power is turned OFF.  
If work is to be carried out with the covers removed, take care not to trap hands or fingers in the mechanism.

When greasing the step-lock, inspect the pillow assembly for any problems.

1. Release the step-lock and swing the steps to the left and right, and check the pillow units for any wear. Also check that the Hex Head Screws (M14x45) are tight.
2. Swing the steps left and right, and check that the main torsion bar is secure. Also check that the Hex Head Screws (M10x25) are tight.
3. Reassemble the vac-forms and control panel. Remember to connect the connector when refitting the control panel.

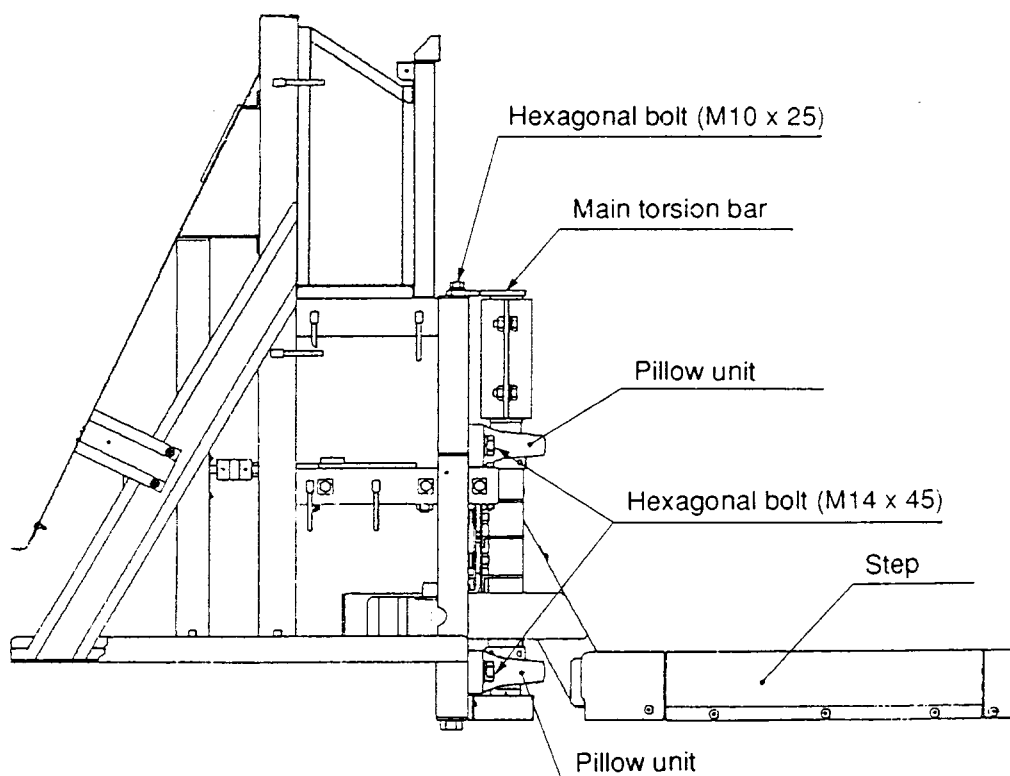

## 8. TROUBLE SHOOTING

- Ensure that the power is turned OFF before making adjustments or replacing parts.
- If none of the items below correspond to your problem, or if the problem is not corrected by the treatment described below, contact your dealer for further advice.
- Always return PC Boards to your dealer for repair. Never test the PC board for continuity with a multimeter or similar device. The PC Board contains sensitive devices which could be damaged or even destroyed by the internal voltage of such test equipment.
- When sending parts for repair, clearly indicate the problem, and send them in secure and adequate packing. Especially in the case of sending PC Boards, wrap them in sponge or bubble wrap prior to packing, so that they do not receive excessive shock.

### 8-1 General Problems

Symptom	Cause	Treatment	Ref. Page
The machine does not work even though the power is ON.		Switch OFF and back ON.	
Operation is unstable or the machine does not operate correctly.	Is the mains supply within 10% of the rated voltage.	Remove any heavy duty equipment (air conditioners, large rides, etc.) from the same power line, and ensure that the supply is within the correct limits.	pg21 6-4
	Have parts been changed.	Reinitialize the game.	
The game goes off.	Is the mains-in plug secure.		
	Has a fuse blown.	Switch the power OFF and check the mains-in filter fuse and fuses on the PSU board.	

### 8-2 Projector Assy

Symptom	Cause	Treatment	Ref. Page
There is no picture on the monitor.	Monitor switched OFF.	Check ON/OFF switch on front of monitor.	
	Is the signal loom connected properly.	Check SCART connector is secure and connected to the AV1 connector.	

### 8-3 Header Assembly

Symptom	Cause	Treatment	Ref. Page
The fluorescent lamp does not come on.	Is the connector loose or disconnected.	Connect the connector securely.	pg44 schematic
	Is the fluorescent tube or starter burned out.	Replace tube or starter.	pg25 7-2

### 8-4 Mast Assembly

Symptom	Cause	Treatment	Ref. Page
There is no sound from a speaker.	Is a connector loose or disconnected.	Connect the connector.	pg44 schematic
	Is the volume too low.	Adjust volume setting.	pg18 6-3-4
"WARNING!" is displayed. the step lock does not work.	Is a connector loose or disconnected.	Connect the connector.	pg44 schematic
	Is a fuse blown.	Check and replace fuse on PSU board.	
Pushbutton lamp does not light.	Is a connector loose or disconnected.	Connect the connector.	pg44 schematic
	Is the lamp loose in the holder.	Insert lamp properly.	pg26 7-3
	Is the lamp burned out.	Replace lamp.	pg26 7-3

### 8-5 Step Assembly

Symptom	Cause	Treatment	Ref. Page
The step control does not work.	Is a connector loose or disconnected.	Connect the connector.	pg44 schematic
	Has the game been initialized.	Initialize the game.	pg21 6-4
	Is the control pot broken.	Perform the switch test to check control.	pg16 6-3-3-1
		Replace the control pot.	pg28 7-5
The tilt control does not work.	Is a connector loose or disconnected.	Connect the connector.	pg44 schematic
	Has the game been initialized.	Initialize the game.	pg21 6-4
	Is the control pot broken.	Perform the switch test to check control.	pg16 6-3-3-1
		Replace the control pot.	pg30 7-6

## 9. PARTS

**WARNING:** Many of the parts used in this machine, including metal work, have been manufactured to special specifications. To ensure continuing safety and correct operation, replace only with genuine NAMCO parts.

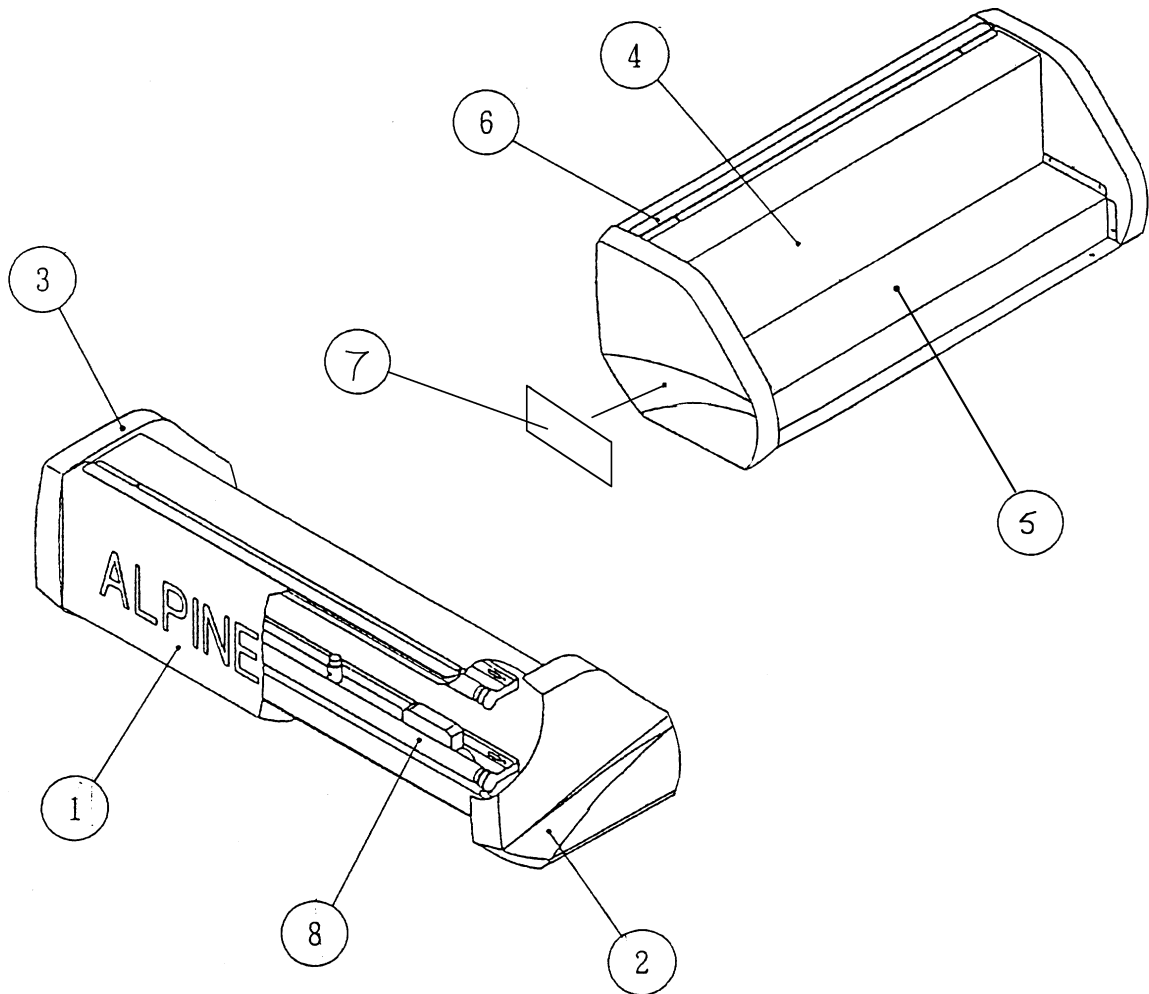

ITEM	DESCRIPTION	PART No.
1	HEADER ACRYLIC	30000222
2	HEADER VAC-FORM - RHS	45000721
3	HEADER VAC-FORM - LHS	45000720
4	HEADER WOODEN HOUSING	37100086
5	HEADER METAL HOUSING COVER	45000584
6	HEADER ACRYLIC RETAINING BRACKET	45000581
7	HEADER VAC-FORM DECAL LHS/RHS	40000266
8	FLUORESCENT TUBE 3ftx1" 20w T8	64500013

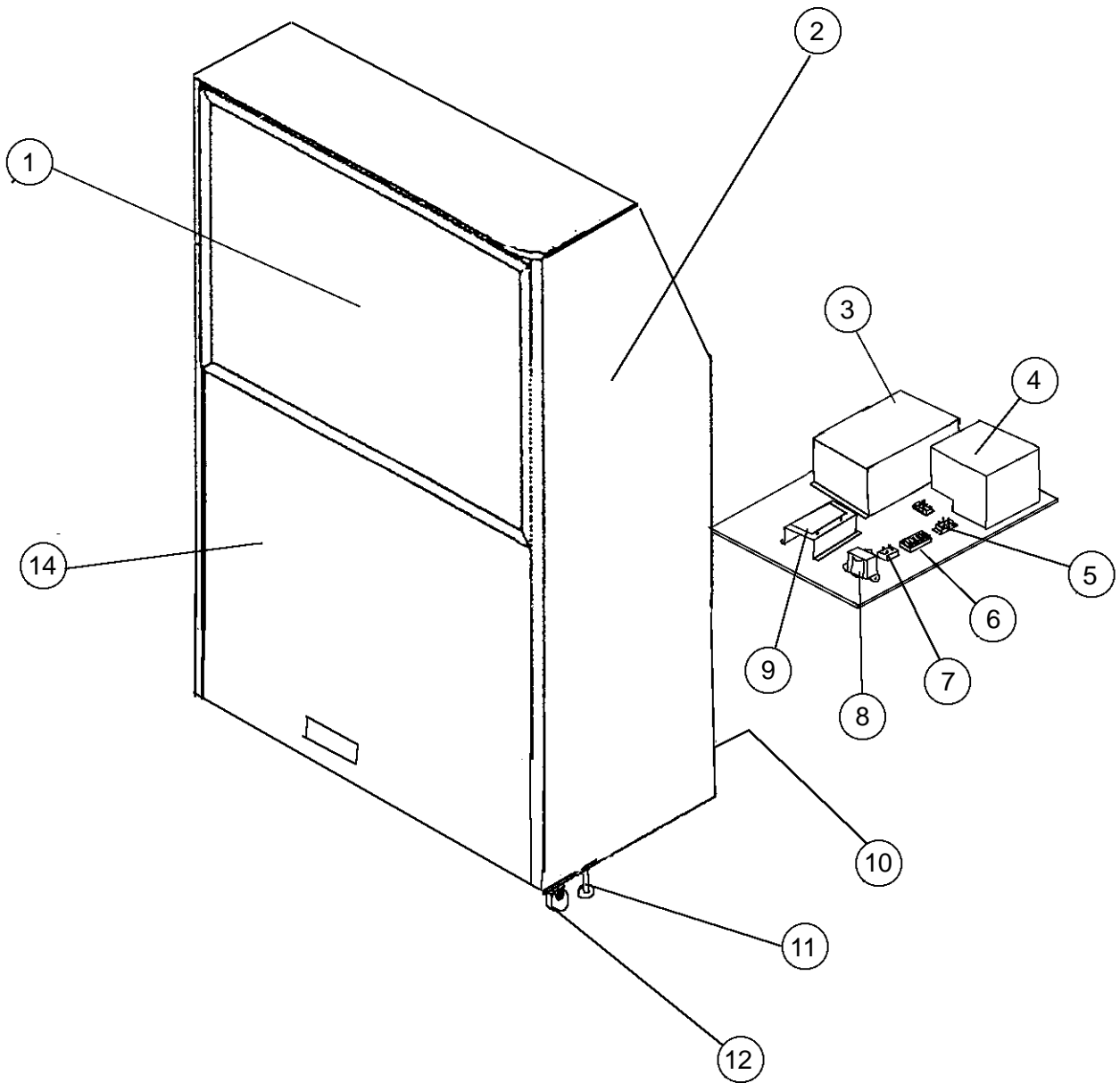

ITEM	DESCRIPTION	PART No
1	THOMSON 52" PROJECTION MONITOR	84000030
2	PROJECTOR CABINET SIDE DECAL - LHS/RHS	40000284
3	ALPINE RACER PCB ASSY - SYSTEM 22	XAR-PCB
4	SMPSU 5v/30A - 12v/5A	83000001
5	ELKAY BLOCK 5 WAY	66000014
6	FUSE 1¼" 2A QUICK-BLO	63500504
	FUSE 1¼" 3A SLO-BLO	63500547
7	BRIDGE RECTIFIER 25amp	71000040
8	TRANSFORMER	67700019
9	3 CHANNEL POWER AMPLIFIER	45000725
10	SCHAFFNER MAINS-IN FILTER	66000016
11	ADJUSTABLE FOOT M16x95	88300079
12	SWIVEL CASTOR 75mm	59000005
14	PROJECTOR CABINET FRONT DECAL	40000283



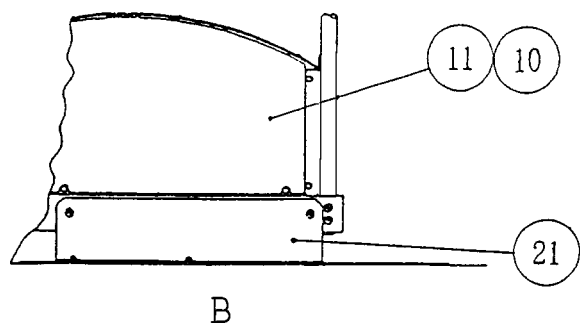
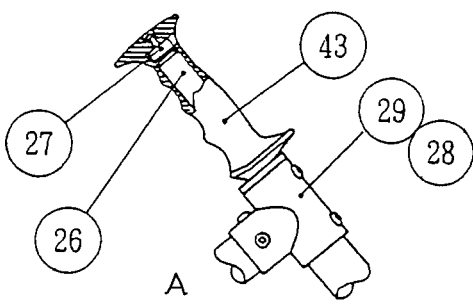
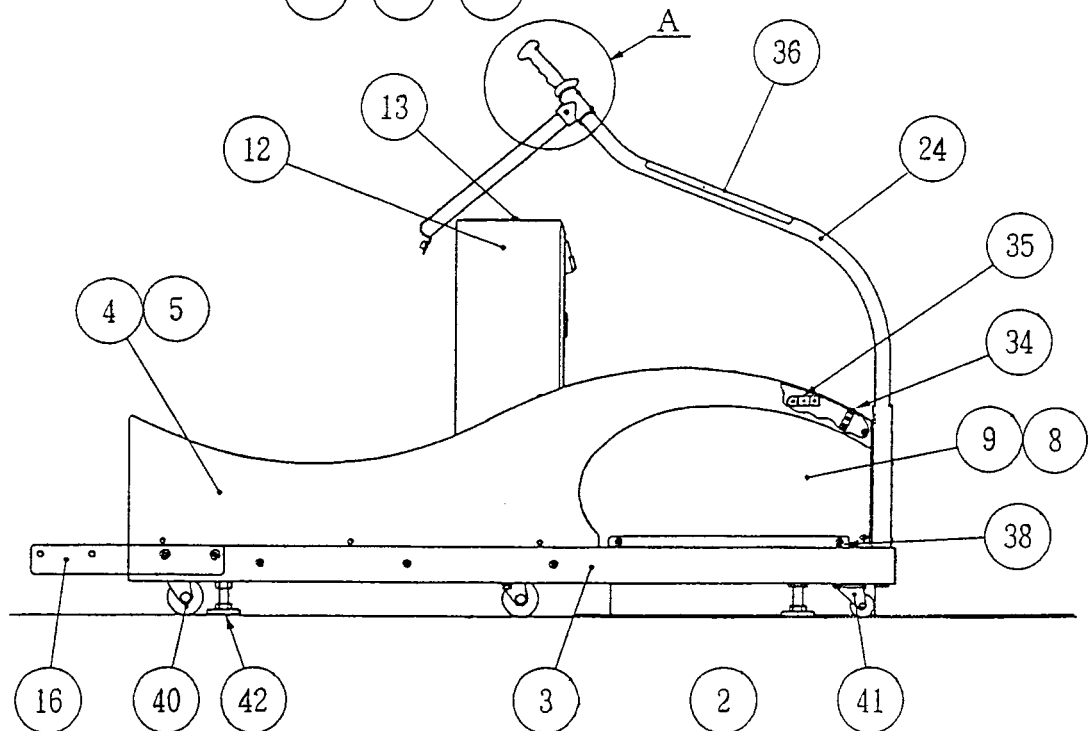
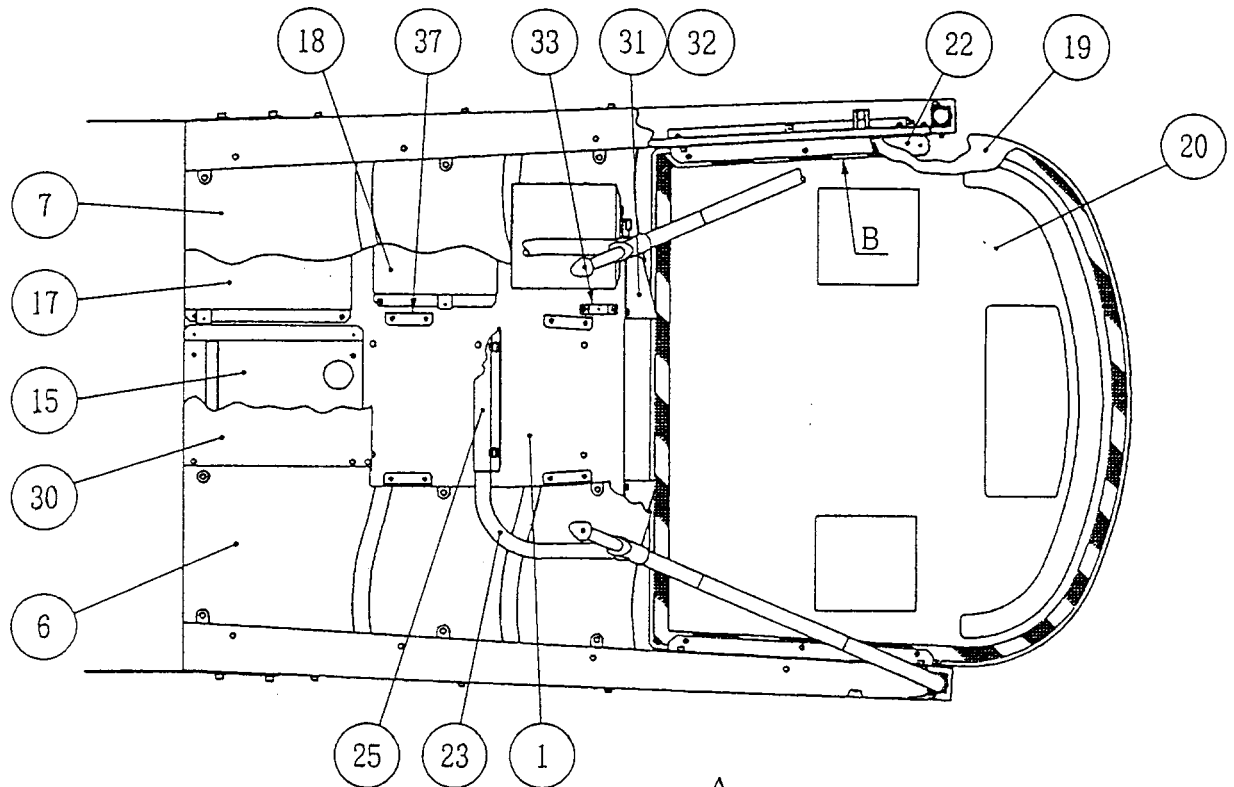

ITEM	DESCRIPTION	PART No
1	MAIN BASE METALWORK	45000585
2	MAIN BASE EXTENSION ARM - RHS	45000586
3	MAIN BASE EXTENSION ARM - LHS	45000587
4	MAIN BASE EXTENSION ARM VAC-FORM - LHS	45000588
5	MAIN BASE EXTENSION ARM VAC-FORM - RHS	45000589
6	SNOW FIELD VAC-FORM - LHS	45000590
7	SNOW FIELD VAC-FORM - RHS	45000591
8	SIDE WOOD - LHS	37100078
9	SIDE WOOD - RHS	37100079
10	SIDE WOOD DECAL - LHS	40000267
11	SIDE WOOD DECAL - RHS	40000268
12	COIN TOWER	45000592
13	PLAY INSTRUCTION DECAL	40000276
15	FRONT CENTRE EXTENSION BOX	45000595
16	PROJECTOR/BASE JOINT BRACKET - LHS	45000722
	PROJECTOR/BASE JOINT BRACKET - RHS	45000723
17	FRONT EXTENSION BOX - LHS/RHS	45000597
18	REAR EXTENSION BOX - LHS/RHS	45000598
19	STEP ON FLOOR BASE	45000599
20	STEP ON FLOOR BASE SAFETY DECAL	40000269
21	FLOOR BASE SUPPORT BRACKET - LHS/RHS	45000600
22	FLOOR BASE SECURING PLATE	45000601
23	SKI POLES FRONT SUPPORT BAR	45000602
24	SKI POLE - LHS	45000710
	SKI POLE - RHS	45000711
25	SKI POLES FRONT SUPPORT BAR CLAMP	45000604
26	SKI POLE GRIP BAR - LHS/RHS	45000605
27	SKI POLE GRIP WASHER	45000606
28	SKI POLE/GRIP BAR JOINT - RHS	45000607
29	SKI POLE/GRIP BAR JOINT - LHS	45000608
30	FRONT CENTRE TOP COVER PLATE	45000609
31	SNOW FIELD VAC-FORM SUPPORT BRACKET REAR - RHS	45000611
32	SNOW FIELD VAC-FORM SUPPORT BRACKET REAR - LHS	45000610
33	SNOW FIELD VAC-FORM REAR SECURING BRACKET	45000612
34	BASE EXTENSION ARM VAC-FORM TOP FIXING BRACKET	45000613
35	BASE EXTENSION ARM VAC-FORM LHS/RHS FIXING BRACKET	45000614
36	SKI POLE DECAL	40000270
37	MAST SIDE VAC-FORM LOWER KICK BRACKET	45000615
40	SWIVEL CASTOR - 75mm	59000009
41	SWIVEL CASTOR - 50mm	59000001
42	ADJUSTABLE FOOT M20x70mm	25000010
43	SKI POLE GRIPS (pair) - BLACK	45000617

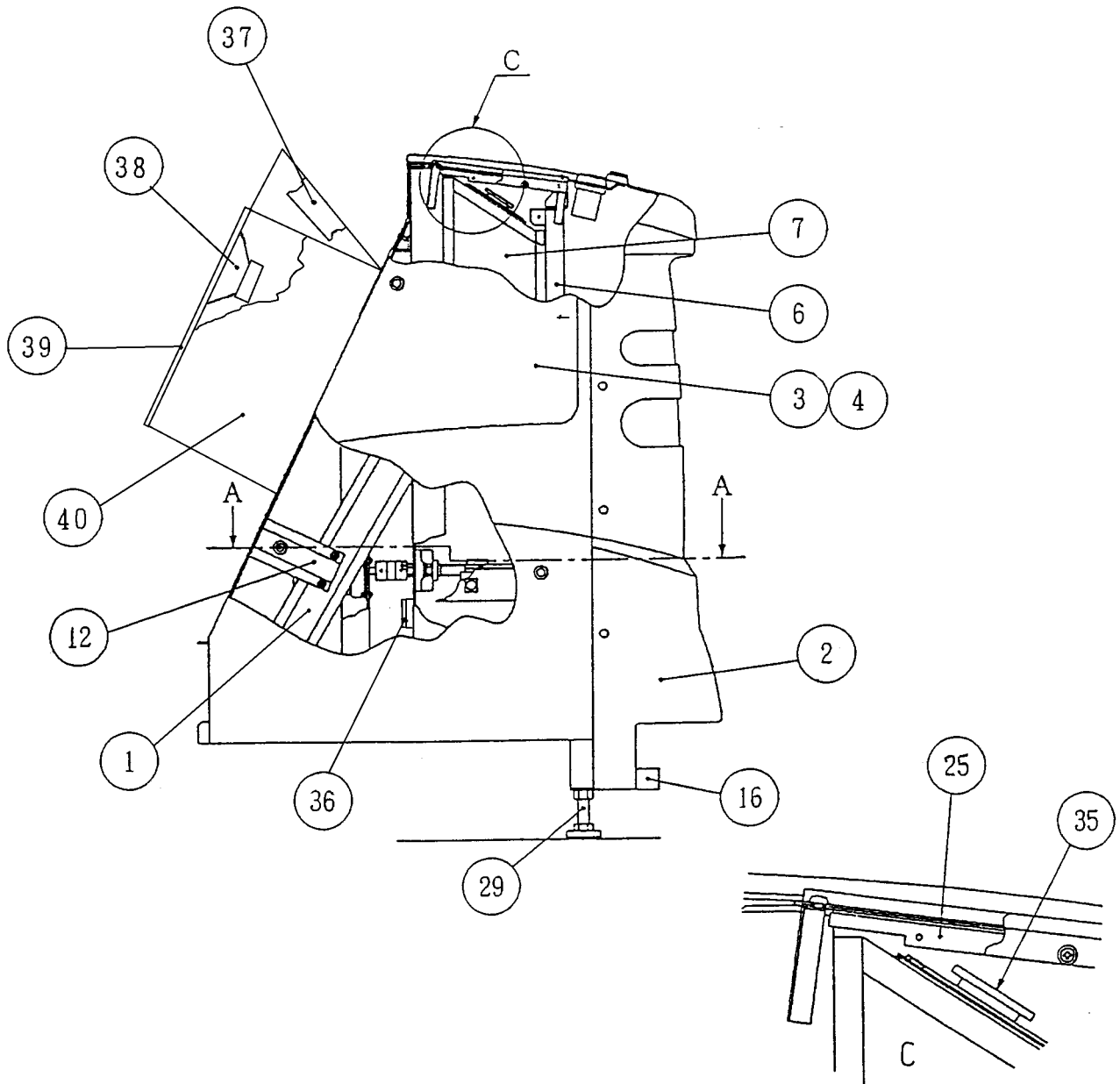
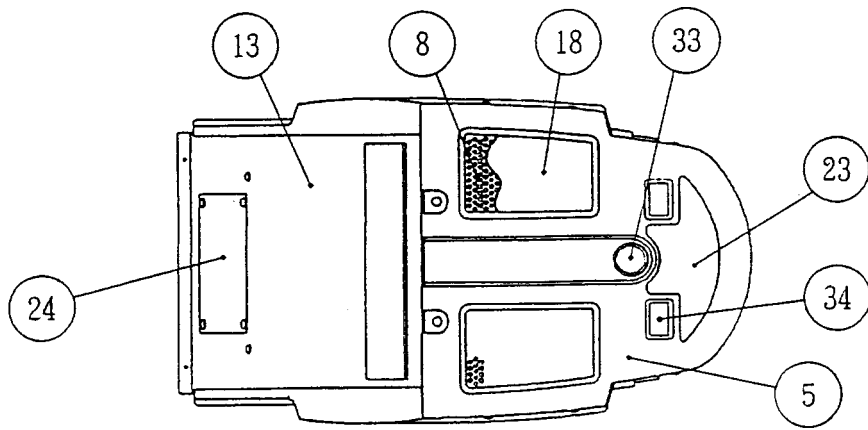

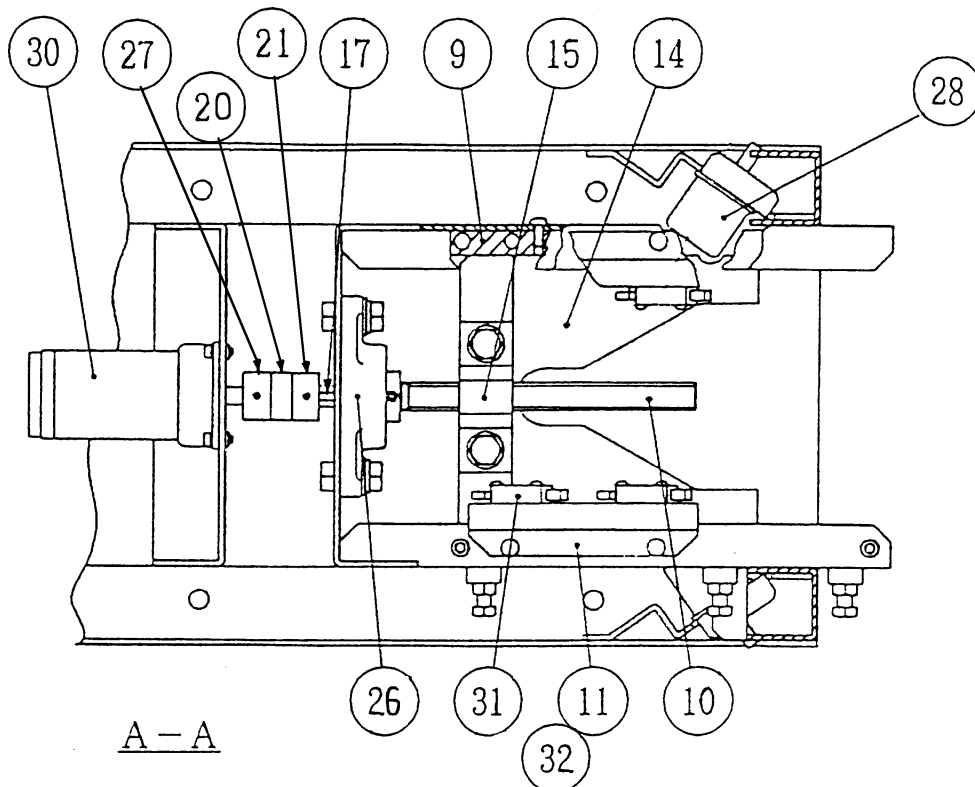

ITEM	DESCRIPTION	PART No.
1	MAIN MAST METAL WORK	45000643
2	MAST FRONT COVER VAC-FORM	45000644
3	MAST SIDE VAC-FORM - LHS	45000645
4	MAST SIDE VAC-FORM - RHS	45000646
5	CONTROL PANEL VAC-FORM	45000647
6	SPEAKER MESH FRONT SUPPORT BRACKET	45000648
7	LOUDSPEAKER WOODEN CABINET	37100081
8	LOUDSPEAKER GRILLE	45000649
9	LOCKING PLATE GUIDE RAIL	45000650
10	THREAD ROLLED DRIVE SHAFT CS-16V149	45000715
11	LIMIT MICRO SWITCH MOUNTING BRACKET	45000652
12	FRONT CLOSING BRKT SUPPORT BRACKET	45000653
13	FRONT CLOSING BRACKET	45000654
14	LOCKING PLATE	45000655
15	THREAD ROLLED DRIVE GUIDE	45000656
16	L/R POT COVER	45000658
17	WOODRUFF KEY 25x4x4	45000659
18	SPEAKER GRILLE SPONGE	45000660
19	PLAY INSTRUCTION MOUNTING BRACKET	45000661
20	JOINT L-050	45000668

ITEM	DESCRIPTION	PART No.
21	JOINT AL-050-12	45000667
22	PLAY INSTRUCTION ACRYLIC	30000220
23	CONTROL PANEL DECAL	40000271
24	FRONT CLOSING BRACKET COVER PLATE	45000662
25	SPONGE RETAINING BRACKET	45000663
26	BEARING UCFL201	45000669
27	JOINT AL-050-10	45000666
28	L/R STOP BUMPER K1-40	45000664
29	ADJUSTABLE FOOT M16x95	88300079
30	LOCKING MOTOR 24Vdc-350.8RPM-0.221A	45000714
31	LIMIT MICRO SWITCH V1541C25	60000012
32	FAN SWITCH MOUNTING BRACKET	45000697
33	PUSHBUTTON MCPB - RED	60200247
34	PUSHBUTTON RPB - YELLOW	60200227
35	LOUDSPEAKER 5½" FULL RANGE	62000065
36	MOTOR FILTER BOARD	45000743
37	AXIAL FAN 130mm	67000074
38	SUB BASS DRIVE SPEAKER - 6½"	62000068
39	SUB BASE SPEAKER GRILLE	45000701
40	SUB BASS WOOFER CABINET	37100084

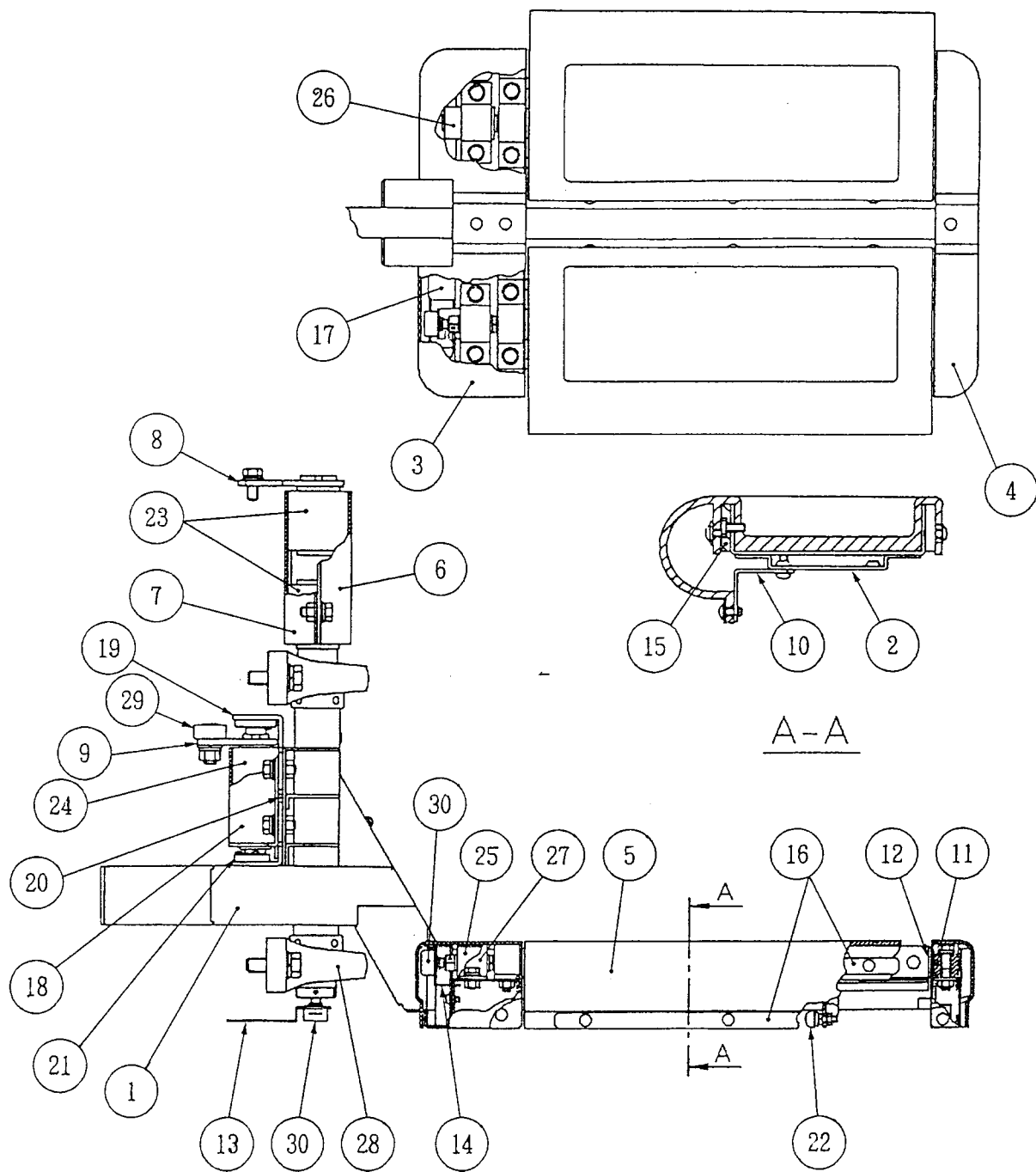

ITEM	DESCRIPTION	PART No
1	STEP ASSY MAIN METAL STRUCTURE	45000618
2	STEP TRAY ASSY	45000619
3	STEP VAC-FORM - FRONT	45000620
4	STEP VAC-FORM - REAR	45000621
5	STEP RUBBER	45000622
6	ROSTA SPRING BRACKET - FRONT 38x60	45000623
7	ROSTA SPRING BRACKET - REAR 38x60	45000624
8	ROSTA SPRING SWING BRACKET 38x60	45000625
9	STEP CENTERING ARM	45000626
10	STEP RUBBER RETAINING BRACKET	45000627
11	STEP SWING BEARING	45000628
12	STEP SWING BEARING SPACER	45000637
13	SWING L/R POT MOUNTING BRACKET	45000628
14	EDGES POT MOUNTING BRACKET	45000629
15	STEP LOCATING PLATE - UPPER	45000630
16	STEP RUBBER SUPPORT BRACKET	45000631
17	EDGES POT COVER BRACKET	45000632
18	ROSTA SPRING BRACKET	45000639
19	ROSTA SHAFT BEARING BRACKET - TOP	45000640
20	ROSTA SHAFT BEARING BRACKET - BOTTOM	45000641
21	BEARING LFB-1410	45000642
22	ROD EYE RBL-6-D	45000633
	CONNECTING SHAFT 160x8	45000634
23	ROSTA SPRING DRS38x60	45000572
24	ROSTA SPRING DRS27x100	XEH09-262-262
25	ROSTA SPRING DRS18x30	45000573
26	ROSTA SPRING DRS18x50	45000574
27	ROSTA SPRING RETAINING BRACKET BR-18	45000575
28	PILLOW BEARING UCP-208	45000635
29	ROLLER BEARING CF12-1-A	45000636
30	POTENTIOMETER	X008-023

# 10. SCHEMATICS

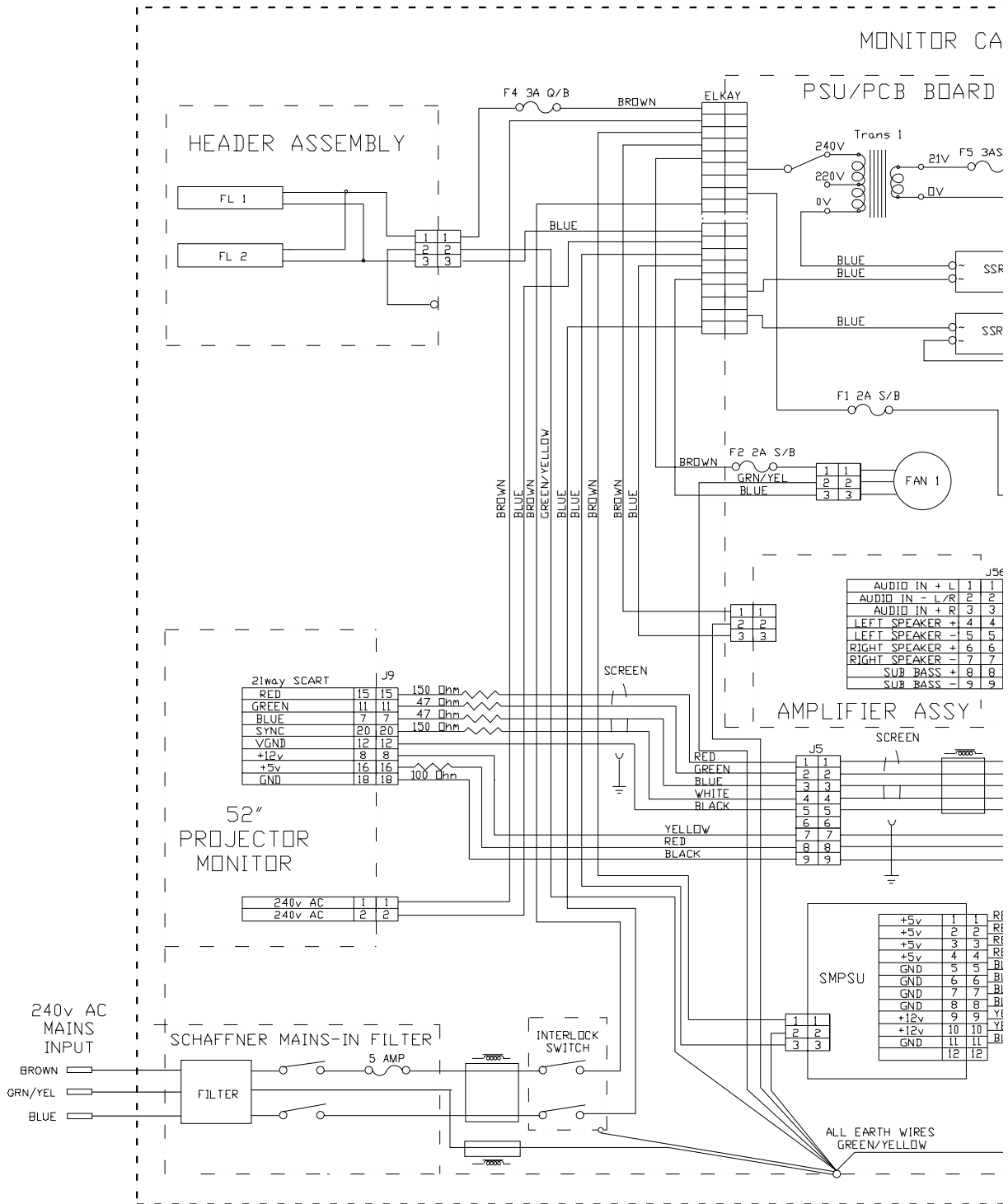

CABINET

ARD ASSEMBLY

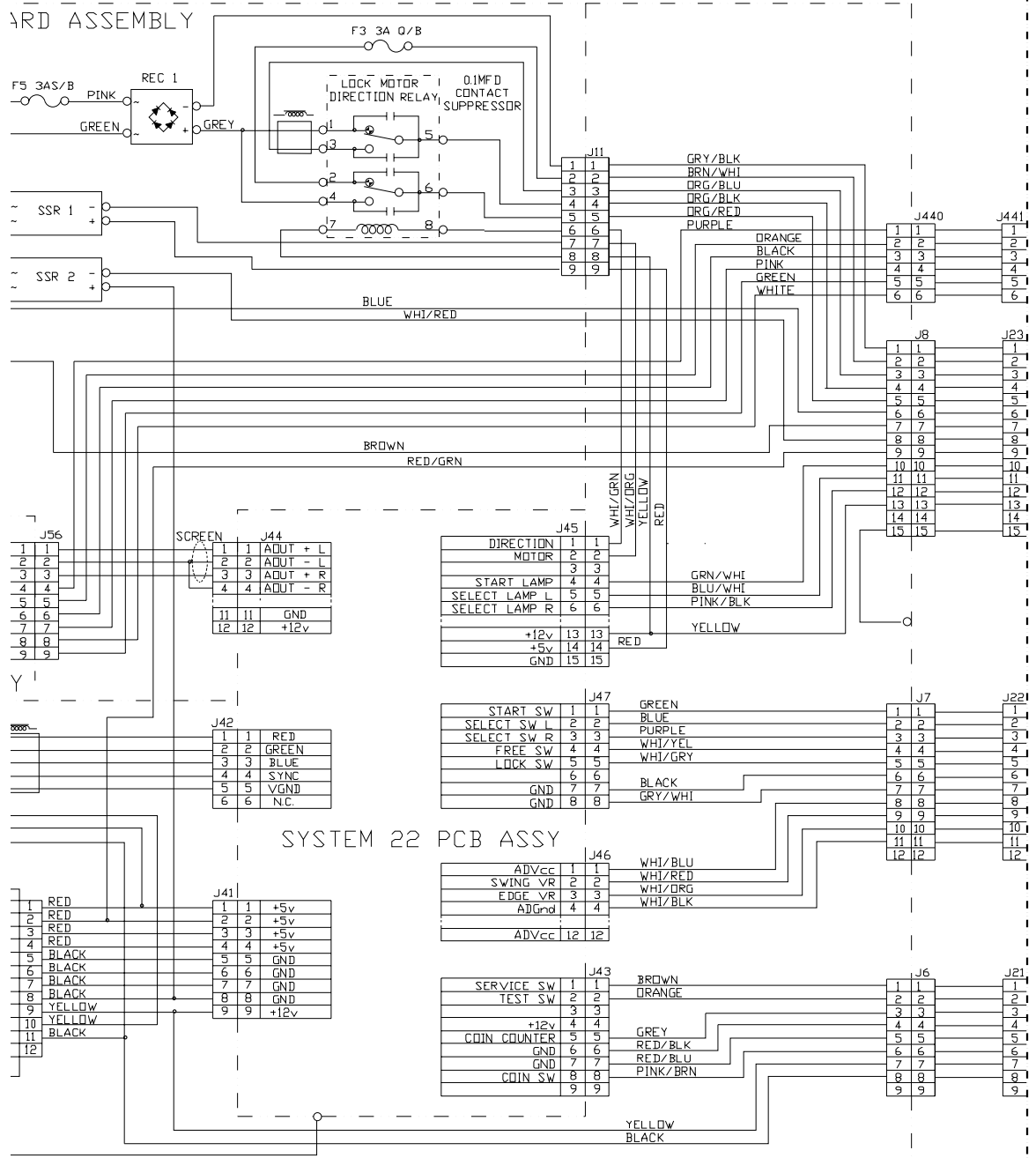

REVISED 26/02/96



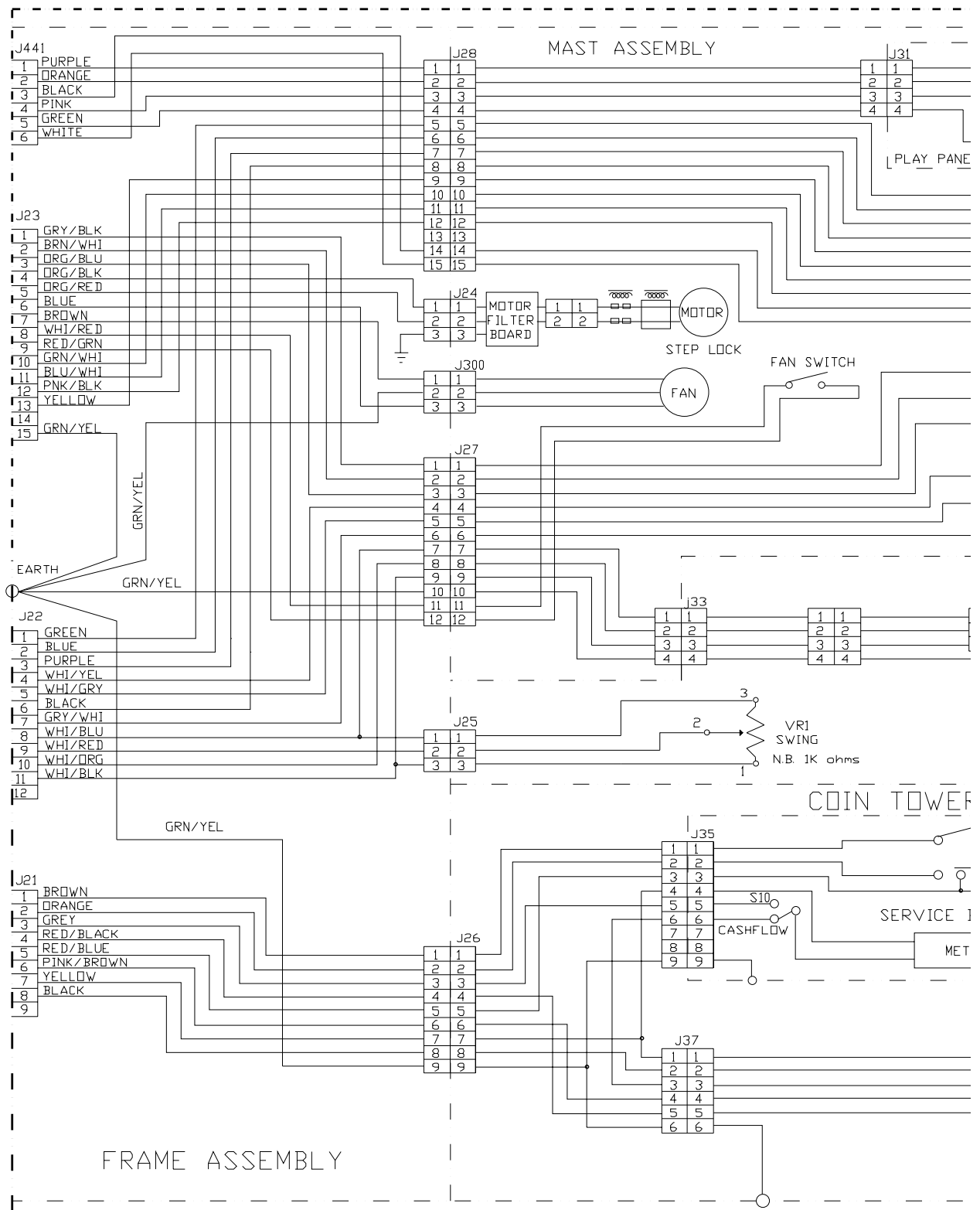

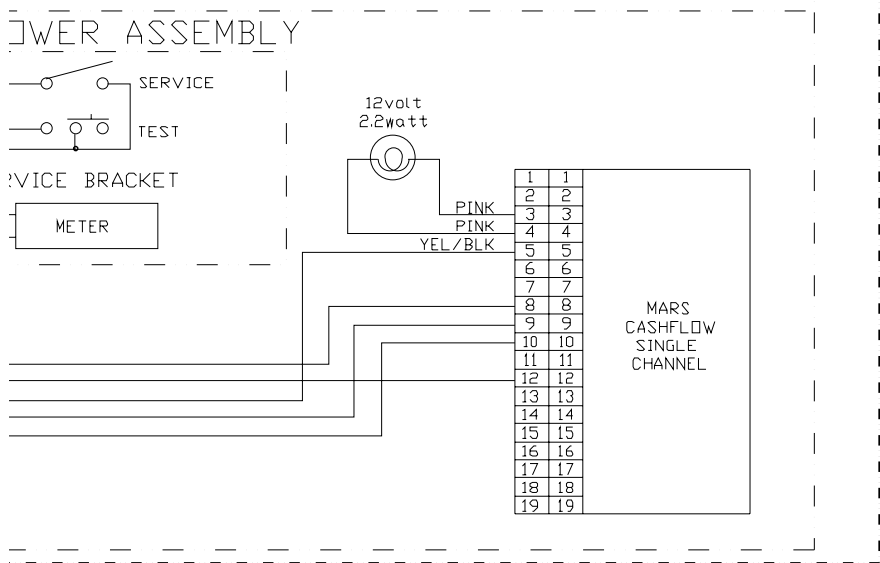
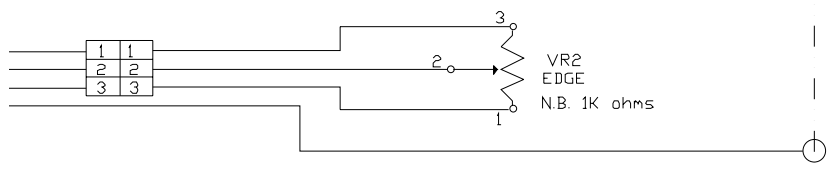
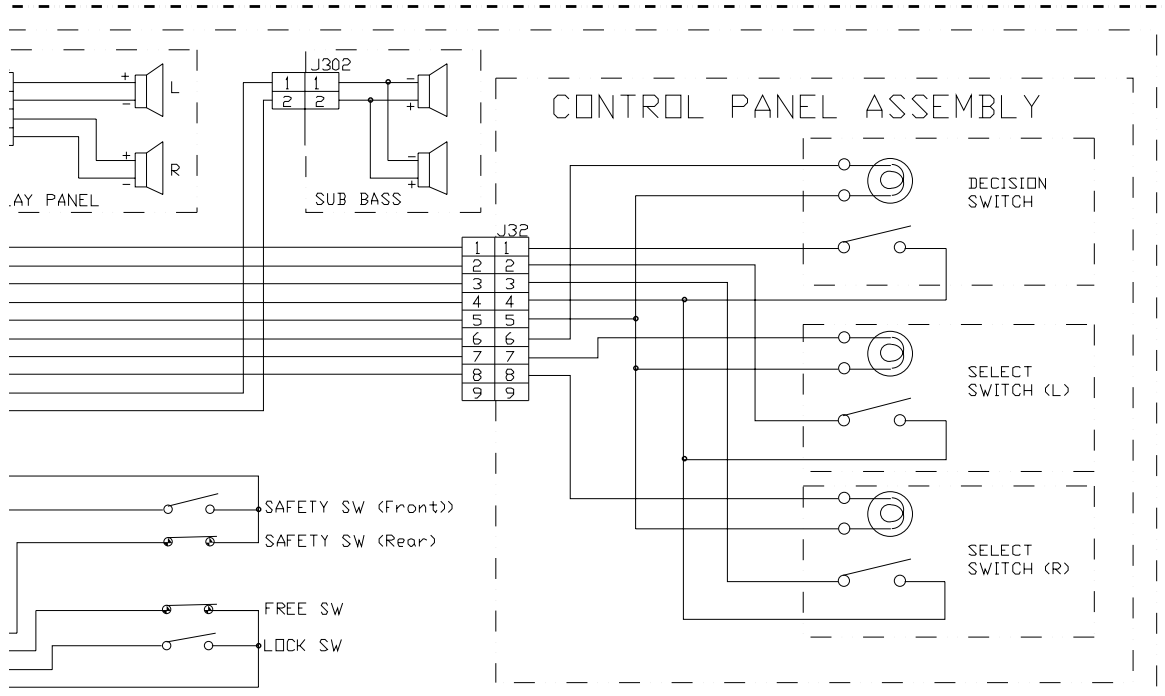

REVISED 26/02/96